

# ULTRA RAPID SEMICONDUCTOR PROTECTION FUSES

## WESTCODE CATALOGUE



## Contents

1.	Introduction	2
2.	Applications & Definitions	2
3.	Fuse Construction & Operation	4
4.	Mounting Precautions for Ultra Rapid Semiconductor Protection Fuses	5
5.	Guide to Westcode part numbering	6
6.	Westcode Range	10
7.	Data sheets	13

## 1. Introduction

Enjoying a reputation as one of the World's leading manufacturers of power semiconductors with its origins in the 1920s, Westcode employs people in the research, development, manufacture and marketing of silicon power products.

This catalogue details the Westcode range of ultra rapid semiconductor protection fuses available for the power electronics industry. Specifically designed to provide protection for power semiconductors against circuit faults and to isolate failed devices.

Utilising proven advanced technology, they provide the performance and characteristics necessary to meet (and exceed) the levels of protection required in the onerous circuit conditions encountered in today and tomorrow's power conversion equipment. Conforming to IEC 269-4 and DIN 57636 (VDE 0636) Part 23 and subject to continuing development to improve performance and reduce volume and weight, a fuse procured through Westcode will be quality assured.

Three key technologies are available.

- "End Contact" - allowing compact assembly and can be directly fastened to bus bars,
- "French & German Standard Blade" - offering 80-110mm diameter fuses in accordance with DIN 43653 that can be mounted into bases or directly on bars, and
- "American Standard" - without base.

All types are equipped with a patented, highly reliable, low voltage trip indicator which does not require the use of an EDV Adaptor. The 4mm stroke trip indicator can operate a microswitch directly screwed onto the fuse. The working voltage of the low voltage trip indicator is 1.5V. In practice, the time required to fully operate the microswitch is 5ms, counted from the end of the semiconductor protection fuse prearcing time.

For further information regarding conformity of our range of ultra rapid semiconductor protection fuses to industry standards, please contact the Westcode Customer Service team on [wsl.sales@westcode.com](mailto:wsl.sales@westcode.com).

## 2. Applications & Definitions

The Westcode range offers fast acting, ultra rapid protection against device rupture, external short circuits, destructive energy let-through and excessive peak currents.

These fuses are produced using proven advanced fuse technology to International standards. The majority of the Westcode range has UL recognition.

Ultra rapid semiconductor protection fuses show two types of rating markings:

- "rated voltage" according to IEC in V RMS for all fuses tested in compliance with IEC (test under rated voltage +10%), and
- "rated voltage" according to American standards, in V RMS for all fuses tested in compliance with US standards (test under the rated voltage).

Commonly used phrases or definitions:

**Ampacity** the current a conductor can carry continuously without exceeding its temperature rating. Ampacity is a function of cable size, insulation type and the conditions of use.

**Ampere Rating** the continuous current carrying capability of a fuse under defined laboratory conditions. The ampere rating is marked on each fuse. Class L fuses and E rated fuses may be loaded to 100% of their ampere rating. For all other fuses, continuous load current should not exceed 80% of fuse ampere rating.

**Available Fault Current** the maximum short circuit current that can flow in an unprotected circuit.

**Bolt-in Fuse** a fuse which is intended to be bolted directly to bus bars, contact pads or fuse blocks.

**Contacts** the external live parts of the fuse that provide continuity between the fuse and the balance of the circuit. Also referred to as ferrules, blades or terminals.

**Co-ordination** the use of overcurrent protective devices which will isolate only that portion of an electrical system which has been overloaded or faulted. See also "Selectivity".

**Current-Limiting Fuses** a fuse which will limit both the magnitude and duration of current flow under short circuit conditions.

**Current-Limiting Range** the available fault currents a fuse will clear in less than ½ cycle, thus limiting the actual magnitude of current flow.

**Dual Element Fuse** often confused with time delay, dual element is a term describing fuse element construction. A fuse having two current responsive elements in series.

**Element** a calibrated conductor inside a fuse that melts when subjected to excessive current. The element is enclosed by the fuse body and may be surrounded by an arc-quenching medium such as silica sand. The element is sometimes referred to as a "link".

**Fault** an accidental condition in which a current path becomes available which by-passes the connected load.

**Fault Current** the amount of current flowing in a faulted circuit.

**Fuse** an overcurrent protective device containing a calibrated current carrying member that melts and opens a circuit under specified overcurrent conditions.

**I<sup>2</sup>t (Ampere Squared Seconds)** a measure of the thermal energy associated with current flow. I<sup>2</sup>t is equal to (I<sub>RMS</sub>)<sup>2</sup> x t, where t is the duration of current flow in seconds.

**Clearing I<sup>2</sup>t** is the total I<sup>2</sup>t passed by a fuse as the fuse clears a fault, with t being equal to the time elapsed from the initiation of the fault to the instant the fault has been cleared.

**Melting I<sup>2</sup>t** is the minimum I<sup>2</sup>t required to melt the fuse element.

**Interrupting Rating (IR)** the maximum current a fuse can safely interrupt. Some special purpose fuses may also have a "Minimum Interrupting Rating". This defines the minimum current that a fuse can safely interrupt.

**Kiloamperes (kA)** 1,000 amperes.

**Limiting or Back-up Fuse** a special purpose fuse which is intended to provide short circuit protection only.

**Overcurrent** any current in excess of conductor ampacity or equipment continuous current rating.

## ULTRA RAPID SEMICONDUCTOR PROTECTION FUSES

**Overload** the operation of conductors or equipment at a current level that will cause damage is allowed to persist.

**Peak Let-Through Current** the maximum instantaneous current passed by a current-limiting fuse when clearing a fault current of specified magnitude.

**Rejection Fuse Block** a fuse block which will only accept fuses of a specific UL class. Rejection is a safety feature intended to prevent the insertion of a fuse with an inadequate voltage or interrupting rating.

**Rejection Fuse** a current-limiting fuse with high interrupting rating and with unique dimensions or mounting provisions.

**Renewable Fuse** a fuse which can be restored for service by the replacement of its element.

**Renewable Element or Link** the field-replacable element of a renewable fuse. Also referred to as a renewal link.

**Selectivity** a main fuse and a branch fuse are said to be selective if the branch fuse will clear all overcurrent conditions before the main fuse opens. Selectivity is desirable because it limits outage to that portion of the circuit which has been overloaded or faulted. Also known as selective co-ordination.

**Semiconductor Fuse** an extremely fast acting fuse intended for the protection of power semiconductors. Sometimes referred to as a rectifier or ultra fast fuse.

**Short Circuit** excessive current flow caused by insulation breakdown or wiring error.

**Threshold Current** the minimum available fault current at which a fuse is current limiting.

**Time Delay Fuse** a fuse which will carry an overcurrent of a specified magnitude for a minimum specified time without opening. The specified current and time requirements are defined in the UL/CSA/NOM 248 fuse standards.

**Voltage Rating** the maximum voltage at which a fuse is designed to operate. Voltage ratings are assumed to be for AC unless specifically labelled as DC.

**High Voltage** - over 34,500V

**Medium Voltage** - 601-34,500V

**Low Voltage** - 600V or less

### 3. Fuse Construction and Operation

A typical fuse consists of an element which is surrounded by a filler and enclosed by the fuse body. The element is welded or soldered to the fuse contacts (blades or ferrules).

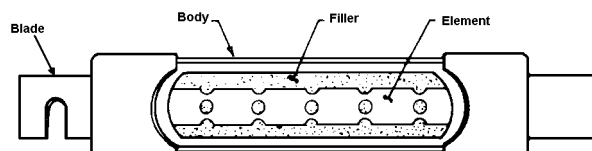

The element is a calibrated conductor. Its configuration, mass and the materials employed are selected to achieve the desired electrical and thermal characteristics. The element provides the current path through the fuse. It generates heat at a rate that is dependent upon its resistance and the load current.

## ***ULTRA RAPID SEMICONDUCTOR PROTECTION FUSES***

The heat generated by the element is absorbed by the filler and passed through the fuse body to the surround air. Filler, such as quartz sand, provides effective heat transfer and allows for the small element cross-section typical in modern fuses. The effective heat transfer allows the fuse to carry harmless overloads. The small element cross-section melts quickly under short circuit conditions. The filler also aids fuse performance by absorbing arc energy when the fuse clears an overload or short circuit.

When a sustained overload occurs, the element will generate heat at a faster rate than the heat can be passed to the filler. If the overload persists, the element will reach its melting point and open. Increasing the applied current will heat the element faster and cause the fuse to open sooner. Thus, fuses have an inverse time current characteristic, i.e. the greater the over current the less time required for the fuse to open the circuit.

This characteristic is desirable because it parallels the characteristics of conductors, motors, transformers and other electrical apparatus. These components can carry low level overloads for relatively long times without damage. However, under high current conditions damage can occur quickly. Because of its inverse time current characteristic, a properly applied fuse can provide effective protection over a broad current range, from low level overloads to high level short circuits.

### **4. Mounting Precautions for Ultra Rapid Semiconductor Protection Fuses**

Screws can be used, however, the best solution remains our studs which allow to fully use the threads in terminals and to balance the recommended tightening torque. Paralleling of end contact types has to be done by using "laminated" on one side because of the tolerance of their length. Blade types; the fuse must not be used to balance tightening torque. The fastening of fuse between two bars can be done upon the condition that they are in the same plane at less than 2mm, see figure below.

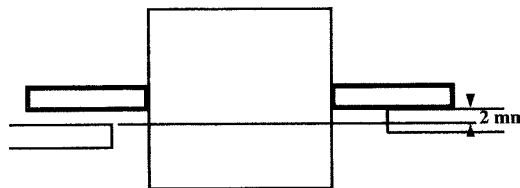

**5. Guide to Part Numbering for Square Bodied Semiconductor Fuses.**

The part numbers for this range are built up of 12 digits, all of which convey a piece of information about the fuse, example **069UR3D0800B**

<b>1</b>	<b>2</b>	<b>3</b>	<b>4</b>	<b>5</b>	<b>6</b>	<b>7</b>	<b>8</b>	<b>9</b>	<b>10</b>	<b>11</b>	<b>12</b>
0	6	9	U	R	3	D	0	8	0	0	B
Rated voltage			Type & Standard		Size	Fixing dimension	rms current rating			Indicator Type	

**Rated voltages (Digits 1-3)**

- 050 = 500V
- 060 = 600V
- 066 = 660V
- 069 = 690V
- 070 = 700V
- 100 = 1000V
- 110 = 1100V
- 120 = 1200V
- 125 = 1250V
- 130 = 1300V

**Type & Standard (Digits 4 & 5)**

- NH = NH German standard, knife blade contacts
- NS = NH German standard, slotted knife blade contacts
- NR = NH German standard, knife blade contacts, gR characteristics
- GD = DIN 43 653, German standard DIN80, non-silicated
- GG = DIN 43 653, German standard DIN80, gR characteristics
- GQ = DIN 43 653, German standard DIN80, silicated
- GS = DIN 43 653, German standard DIN80, gR characteristics, microswitch capable
- GT = DIN 43 653, German standard DIN80, gR characteristics, microswitch capable, non silicated
- GU = DIN 43 653, German standard DIN80, gR characteristics, microswitch capable, silicated
- UR = DIN 43 653, German/French dimensions, large square body
- UG = DIN 43 653, German/French dimensions, large square body, gR characteristics
- US = DIN 43 653 US dimensions, large square body
- UF = French standard blades
- FR = Adapted ferrule fuse, gR characteristics

**Body Size (Digit 6)**

- C = 000
- D = 00
- 0 = 0
- 1 = 1
- 2 = 2
- 3 = 3
- 4 = 44
- 5 = 84
- E = 17mm diameter

**Fixing Dimensions (Digit 7)**

A = 80mm  
B = 90mm  
C = 100mm  
D = 110mm  
E = 125mm  
J = 210mm  
L = 70mm  
K = Knife Blade  
S = Stud/Threaded hole, metric thread  
U = Stud/Threaded hole, imperial thread  
T = Dual Threaded hole, metric thread  
V = Press-Pack

Note: These dimensions are approximate and may cover a fixing centre close to the nominal figure given.

**Current Ratings (Digits 8-11)**

Current rating of the fuse is represented by the numeric value of the rating preceded by zeros to make up 4 digits, e.g.

0010 = 10A  
0100 = 100A  
1000 = 100A

**Indicator Type (Digit 12)**

N = None fitted  
B = Button type  
F = Flap type  
I = Trip indicator  
C = Button indicator plus adaptor  
H = Flap indicator with microswitch lug

Thus, the example above 069UR3D0800B is; 690V, DIN 43 653 German/French dimensions, large square body, Size 3, with 110mm fixing 800A with button indicator.



**ULTRA RAPID SEMICONDUCTOR PROTECTION FUSES**

**Guide to Part Numbering for Ferrule Semiconductor Fuses**

The part numbers for this range are built up of 9 digits, all of which convey a piece of information about the fuse, example **F070B030S**

1	2	3	4	5	6	7	8	9
F	0	7	0	B	0	3	0	S
Type	Rated ac voltage			Dimensions	rms current rating		Indicator type	

**Type (Digit 1)**

F = Ferrule

**Rated voltage (Digits 2-4)**

050 = 500V

060 = 600V

070 = 700V

**Dimensions (Digit 5)**

A = 10mm diameter x 38mm

B = 14mm diameter x 51mm

C = 22mm diameter x 57mm

**Rms Current rating (Digits 6-8)**

Signify the rms current rating of the fuse with leading zeros to make up 3 digits.

001 = 1A

010 = 10A

100 = 100A

**Indicator type (Digit 9)**

N = none fitted

S = striker pin type

Thus the above example, F070B030S is a Ferrule type, 700V, 14x51mm, 30amp fuse with striker pin indicator.

**ULTRA RAPID SEMICONDUCTOR PROTECTION FUSES**

**Guide to Part Numbering for British Style Semiconductor Fuses.**

This part numbering system consists of the current rating followed by 2,3,or 4 digits giving the fuse rms voltage rating and body size, example: **315MW**

1	2	3	4	5	6	7	8
3	1	5	M	W			
Current Rating			Fuse type			Indicator	

**Current Rating (Digits 1-3)**

001 = 1A  
010 = 10A  
100 = 100A

**Types (Digits 4-7)**

250V types      LCW = 8.4mm body diameter  
                      LEW = 17.5mm body diameter  
                      LMW = 35mm body diameter  
                      LMMW = 35mm body diameter, twin body

690V types      CW = 8.4mm body diameter  
                      EW = 17.5mm body diameter  
                      EWF = 17.5mm body diameter  
                      MW = 35mm body diameter  
                      MMW = 35mm body diameter, twin body

**Indicator (last digit)**

I = trip indicator mounted to fuse

Thus, in the above example, 315MW is a 315Amp 690V 35mm body diameter British Standard fuse without trip indicator.

**6. The Westcode Range**

**6.1 American Standard, Square Body**

450-700V End Contact	070USxUxxxxB
650-1300V End Contact	130USxUxxxxB
500-700V Blade Contact (short)	070USxBxxxxB
500-700V Blade Contact (long)	070USxDxxxxB
650-1300V Blade Contact (long)	130USxDxxxxB

**6.2 British Standard, BS88 Round Body**

250V – 10x28mm & 17x27mm diameter	xxLCW, xxxLEW/I
250V – 36x55 & 2x36x55mm diameter	xxxMW/I, xxxMMW/I
660V – 36x27mm & 2x36x27mm diameter	xxxLMW/I, xxxLMMW/I
660V – 10x51mm & 2x17x49mm diameter	xxCW, xxxEEW/I
690V – 17x49mm diameter	xxxEW/I
660V – Size 000 aR	070BQCLxxxxN/I

**6.3 French Standard, European Square Body**

450-690V End Contact	069URxSxxxxB
650-1250V End Contact	125URxSxxxxB
690V Standard Blade Contact	069UFxAxxxxB & 069UFxBxxxxB

**6.4 Ferrule Style**

660-700V, 1-32A, 10x38mm	F070AxxxN
700V, 1-50A, 14x51mm	F070BxxxN/S
690V, 20-100A, 22x58mm	F070CxxxN/S

**6.5 German Standard, European Square Body**

600-690V DIN 80 Blade Contact	069URxAxxxxB
600-690V DIN 110 Blade Contact	069URxDxxxxB
900-1250V Din 110 Blade Contact	125URxDxxxxB
690V DIN 80 – aR Size 00	069GSDAxxxxF
690V DIN 80 – gR Size 00	069GUDAxxxxF
500-700V DIN 80 – aR Size 000	070GQCAxxxxF/N & 070GTCAxxxxF (Trip Tag)
690V DIN 80 – gR Size 000	070GGCAxxxxF/N & 070GSCAxxxxF (Trip Tag)
660-690V Knife Blade – gR Sizes 00 & 000	069NRxKxxxxF
660-690V Knife Blade – aR 000, 00, 0, 1, 2 & 3	069NHxKxxxxF

**6.6 Microswitch Systems**

MS 3V 1-5	Sizes 0, 1, 2, 3
MS 7V 1-5	Sizes 0, 1, 2, 3
MS 4L 2-5 B2 or B6 +PRES	DIN Size 000 & 00
MC 6,3 GR 2-5N	BS88-4 Trip Indicator
MC 3E 1-5N	BS88-4 Trip Indicator

**6.7 Fuse Holders**

SI 000 DIN80  
SI 00 DIN80  
SI DIN80 630A & 1250A  
SI DIN110 630A & 1250A  
SI TT 30/31  
SI TT 70/71  
SI TT 32/33  
SI TT 72/73

Size 000 & 00 DIN80 Con. Fuses  
Size 000 & 00 DIN80 Con. Fuses  
Size 0,1,2, & 3 DIN80 Blade Con. Fuses  
Size 0,1,2, & 3 DIN110 Blade Con. Fuses  
Size 0,1,2, & 3 End Con. Fuses  
Size 0,1,2, & 3 End Con. Fuses  
Size 0,1,2, & 3 End Con. Fuses  
Size 0,1,2, & 3 End Con. Fuses

**6.8 Adaptors**

EDV Size 3



EDV Size 7



7. Data sheets

# DATA SHEETS

## Ultra Rapid Semiconductor Protection Fuse American Square Body Type Fuses













**American End Contacts  
Voltage Ratings 450V to 700V  
Current Ratings 63A to 2500A  
Sizes 0, 1, 2, 3**













### **Key Features:**

- ❖ 690V voltage rating complying with IEC, DIN and VDE standards
- ❖ Exceptionally low  $I^2t$ , power losses
- ❖ Non Magnetic construction, highly reliable low voltage indicator system
- ❖ Conform to UL, IEC, DIN and VDE standards
- ❖ Increased technical performance give higher ratings and a reduction in volume and weight
- ❖ All models with integrated trip-indicator
- ❖ Microswitch system reference MS 3V 1-5









Main Characteristics:

Size	Voltage U <sub>N</sub> (V)	Ref:		Current rating I <sub>N</sub> (A)	Pre-arcing I <sup>2</sup> t @ 1 ms I <sup>2</sup> t <sub>p</sub> (kA <sup>2</sup> s)	Total Clearing I <sup>2</sup> t @ U <sub>N</sub> (kA <sup>2</sup> s)	Watt Losses		Tested Interrupting rating
							0.8I <sub>N</sub>	I <sub>N</sub>	
0	700V	070US0U0063B		63	0.20	1.10	7.5	14	170kA / 700V
		070US0U0080B		80	0.33	1.8	9.5	19	
		070US0U0100B		100	0.47	2.5	13	26	
		070US0U0125B		125	0.85	4.5	15	30	
		070US0U0160B		160	1.6	8.5	18.5	37	
		070US0U0200B		200	3	15.5	21.5	42	
		070US0U0250B		250	5.8	30	25	48	
		070US0U0315B		315	12	62	22.5	53	
		070US0U0350B		350	15.5	80	30	57	
		070US0U0400B		400	23	120	32.5	60	
		070US0U0450B		450	26	150	44	80	
		070US0U0500B		500	41	240	44	80	
		070US0U0550B	-	550	52	300	45	80	











Notes: Minimum operating voltage for integrated trip indicator = 20V. Micro switch reference: MS 3V 1-5  
 Shaded data; not included on curves, refer to factory.

Size	Voltage U <sub>N</sub> (V)	Ref:		Current rating I <sub>N</sub> (A)	Pre-arcing I <sup>2</sup> t @ 1 ms I <sup>2</sup> t <sub>p</sub> (kA <sup>2</sup> s)	Total Clearing I <sup>2</sup> t @ U <sub>N</sub> (kA <sup>2</sup> s)	Watt Losses		Tested Interrupting rating
							0.8I <sub>N</sub>	I <sub>N</sub>	
1	700V	070US1U0200B		200	2.60	13.50	22.5	45	170kA / 700V
		070US1U0250B		250	4.70	25.00	25.5	52	
		070US1U0315B		315	7.50	40.00	32.5	65	
		070US1U0350B		350	10.50	55.00	33.5	67	
		070US1U0400B		400	19.00	100.00	34.0	68	
		070US1U0450B		450	26.50	140.00	35.0	70	
		070US1U0500B		500	37.00	195.00	36.0	70	
		070US1U0550B		550	52.00	280.00	37.5	70	
		070US1U0630B		630	75.00	390.00	42.5	75	
		070US1U0700B		700	95.00	490.00	42.5	85	
		070US1U0800B		800	140.00	800.00	60.0	105	

Notes: Minimum operating voltage for integrated trip indicator = 20V. Micro switch reference: MS 3V 1-5  
 Shaded data; not included on curves, refer to factory.

Size	Voltage $U_N$ (V)	Ref:		Current rating $I_N$ (A)	Pre-arcing $I^2t @ 1 \text{ ms}$ $I^2_{tp}$ (kA <sup>2</sup> s)	Total Clearing $I^2t @ U_N$ (kA <sup>2</sup> s)	Watt Losses		Tested Interrupting rating
							$0.8I_N$	$I_N$	
2	700V	070US2U0400B		400	15	80	32.5	75	170 kA / 700V
		070US2U0450B		450	20	115	40	80	
		070US2U0500B		500	28	145	45	90	
		070US2U0550B		550	37	195	47.5	95	
		070US2U0630B		630	54	280	52.5	105	
		070US2U0700B		700	76	400	55	110	
		070US2U0800B		800	115	600	60	120	
	690V +6%	070US2U0900B		900	170	900	62.5	125	200 kA / 700V
		070US2U1000B		1000	240	1250	67.5	135	
	650V	065US2U1100B		1100	270	1670		165	160kA @ 650V
	600V	060US2U1250B		1250	410	2400		180	150kA @ 600V
	550V	055US2U1400B		1400	555	3400		190	130kA @ 550V
		055US2U1600B		1600	870	5300		195	
500V	050US2U1800B		1800	1050	8700		230	110kA @ 500V	

Notes: Minimum operating voltage for integrated trip indicator = 20V. Micro switch reference: MS 3V 1-5  
 Shaded data; not included on curves, refer to factory.

Size	Voltage $U_N$ (V)	Ref:		Current rating $I_N$ (A)	Pre-arcing $I^2t @ 1 \text{ ms}$ $I^2_{tp}$ (kA <sup>2</sup> s)	Total Clearing $I^2t @ U_N$ (kA <sup>2</sup> s)	Watt Losses		Tested Interrupting rating
							$0.8I_N$	$I_N$	
3	700V	070US3U0500B		500	19	100	52.5	105	170 kA / 700V
		070US3U0550B		550	27	140	55	105	
		070US3U0630B		630	40	210	60	110	
		070US3U0700B		700	55	300	62.5	115	
		070US3U0800B		800	95	490	65	120	
		070US3U0900B		900	135	700	67.5	120	
		070US3U1000B		1000	170	900	77.5	135	
		070US3U1100B		1100	240	1260	80	135	
	690V +6%	070US3U1250B		1250	350	1850	90	150	200 kA / 700V
		070US3U1400B		1400	480	2400	100	160	
	650V	065US3U1600B	-	1600	555	2900	120	210	160kA @ 650V
		065US3U1800B		1800	720	3870	-	225	
	600V	060US3U2000B		2000	950	4800	-	250	150kA @ 600V
	550V	055US3U2250B		2250	1250	5160	-	280	130kA @ 550V
	500V	050US3U2500B		2500	1870	6540	-	280	110kA @ 500V

Notes: Minimum operating voltage for integrated trip indicator = 20V. Micro switch reference: MS 3V 1-5  
 Shaded data; not included on curves, refer to factory.

**Electrical Characteristics:**

**Times vs current characteristics**

The curves shown on page 4 indicate the pre-arcing time for each rated current as a function of RMS value of pre-arcing current I:

- Tolerances on this current  $\pm 8\%$
- Beyond 30 sec or 10 sec, small overloads must be eliminated by another device.



Curve CC' represents the maximum times taken by the associated device to clear small overloads; only its horizontal line is represented.

Its oblique line must be plotted according to sketch in top right corner:

- The intersection of the fuse and CC' curves indicates the minimum breaking current  $I_{pm}$  of the fuse.

Size 0

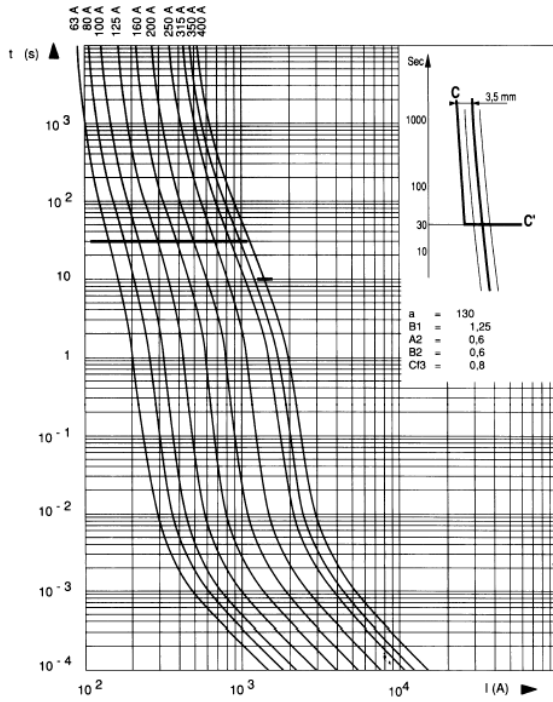

Size 1

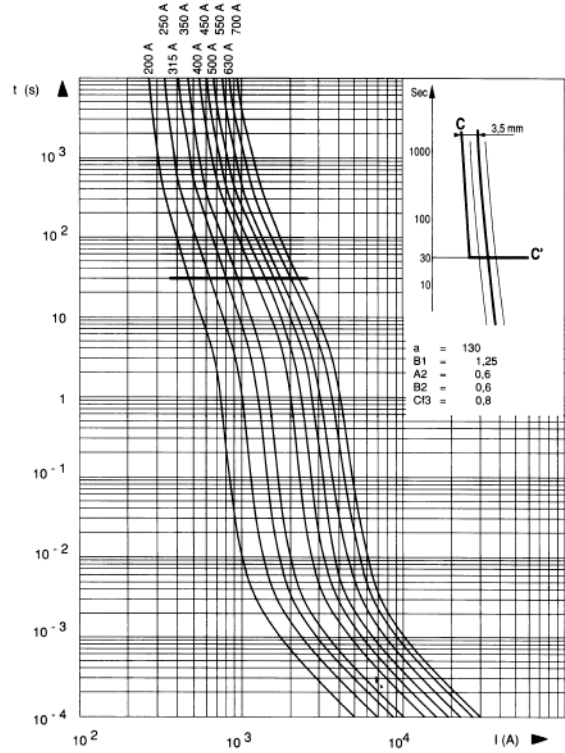

Size 2

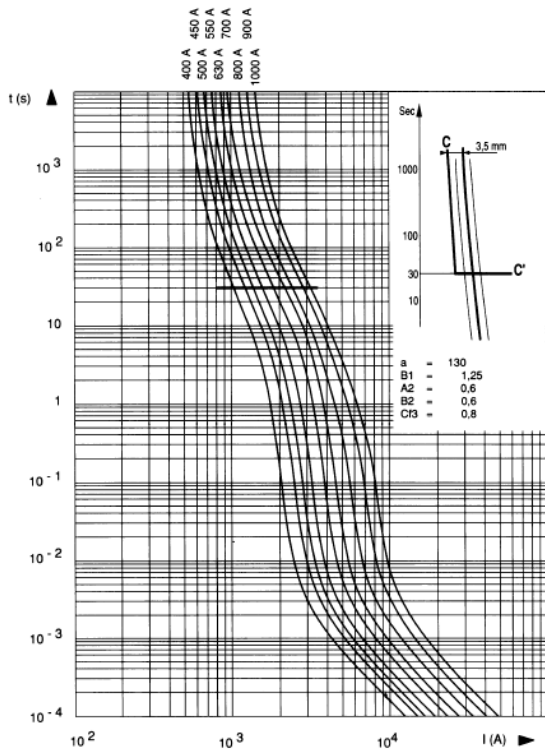

Size 3

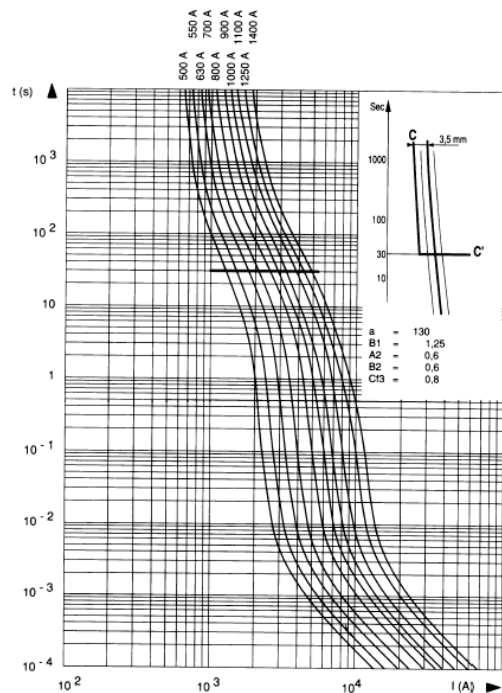

**Total clearing I<sup>2</sup>T:**

The horizontal curves given below indicated the maximum values of total operating I<sup>2</sup>t (I<sup>2</sup>t<sub>t</sub>) as a function of prospective current I<sub>p</sub> @ 660V, cosφ = 0.15. Oblique lines indicate the corresponding total operating time T<sub>t</sub>, with pre-arcing time in brackets.

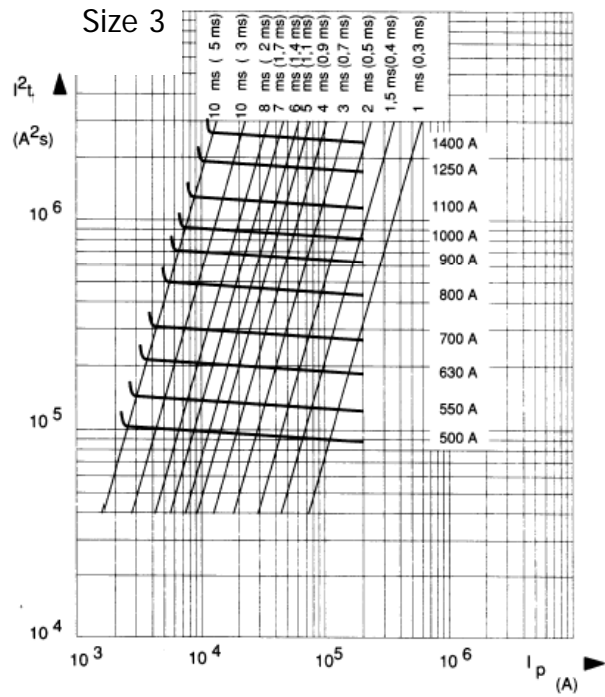
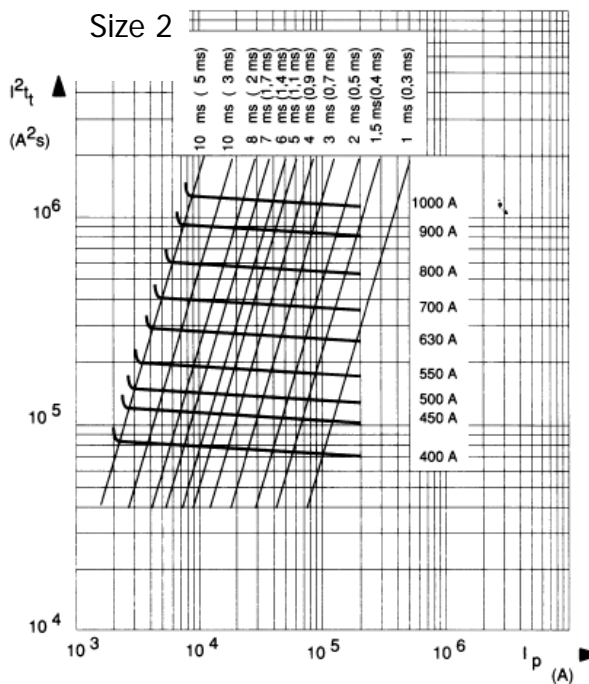
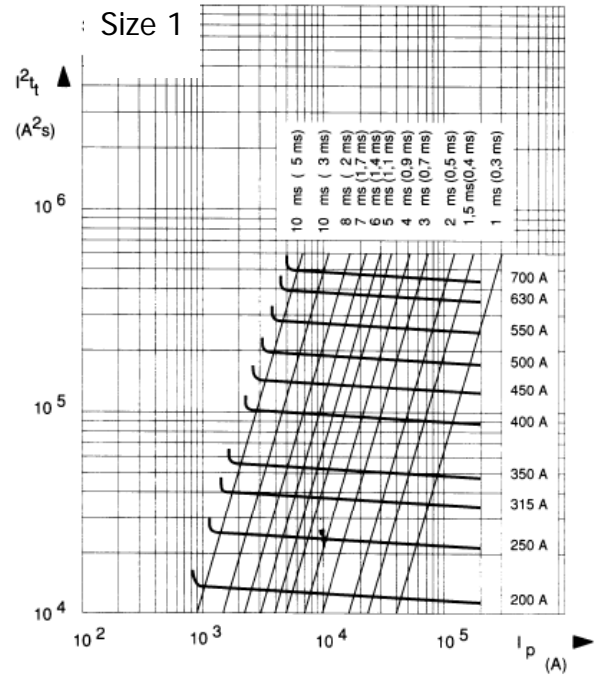
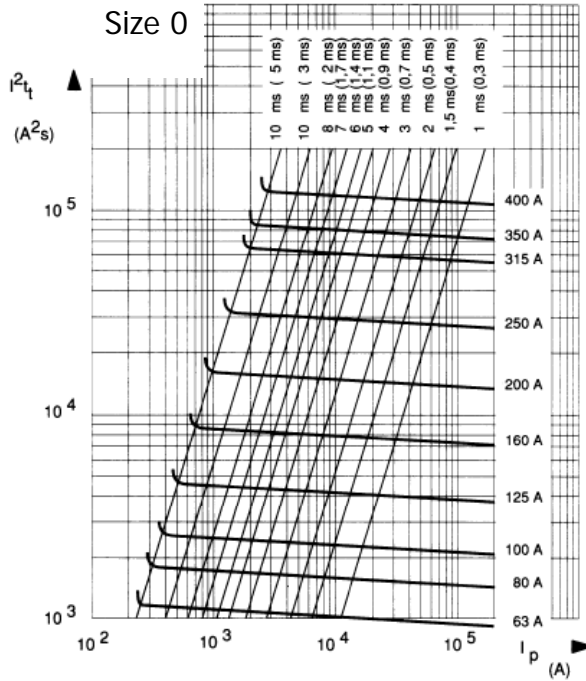

**Cut off Characteristics:**

The curves below indicate, for each rated current, the peak value  $I_c$  that the current may reach as a function of the prospective fault current  $I_p$ .

Size 0

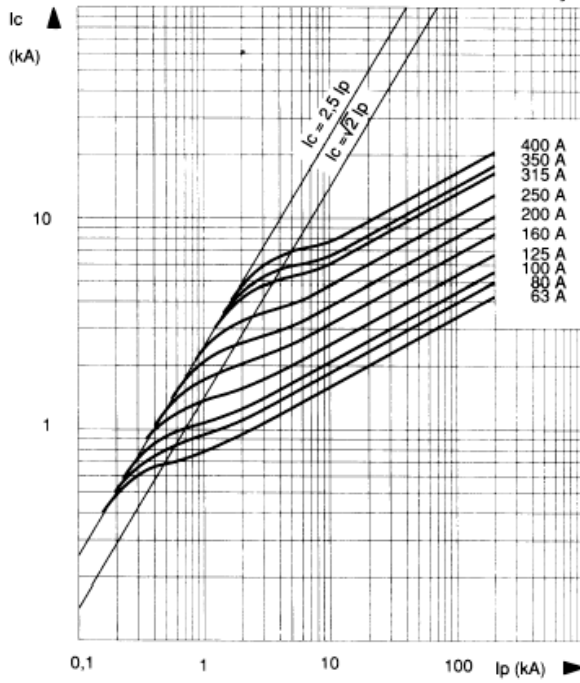

Size 1

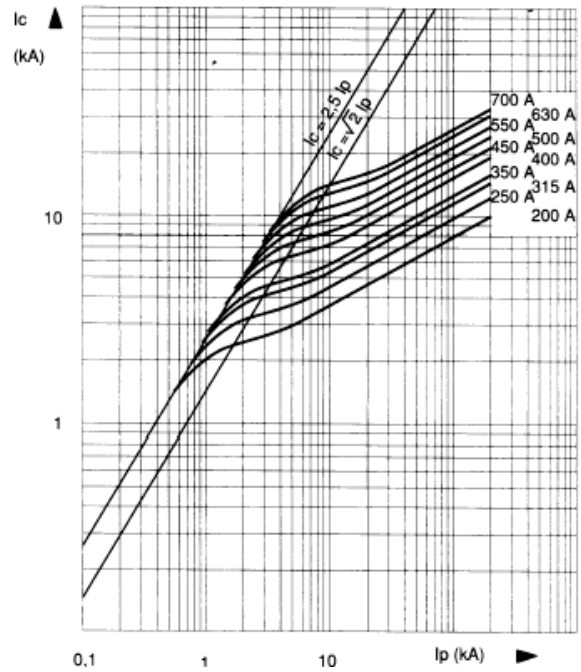

Size 2

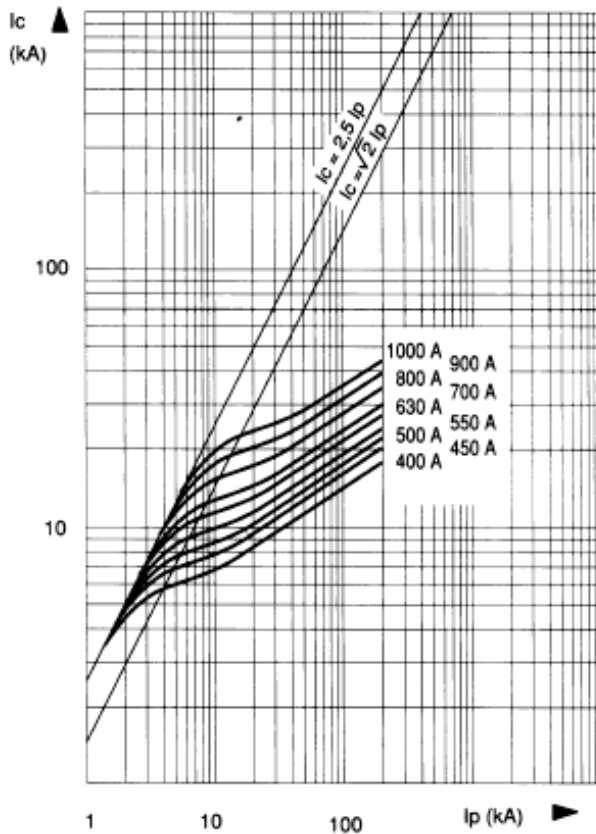

Size 3

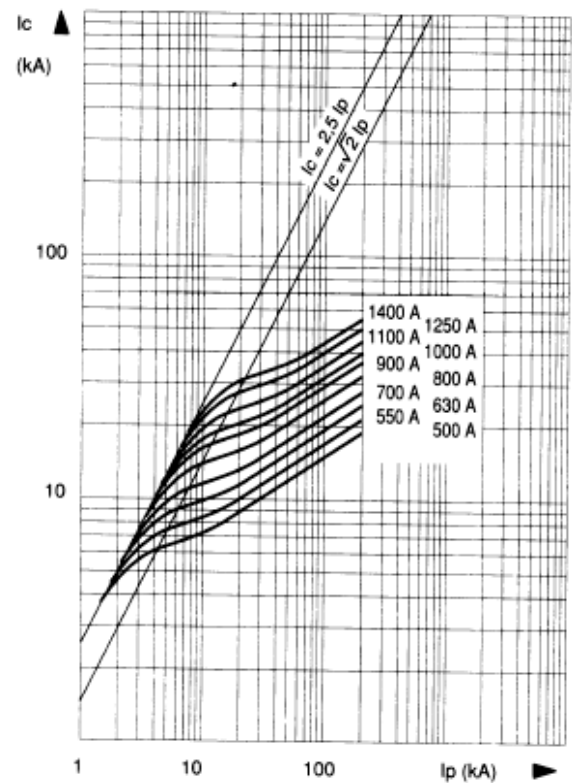

**Corrective Factor – Peak Arc Voltage:**

**$I^2t$  Multiplier Coefficient**

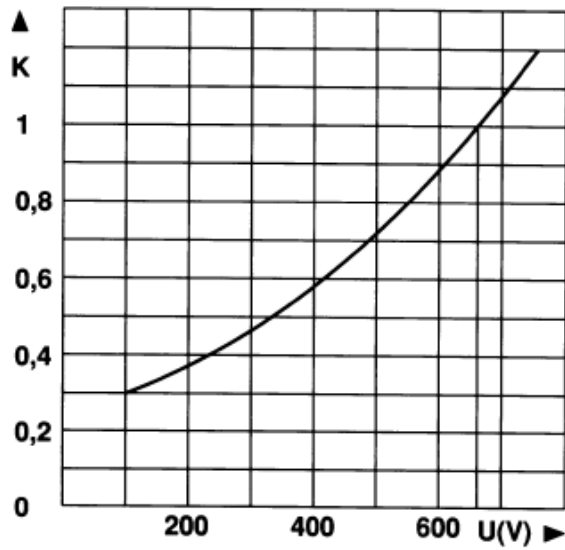

The above Mean curve shows variation of total clearing time ( $I^2t_i$ ) and total operating time  $T_i$  in accordance with working voltage U.

**Peak Arc Voltage**

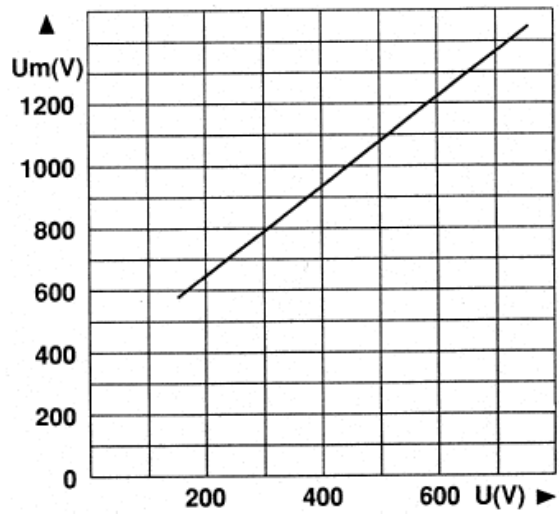

Curve indicating peak arc voltage  $U_m$  which may appear across fuse terminals as a function of working voltage U @  $\cos \varphi = 0.15$ .

**Dissipated Power**

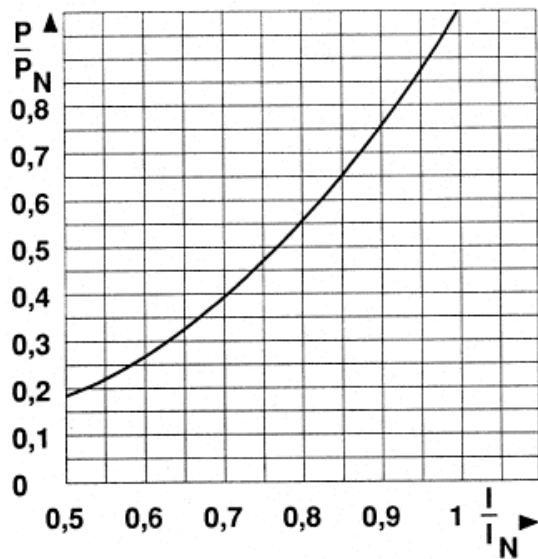

Curve enabling calculation of dissipated power P by a fuse rated  $I_N$ , as a function of the RMS current I, in multiples of  $I_N$  in a steady state.

**Outline Drawing & Ordering Information:**

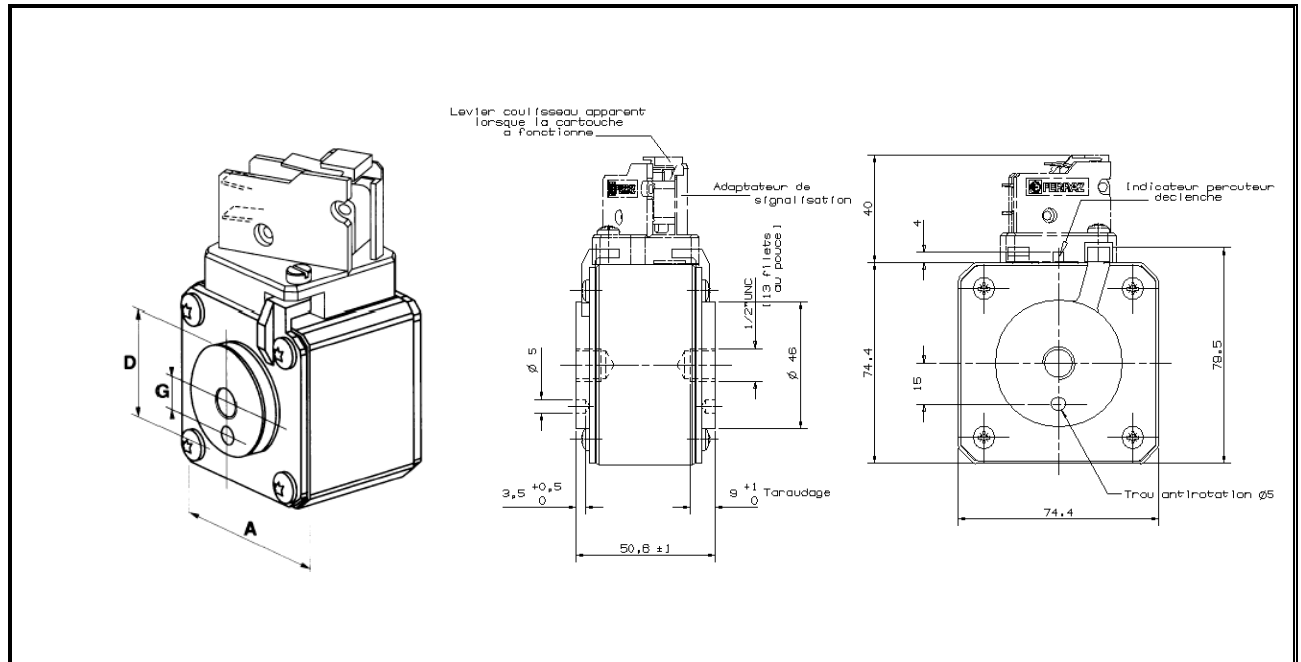

Dimensions (mm)									
Size	A	B	C	D	E	d Imperial	G	p	Weight
0	40	46.5	82	26	50.6	5/16-18"	9	6	245g
1	51	56.5	91	30	50.6	5/16-18"	9	9	370g
2	60	65.5	100	38 / 42*	50.6	3/8-16"	15	9	510g / 600g
3	74.5	79.5	114	46 / 52*	50.6	1/2-13"	15	9	790g / 910g

\*size 2 from 900A and size 3 from 1250A

ORDERING INFORMATION (Please quote code as below)					
Voltage Rating (V)	Type	Size	Fixing	Current Rating Amps	Indicator Type
700	US	0, 1, 2, or 3	U	0063 – 1600	B

Order code: eg. **070US3U0063B** = 700V, American Square Body Fuse with end contacts, Size 3, imperial thread, 63A with button indicator

**IXYS Semiconductor GmbH**  
 Edisonstraße 15  
 D-68623 Lampertheim  
 Tel: +49 6206 503-0  
 Fax: +49 6206 503-627  
 E-mail: [marcom@ixys.de](mailto:marcom@ixys.de)



**Westcode Semiconductors Ltd**  
 Langley Park Way Langley Park  
 Chippenham Wiltshire SN15 1GE  
 Tel: +44 (0)1249 444524  
 Fax: +44 (0)1249 659448  
 E-mail: [WSL.sales@westcode.com](mailto:WSL.sales@westcode.com)

**IXYS Corporation**  
 3540 Bassett Street  
 Santa Clara CA 95054 USA  
 Tel: +1 (408) 982 0700  
 Fax: +1 (408) 496 0670  
 E-mail: [sales@ixys.com](mailto:sales@ixys.com)

[www.westcode.com](http://www.westcode.com)

[www.ixys.com](http://www.ixys.com)

**Westcode Semiconductors Inc**  
 3270 Cherry Avenue  
 Long Beach CA 90807 USA  
 Tel: +1 (562) 595 6971  
 Fax: +1 (562) 595 8182  
 E-mail: [WSI.sales@westcode.com](mailto:WSI.sales@westcode.com)

The information contained herein is confidential and is protected by Copyright. The information may not be used or disclosed except with the written permission of and in the manner permitted by the proprietors Westcode Semiconductors Ltd.

© Westcode Semiconductors Ltd.

In the interest of product improvement, Westcode reserves the right to change specifications at any time without prior notice.

## Ultra Rapid Semiconductor Protection Fuse American Square Body Type Fuses



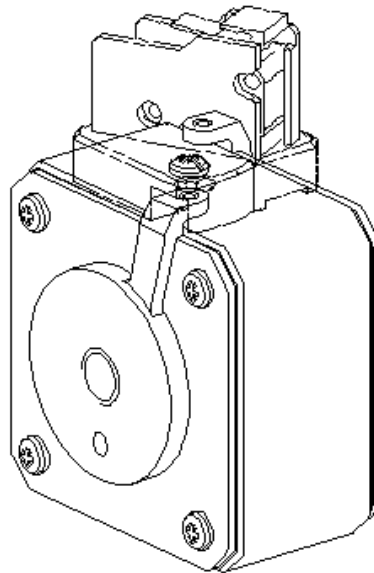







American End Contacts  
Voltage Ratings 650V to 1300V  
Current Ratings 63A to 1800A  
Sizes 0, 1, 2, 3













### Key Features:

- ❖ Exceptionally low  $I^2t$ , power losses
- ❖ Highly reliable low voltage indicator system
- ❖ Non Magnetic construction
- ❖ Conform to UL, CSA investigated, IEC, DIN and VDE standards
- ❖ Increased technical performance gives higher ratings and a reduction in volume and weight
- ❖ Microswitch system reference MS 7V 1-5











**Main Characteristics:**

Size	Voltage U <sub>N</sub> (V)	Ref:		Current rating I <sub>N</sub> (A)	Pre-arcing I <sup>2</sup> t @ 1 ms I <sup>2</sup> t <sub>p</sub> (kA <sup>2</sup> s)	Total Clearing I <sup>2</sup> t @ U <sub>N</sub> (kA <sup>2</sup> s)	Watt Losses 0.8I <sub>N</sub> I <sub>N</sub>		Tested Interrupting rating
0	1300V	130US0U0063B		63	0.21	1.2	13	26	100kA @ 1300V
		130US0U0080B		80	0.47	2.7	13.5	27	
		130US0U0100B		100	0.83	4.8	15	30	
		130US0U0125B		125	1.3	7.5	19	38	
		130US0U0160B		160	2.55	15	22.5	45	
		130US0U0200B		200	4.7	27	27	54	
		130US0U0250B		250	9.6	55	29	58	
		130US0U0280B		280	14	82	30.5	61	
		130US0U0315B		315	20	115	33	66	
	1200V	120US0U0350B		350	28	160	34	68	150kA @ 1200V













Notes: Minimum operating voltage for integrated trip indicator = 20V Microswitch reference : MS 7V 1-5

Size	Voltage U <sub>N</sub> (V)	Ref:		Current rating I <sub>N</sub> (A)	Pre-arcing I <sup>2</sup> t @ 1 ms I <sup>2</sup> t <sub>p</sub> (kA <sup>2</sup> s)	Total Clearing I <sup>2</sup> t @ U <sub>N</sub> (kA <sup>2</sup> s)	Watt Losses 0.8I <sub>N</sub> I <sub>N</sub>		Tested Interrupting rating
1	1300V	130US1U0160B		160	2.6	15	23	46	100kA @ 1300V
		130US1U0200B		200	4.7	27	27	54	
		130US1U0250B		250	8.9	51	30.5	61	
		130US1U0280B		280	12	68	34	68	
		130US1U0315B		315	16	92	36.5	73	
		130US1U0350B		350	22	127	38	76	
		130US1U0400B		400	38	220	38	76	
		130US1U0450B		450	47	270	43.5	87	
		130US1U0500B		500	68	390	45	90	
		1200V	120US1U0550B		550	84	485	49	98
		120US1U0630B		630	125	725	52.5	105	

Notes: Minimum operating voltage for integrated trip indicator = 20V Micro switch reference : MS 7V 1-5

Size	Voltage U <sub>N</sub> (V)	Ref:		Current rating I <sub>N</sub> (A)	Pre-arcing I <sup>2</sup> t @ 1 ms I <sup>2</sup> t <sub>p</sub> (kA <sup>2</sup> s)	Total Clearing I <sup>2</sup> t @ U <sub>N</sub> (kA <sup>2</sup> s)	Watt Losses 0.8I <sub>N</sub> I <sub>N</sub>		Tested Interrupting rating
2	1300V	130US2U0280B		280	10	60	36	72	125kA @ 1300V
		130US2U0315B		315	15	87	38	76	
		130US2U0350B		350	21	120	38.5	77	
		130US2U0400B		400	32.5	190	40	80	
		130US2U0450B		450	44	255	46.5	87	
		130US2U0500B		500	57	330	47	94	
		130US2U0550B		550	68	390	55	110	
		130US2U0630B		630	105	610	56.5	113	
		1200V	120US2U0700B		700	145	815	61	122
		120US2U0800B		800	215	1240	62.5	125	

Notes: Minimum operating voltage for integrated trip indicator = 20V  
Microswitch reference : MS 7V 1-5

Size	Voltage U <sub>N</sub> (V)	Ref:		Current rating I <sub>N</sub> (A)	Pre-arcing I <sup>2</sup> t @ 1 ms I <sup>2</sup> t <sub>p</sub> (kA <sup>2</sup> s)	Total Clearing I <sup>2</sup> t @ U <sub>N</sub> (kA <sup>2</sup> s)	Watt Losses		Tested Interrupting rating
							0.8I <sub>N</sub>	I <sub>N</sub>	
3	1300V	130US3U0315B		315	12	68	42	84	100kA @1300V
		130US3U0350B		350	17	100	43	86	
		130US3U0400B		400	25	145	46.5	93	
		130US3U0450B		450	35.5	205	49.5	99	
		130US3U0500B		500	44	255	55	110	
		130US3U0550B		550	57	330	58.8	116	
		130US3U0630B		630	84	485	62.5	125	
		130US3U0700B		700	110	640	67.5	135	
		130US3U0800B		800	190	1090	68	136	
		130US3U0900B		900	250	1090	75	150	
	1100V	110US3U1000B		1000	370	2130	76	152	150kA @1100V
	1000V	100US3U1100B		1100	445	2430	84	168	150kA @1000V
		100US3U1250B		1250	585	3080	93	186	
	900V	090US3U1400B	-	1400	755	3700	105	210	150kA @900V
	700V	070US3U1600B	-	1600	1430	5740	-	203	180kA @ 700V
	650V	065US3U1800B	-	1800	2040	7150	-	206	120kA @ 650V

Notes: Minimum operating voltage for integrated trip indicator = 20V  
 Microswitch reference : MS 7V 1-5

**Electrical Characteristics:**

**Times vs current characteristics**

The following curves indicate the pre-arcing time for each rated current as a function of RMS value of pre-arcing current I:

- Tolerances on this current ± 8%
- Beyond 30 sec, small overloads must be eliminated by another device.
- 

Curve CC' represents the maximum times taken by the associated device to clear small overloads; only its horizontal line is represented.

Its oblique line must be plotted according to sketch in top right corner:

- The intersection of the fuse and CC' curves indicates the minimum breaking current I<sub>pm</sub> of the fuse.



**Size 0**

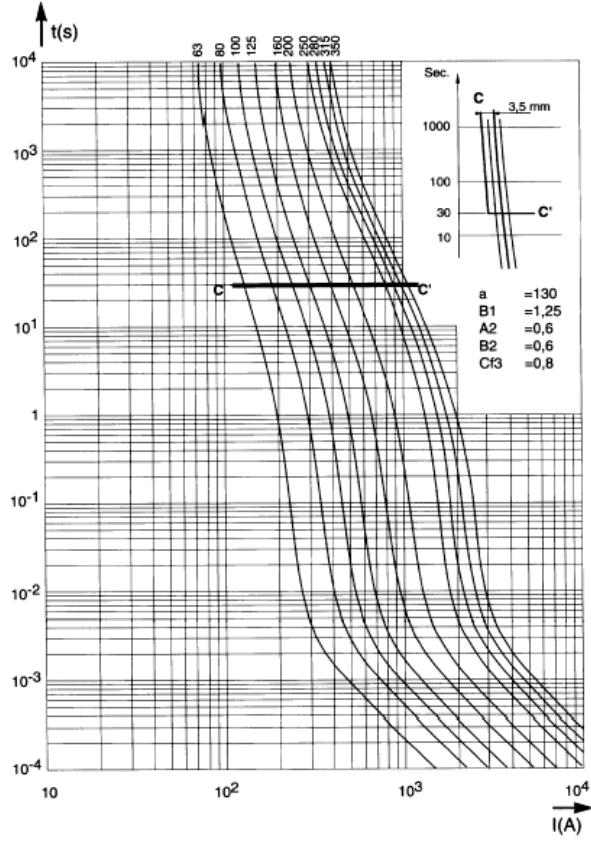

**Size 1**

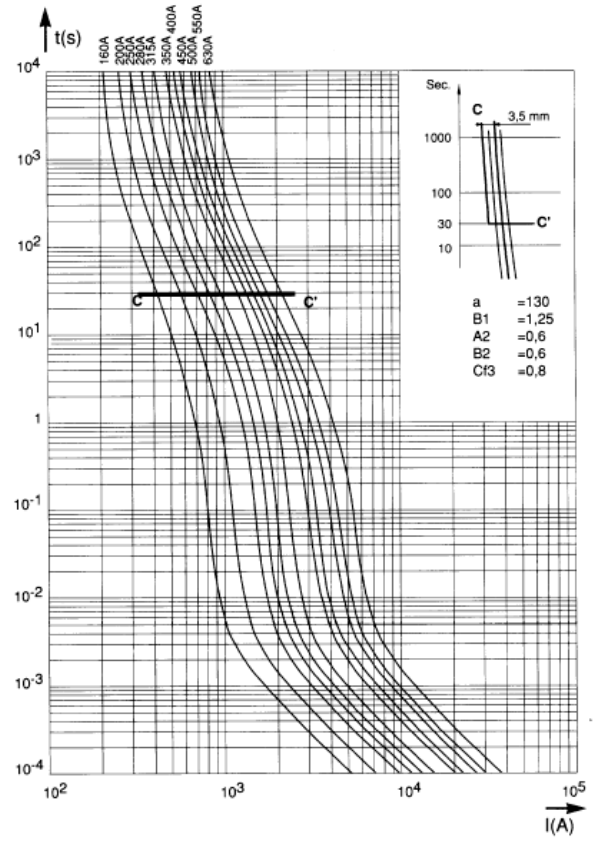

**Size 2**

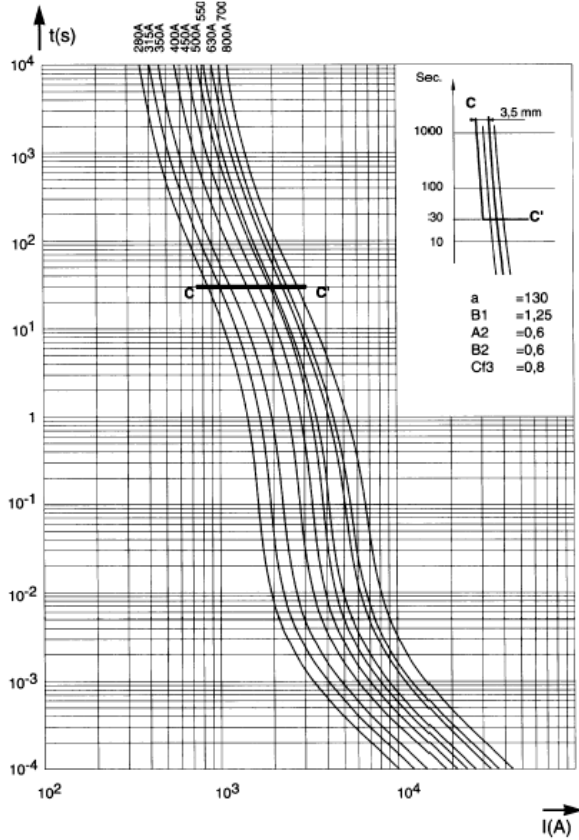

**Size 3**

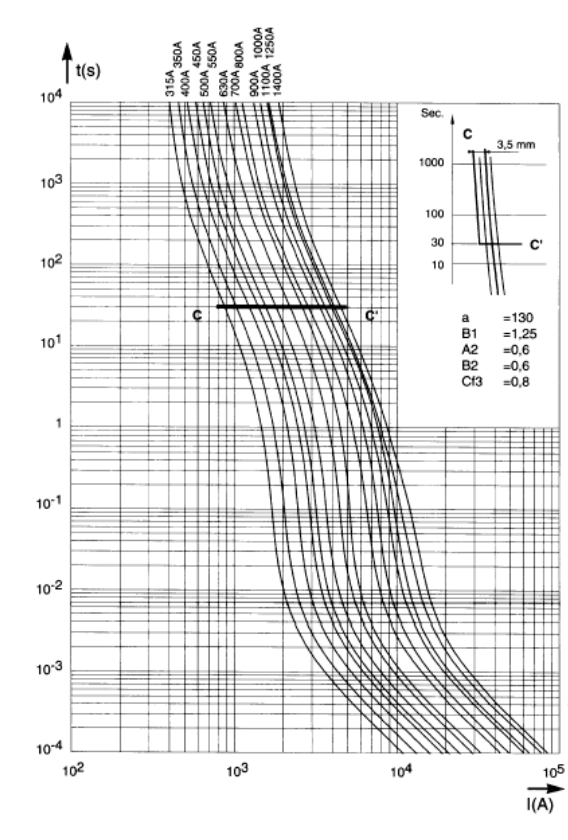

**Total clearing I<sup>2</sup>T:**

The horizontal curves given below indicate the maximum values of total operating I<sup>2</sup>t (I<sup>2</sup>t<sub>t</sub>) as a function of prospective current I<sub>p</sub> @ 1000V or 850V, cosφ = 0.15.

Oblique lines indicate the corresponding total operating time T<sub>t</sub>, with pre-arcing time in brackets.

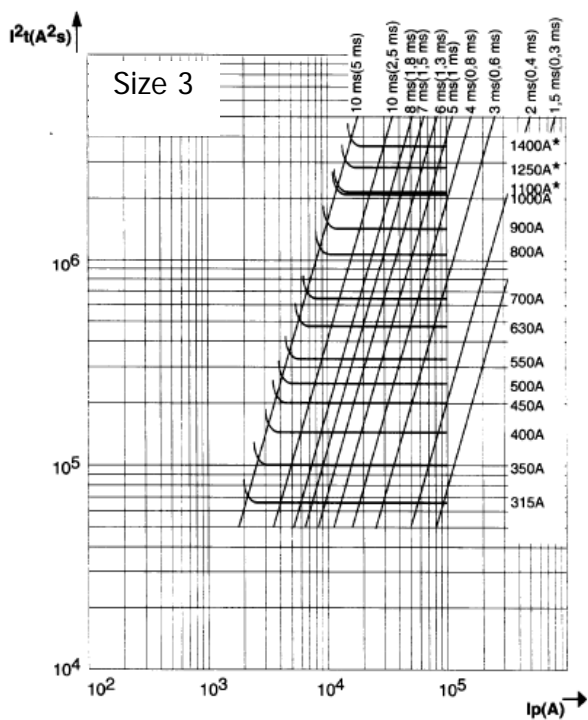
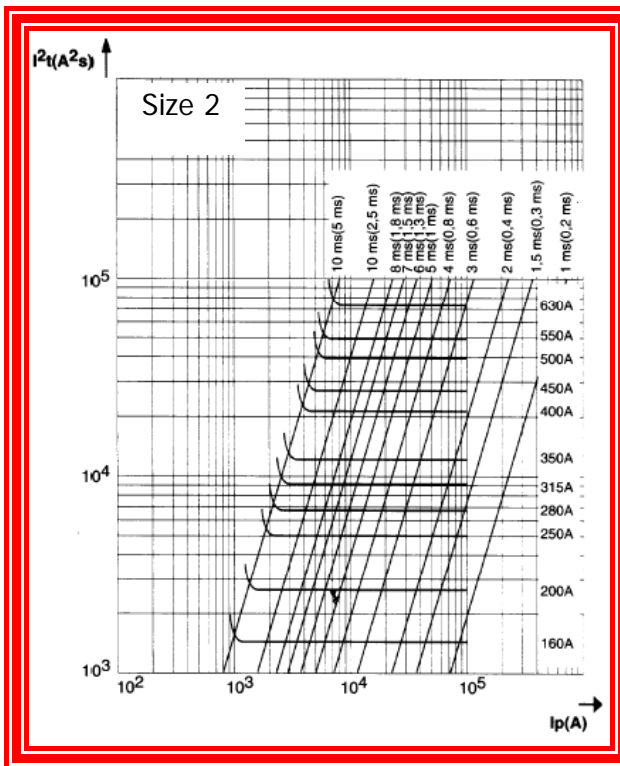
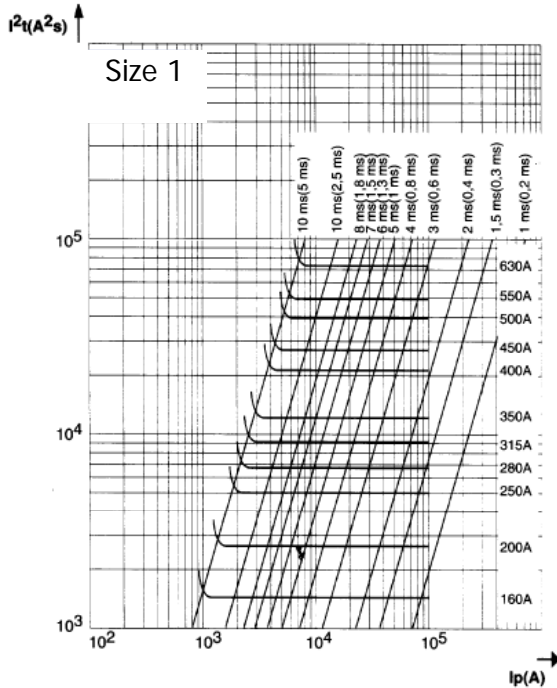
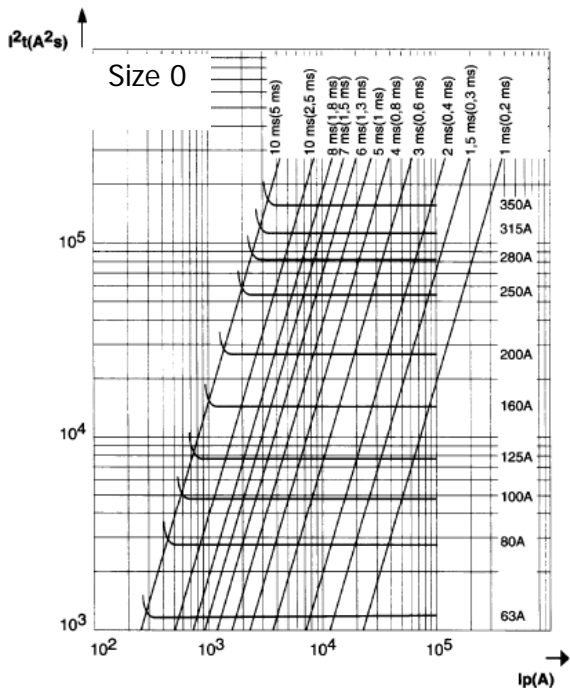

**Cut off Characteristics:**

The curves below indicate, for each rated current, the peak value  $I_c$  that the current may reach as a function of the prospective fault current  $I_p$ .

**Size 0**

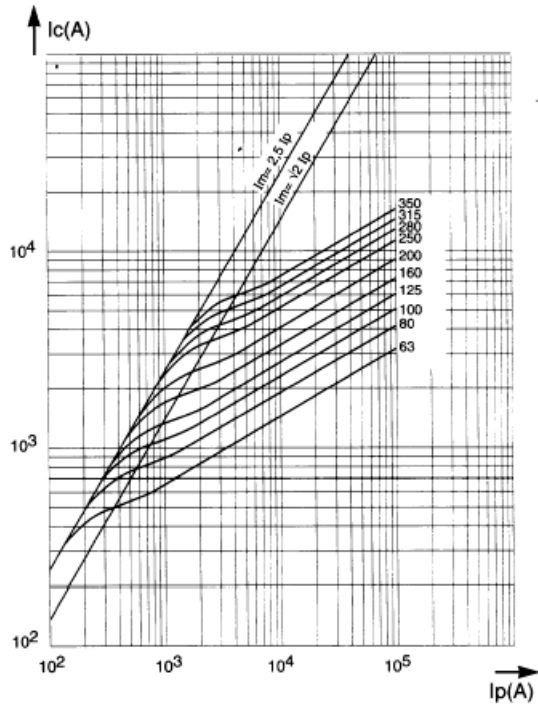

**Size 1**

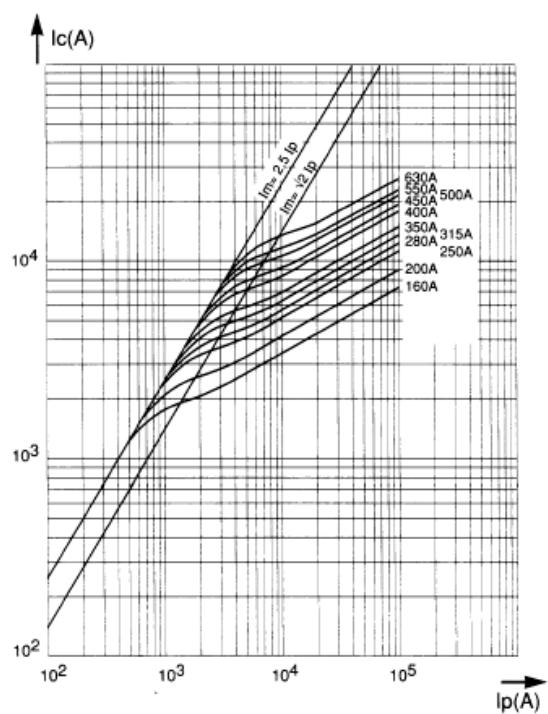

**Size 2**

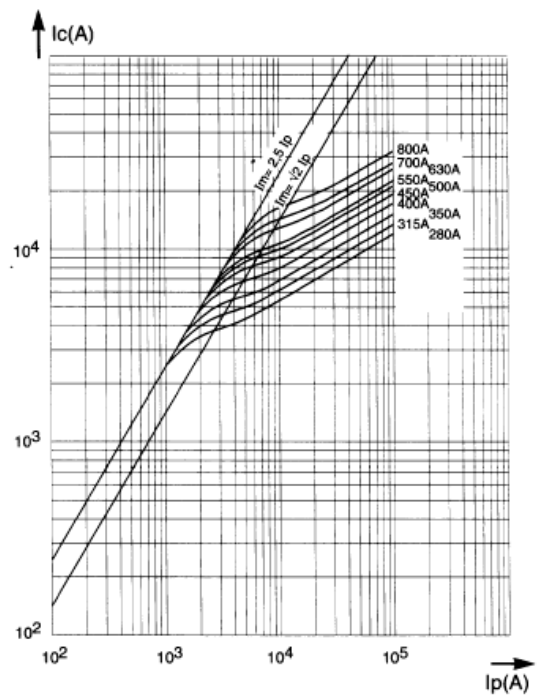

**Size 3**

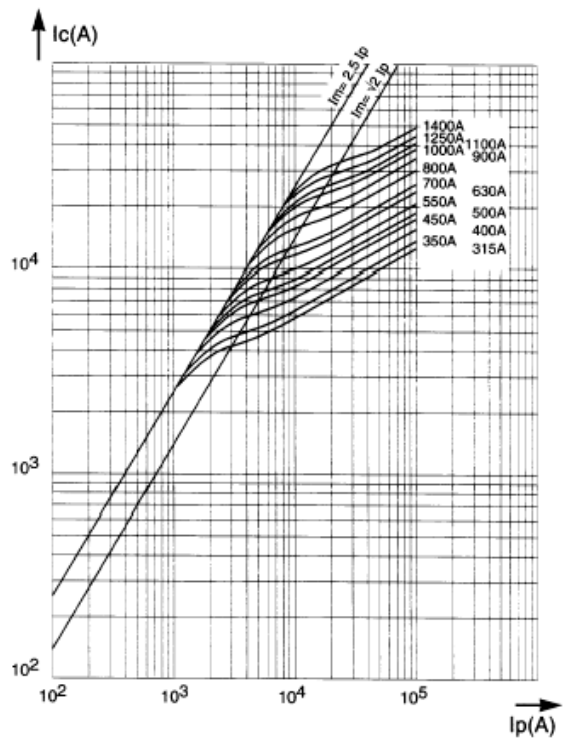

**Corrective Factor – Peak Arc Voltage:**

**Multiplier Coefficient:**

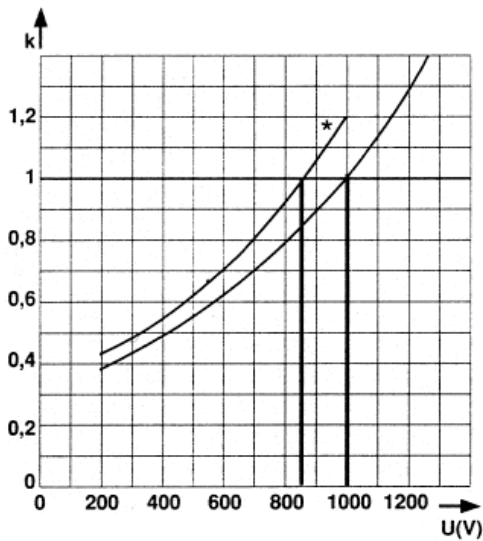

**Arc Voltage:**

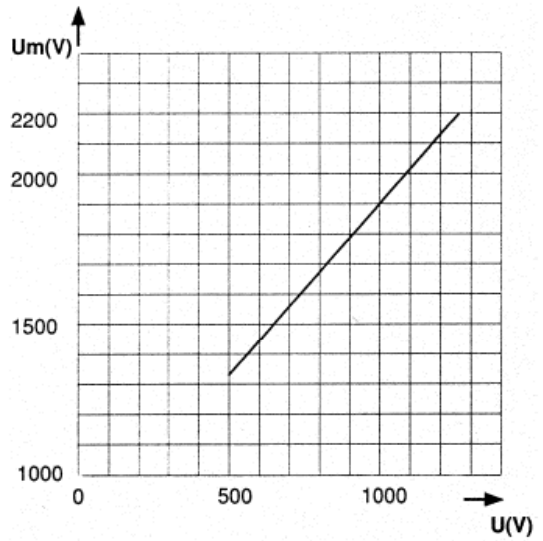

The above Mean curve shows variation of total  $I^2t$  ( $I^2t_t$ ) and total operating time  $T_t$  in accordance with working voltage  $U$ .

Curve indicating peak arc voltage  $U_m$  which may appear across fuse terminals as a function of working voltage  $U$  @  $\cos \varphi = 0.15$

**Dissipated Power:**

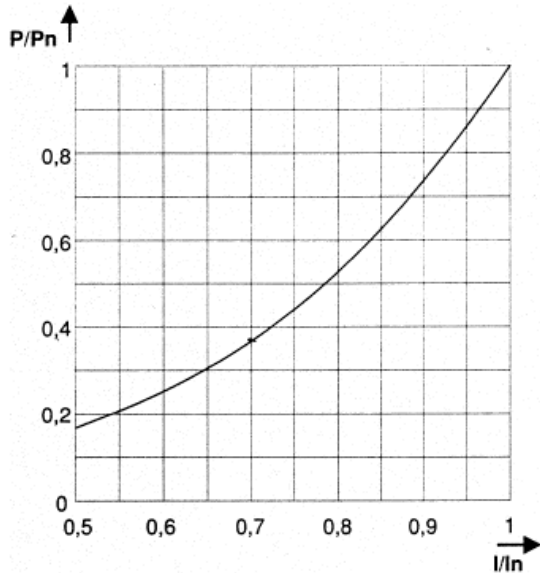

Curve enabling calculation of dissipated power  $P$  by a fuse rated  $I_N$ , as a function of the RMS current  $I$ , in multiples of  $I_N$ , in a steady state.

**Outline Drawing & Ordering Information**

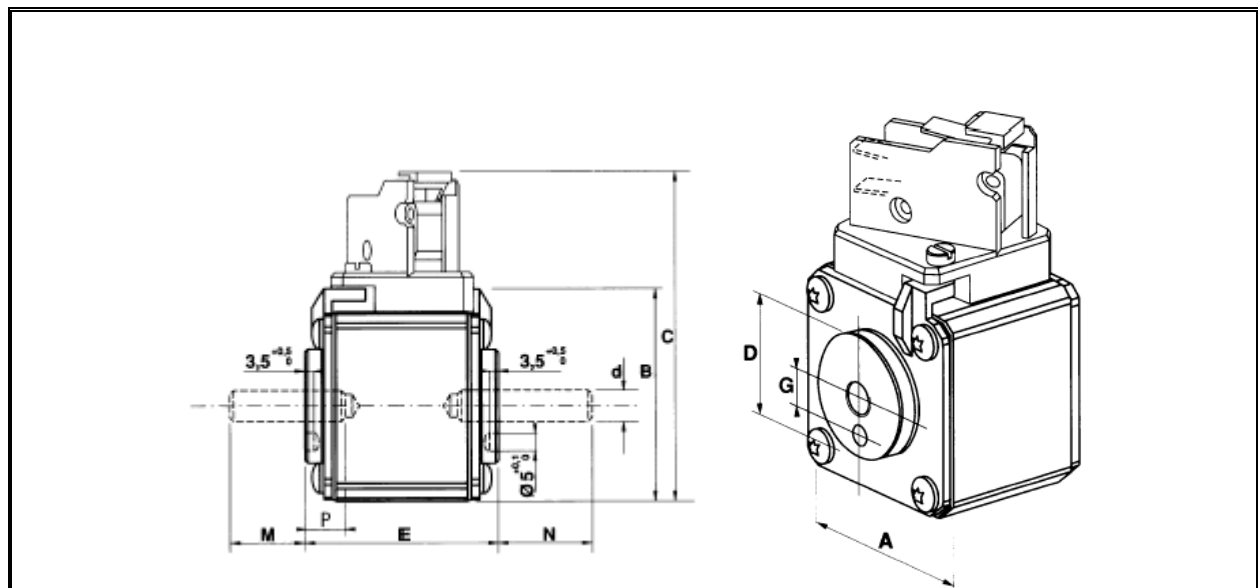

Dimensions (mm / inches)

Size	A	B	C	D	E	d	G	P	Weight
0	40 1-9/16"	46.5 1-27/32"	82 3-7/32"	26 1-1/4"	74 2-29/32"	M8 5-16/18"	9 23/64"	6 15/64"	350g
1	51 2"	56.5 2-7/32"	91 3-37/64"	30 1-3/16"	74 2-29/32"	M8 5-16/18"	9 23/64"	9 23/64"	500g
2	60 2-3/8"	65.5 2-37/64"	100 3-15/16"	38 (* 42) 1-1/2" (1-21/32")	74 2-29/32"	M10 3-8/16"	15 19/32"	9 23/64"	760g / 850g
3	74.5 2-15/16"	79.5 3-1/8"	114 4-1/2"	46 (* 52) 1-13/16" (2-1/16")	74 2-29/32"	M12 1-2/13"	15 19/32"	9 23/64"	1130g / 1250g

(\* ) size 2 from 900A and size 3 from 1250A

**ORDERING INFORMATION**

(Please quote code as below)

Voltage Rating (V)	Type	Size	Fixing	Current Rating (A)	Indicator
9650 – 1300	US	0, 1, 2, 3	U	0063 – 1800	B

Order code: e.g. **130US2U0400B** = 1300V, American Square Body, Size 2, imperial threaded hole, 400A with button indicator

**IXYS Semiconductor GmbH**  
 Edisonstraße 15  
 D-68623 Lampertheim  
 Tel: +49 6206 503-0  
 Fax: +49 6206 503-627  
 E-mail: [marcom@ixys.de](mailto:marcom@ixys.de)



An IXYS Company

**Westcode Semiconductors Ltd**  
 Langley Park Way Langley Park  
 Chippenham Wiltshire SN15 1GE  
 Tel: +44 (0)1249 444524  
 Fax: +44 (0)1249 659448  
 E-mail: [WSL.sales@westcode.com](mailto:WSL.sales@westcode.com)

**IXYS Corporation**  
 3540 Bassett Street  
 Santa Clara CA 95054 USA  
 Tel: +1 (408) 982 0700  
 Fax: +1 (408) 496 0670  
 E-mail: [sales@ixys.com](mailto:sales@ixys.com)

[www.westcode.com](http://www.westcode.com)

[www.ixys.com](http://www.ixys.com)

**Westcode Semiconductors Inc**  
 3270 Cherry Avenue  
 Long Beach CA 90807 USA  
 Tel: +1 (562) 595 6971  
 Fax: +1 (562) 595 8182  
 E-mail: [WSI.sales@westcode.com](mailto:WSI.sales@westcode.com)

The information contained herein is confidential and is protected by Copyright. The information may not be used or disclosed except with the written permission of and in the manner permitted by the proprietors Westcode Semiconductors Ltd.

© Westcode Semiconductors Ltd.

In the interest of product improvement, Westcode reserves the right to change specifications at any time without prior notice.

# WESTCODE

An IXYS Company

Date:- 18 Mar, 2005

Data Sheet Issue:- 1

## Ultra Rapid Semiconductor Protection Fuse American Square Body Type















American Short Blades  
Voltage Rating 700V  
Current Rating 50A to 1600A  
Sizes 0, 1, 2, 3















### Key Features:

- ❖ 690V voltage rating complying with IEC, DIN and VDE standards
- ❖ Exceptionally low  $I^2t$ , power losses
- ❖ Non Magnetic construction, highly reliable low voltage indicator system
- ❖ Conform to UL, IEC, DIN and VDE standards
- ❖ Increased technical performance give higher ratings and a reduction in volume and weight
- ❖ All models with integrated trip-indicator
- ❖ Microswitch system reference MS 3V 1-5









**Main Characteristics:**

Size	Voltage U <sub>N</sub> (V)	Ref:		Current rating I <sub>N</sub> (A)	Pre-arcing I <sup>2</sup> t @ 1 ms I <sup>2</sup> t <sub>p</sub> (kA <sup>2</sup> s)	Total Clearing I <sup>2</sup> t @ U <sub>N</sub> (kA <sup>2</sup> s)	Watt Losses		Tested Interrupting rating
							0.8I <sub>N</sub>	I <sub>N</sub>	
0	700V	070US0B0050B		50	0.12	0.68	4.5	9	170kA @700V
		070US0B0063B		63	0.20	1.1	7.5	14	
		070US0B0080B		80	0.33	1.8	9.5	19	
		070US0B0100B		100	0.47	2.5	13	26	
		070US0B0125B		125	0.85	4.5	15	30	
		070US0B0160B		160	1.6	8.5	18.5	37	
		070US0B0200B		200	3	15.5	21.5	43	
		070US0B0250B		250	5.8	30	25	50	
		070US0B0315B		315	12	62	22.5	55	
		070US0B0350B		350	15.5	80	30	60	
		070US0B0400B		400	23	120	32.5	65	
		070US0B0450B		450	26	150	44	88	
		070US0B0500B		500	41	240	44	88	
		070US0B0550B		-	550	52	300	45	











Notes: Minimum operating voltage for integrated trip indicator = 20V  
 Microswitch reference : MS 3V 1-5  
 Shaded data; not included on curves, refer to factory

Size	Voltage U <sub>N</sub> (V)	Ref:		Current rating I <sub>N</sub> (A)	Pre-arcing I <sup>2</sup> t @ 1 ms I <sup>2</sup> t <sub>p</sub> (kA <sup>2</sup> s)	Total Clearing I <sup>2</sup> t @ U <sub>N</sub> (kA <sup>2</sup> s)	Watt Losses		Tested Interrupting rating
							0.8I <sub>N</sub>	I <sub>N</sub>	
1	700V	070US1B0160B		160	1.3	7.0	27.5	35	170kA @700V
		070US1B0200B		200	2.6	13.5	22.5	45	
		070US1B0250B		250	4.7	25	25.5	52	
		070US1B0315B		315	7.5	40	32.5	65	
		070US1B0350B		350	10.5	55	33.5	67	
		070US1B0400B		400	19	100	34	68	
		070US1B0450B		450	26.5	140	35	70	
		070US1B0500B		500	37	195	36	72	
		070US1B0550B		550	52	280	37.5	75	
		070US1B0630B		630	75	390	42.5	85	
		070US1B0700B		700	95	490	42.5	95	
		070US1B0800B		800	140	800	60	120	

Notes: Minimum operating voltage for integrated trip indicator = 20V  
 Microswitch reference : MS 3V 1-5  
 Shaded data; not included on curves, refer to factory

Size	Voltage U <sub>N</sub> (V)	Ref:		Current rating I <sub>N</sub> (A)	Pre-arcing I <sup>2</sup> t @ 1 ms I <sup>2</sup> t <sub>p</sub> (kA <sup>2</sup> s)	Total Clearing I <sup>2</sup> t @ U <sub>N</sub> (kA <sup>2</sup> s)	Watt Losses		Tested Interrupting rating
							0.8I <sub>N</sub>	I <sub>N</sub>	
2	700V	070US2B0400B		400	15	80	32.5	75	170kA @700V
		070US2B0450B		450	20	115	40	80	
		070US2B0500B		500	28	145	45	90	
		070US2B0550B		550	37	195	47.5	95	
		070US2B0630B		630	54	280	52.5	105	
		070US2B0700B		700	76	400	55	110	
		070US2B0800B		800	115	600	60	120	
		070US2B0900B		900	170	900	62.5	125	200kA @ 700V
		070US2B1000B		1000	240	1250	67.5	135	

Notes: Minimum operating voltage for integrated trip indicator = 20V  
Microswitch reference : MS 3V 1-5

Size	Voltage U <sub>N</sub> (V)	Ref:		Current rating I <sub>N</sub> (A)	Pre-arcing I <sup>2</sup> t @ 1 ms I <sup>2</sup> t <sub>p</sub> (kA <sup>2</sup> s)	Total Clearing I <sup>2</sup> t @ U <sub>N</sub> (kA <sup>2</sup> s)	Watt Losses		Tested Interrupting rating	
							0.8I <sub>N</sub>	I <sub>N</sub>		
3	700V	070US3B0500B		500	19	100	52.5	105	170kA @700V	
		070US3B0550B		550	27	140	55	110		
		070US3B0630B		630	40	210	60	120		
		070US3B0700B		700	55	300	62.5	125		
		070US3B0800B		800	95	490	65	130		
		070US3B0900B		900	135	700	67.5	135		
		070US3B1000B		1000	170	900	77.5	155		
		070US3B1100B		1100	240	1260	80	160		
		070US3B1250B		1250	350	1850	90	180		200kA @ 700V
		070US3B1400B		1400	480	2500	100	200		
	650V	065US3B1600B		1600	500	3000	120	240	160kA @ 650V	

Notes: Minimum operating voltage for integrated trip indicator = 20V  
Micro switch reference : MS 3V 1-5  
Shaded data; not included on curves, refer to factory

**Electrical Characteristics:**

**Times vs current characteristics**

The curves shown on page 4 indicate the pre-arcing time for each rated current as a function of RMS value of pre-arcing current I:

- Tolerances on this current ± 8%
- Beyond 30 sec or 10 sec, small overloads must be eliminated by another device.

Curve CC' represents the maximum times taken by the associated device to clear small overloads; only its horizontal line is represented.

Its oblique line must be plotted according to sketch in top right corner:

- The intersection of the fuse and CC' curves indicates the minimum breaking current I<sub>pm</sub> of the fuse.



**Times vs current characteristics**

Size 0

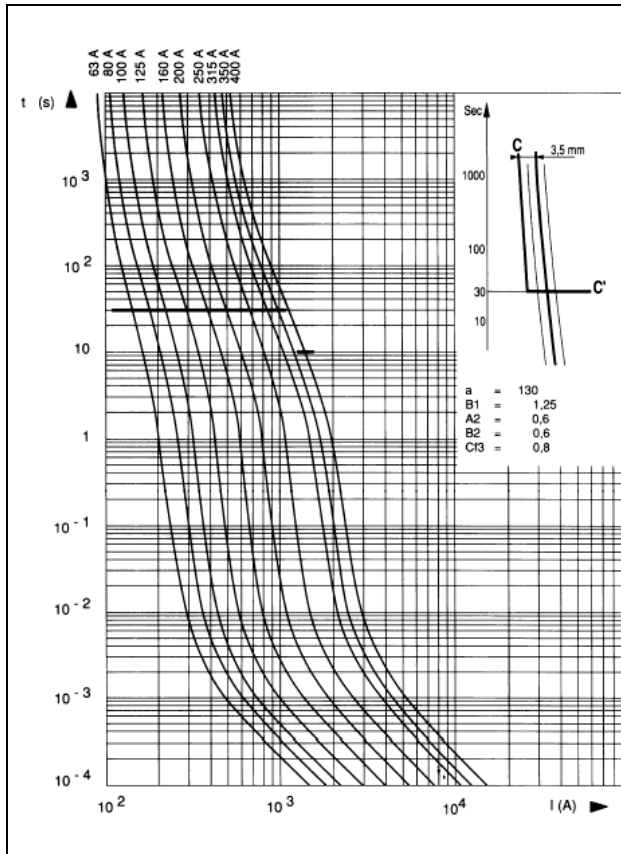

Size 1

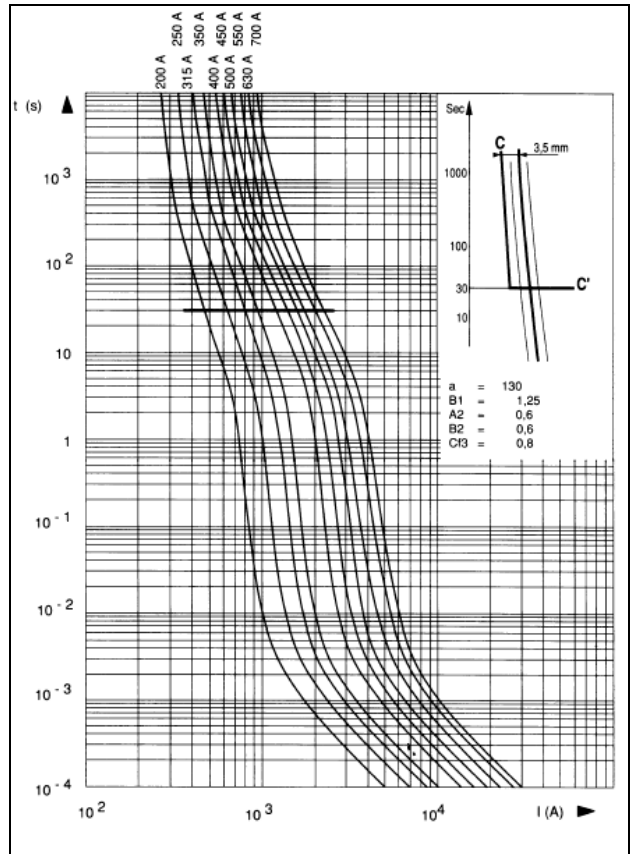

Size 2

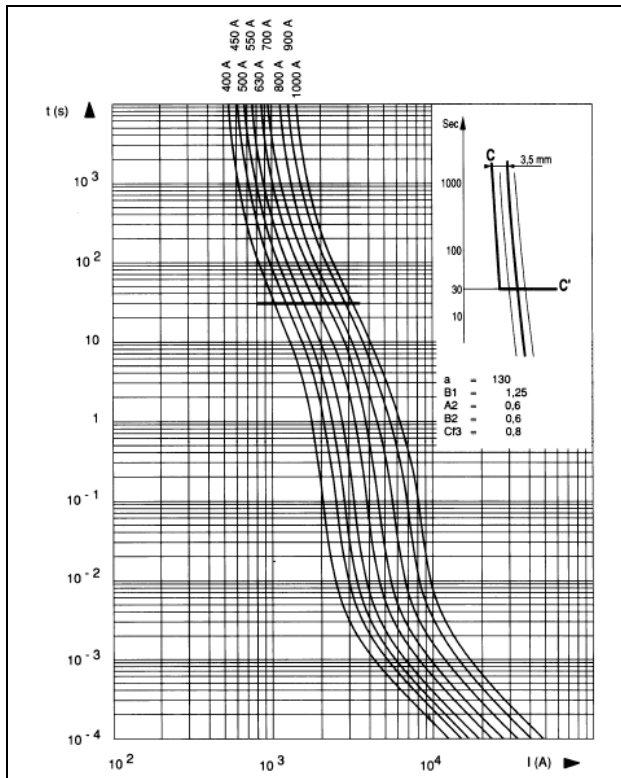

Size 3

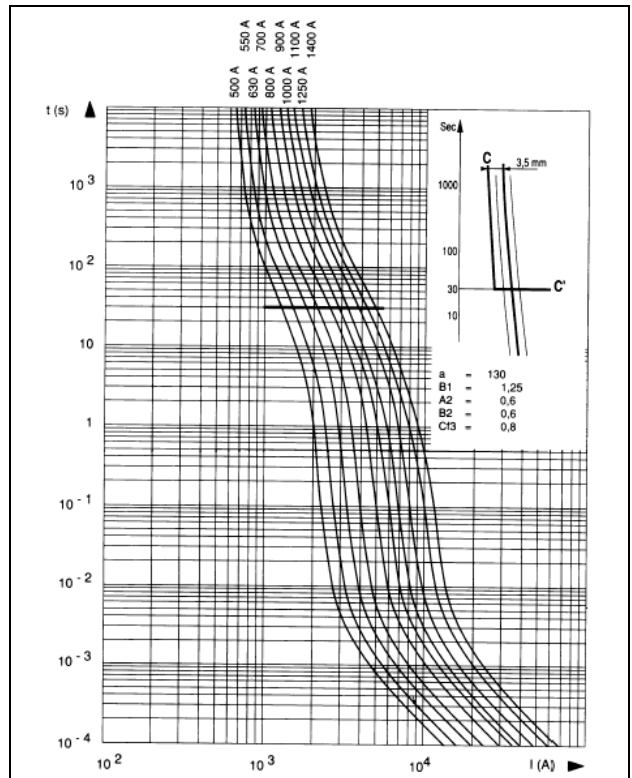

**Total clearing I<sup>2</sup>T:**

The horizontal curves given below indicated the maximum values of total operating I<sup>2</sup>t (I<sup>2</sup>t<sub>t</sub>) as a function of prospective current I<sub>p</sub> @ 660V, cosφ = 0.15. Oblique lines indicate the corresponding total operating time T<sub>t</sub>, with pre-arcing time in brackets.

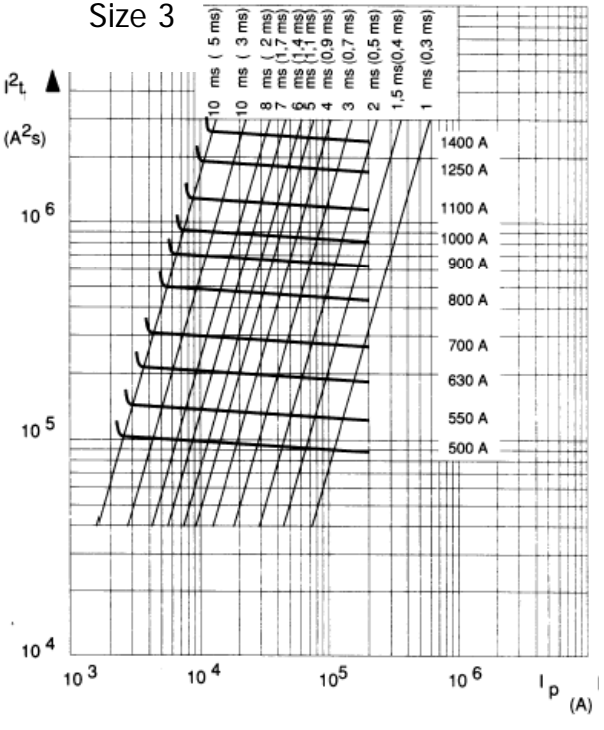
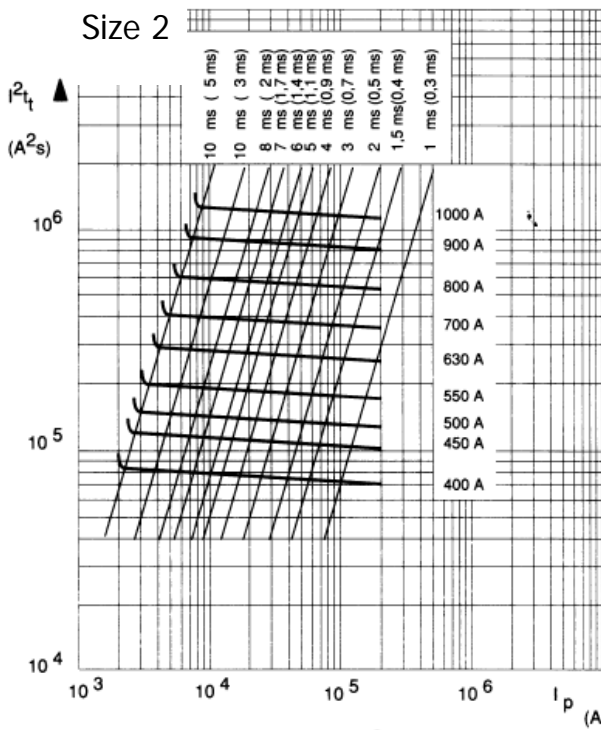
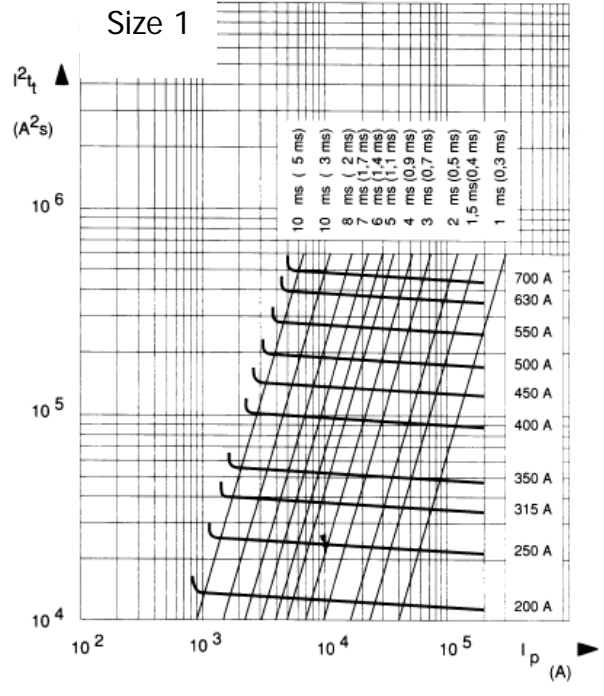
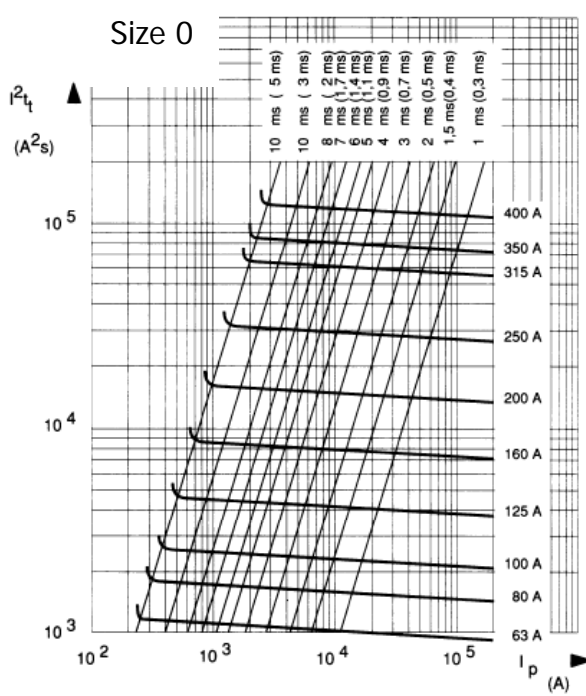

**Cut off Characteristics:**

The curves below indicate, for each rated current, the peak value  $I_c$  that the current may reach as a function of the prospective fault current  $I_p$ .

Size 0

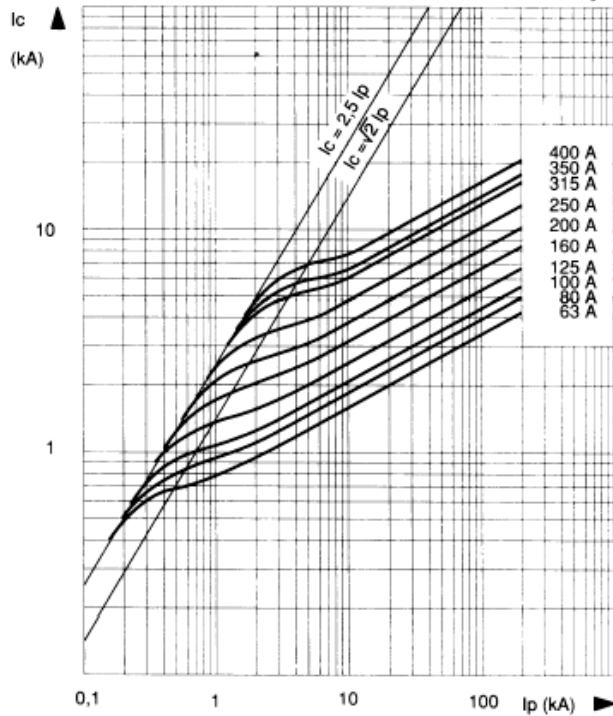

Size 1

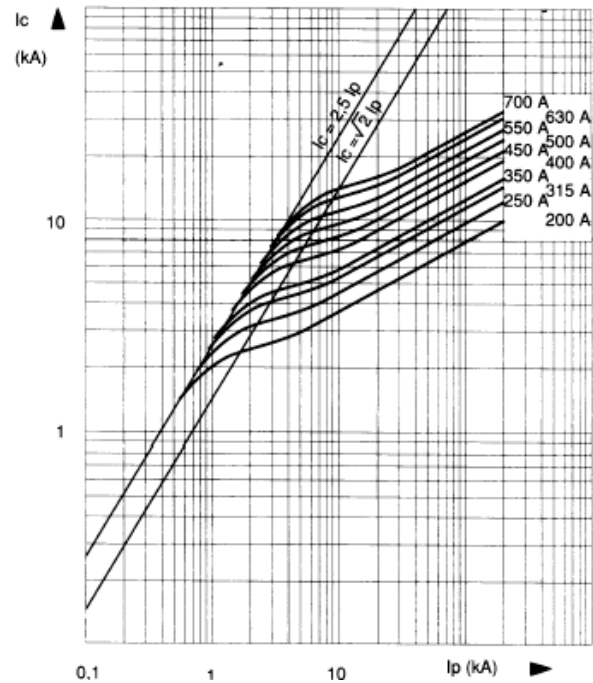

Size 2

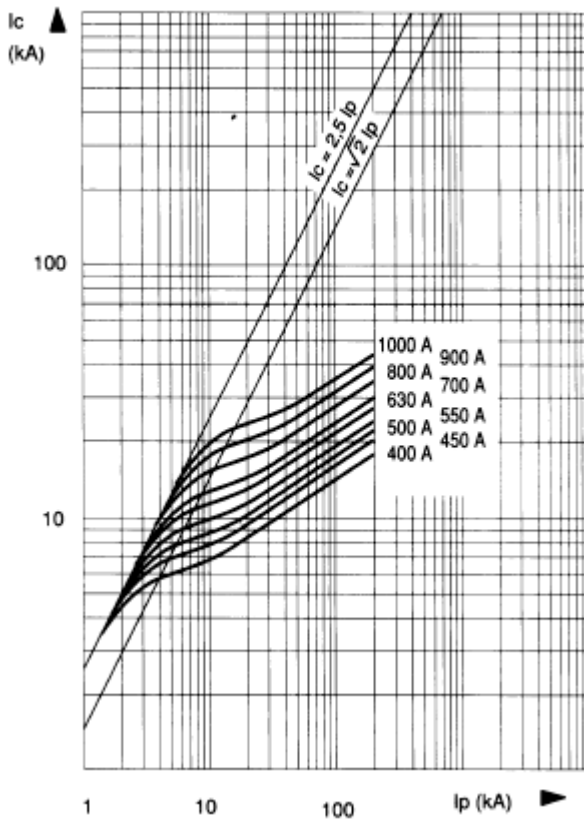

Size 3

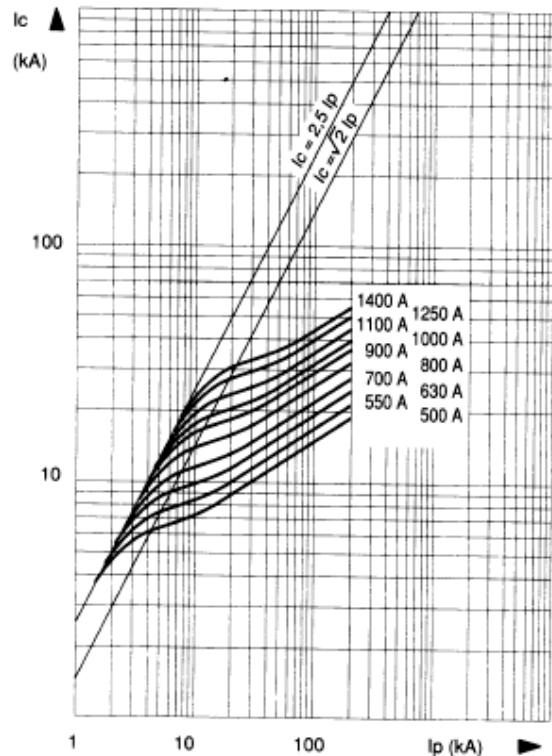

**Corrective Factor – Peak Arc Voltage:**

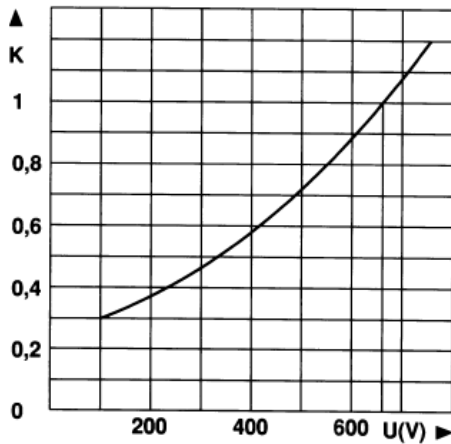

The above Mean curve shows variation of total clearing time  $I^2t$  ( $I^2t_t$ ) and total operating time  $T_t$  in accordance with working voltage  $U$ .

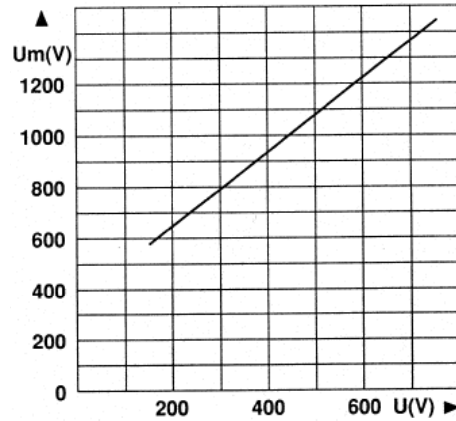

Curve indicating peak arc voltage  $U_m$  which may appear across fuse terminals as a function of working voltage  $U$  @  $\cos \varphi = 0.15$ .

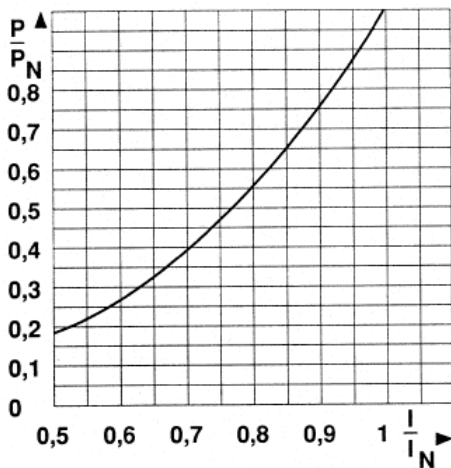

Curve enabling calculation of dissipated power  $P$  by a fuse rated  $I_N$ , as a function of the RMS current  $I$ , in multiples of  $I_N$  in a steady state.

**Outline Drawing & Ordering Information:**

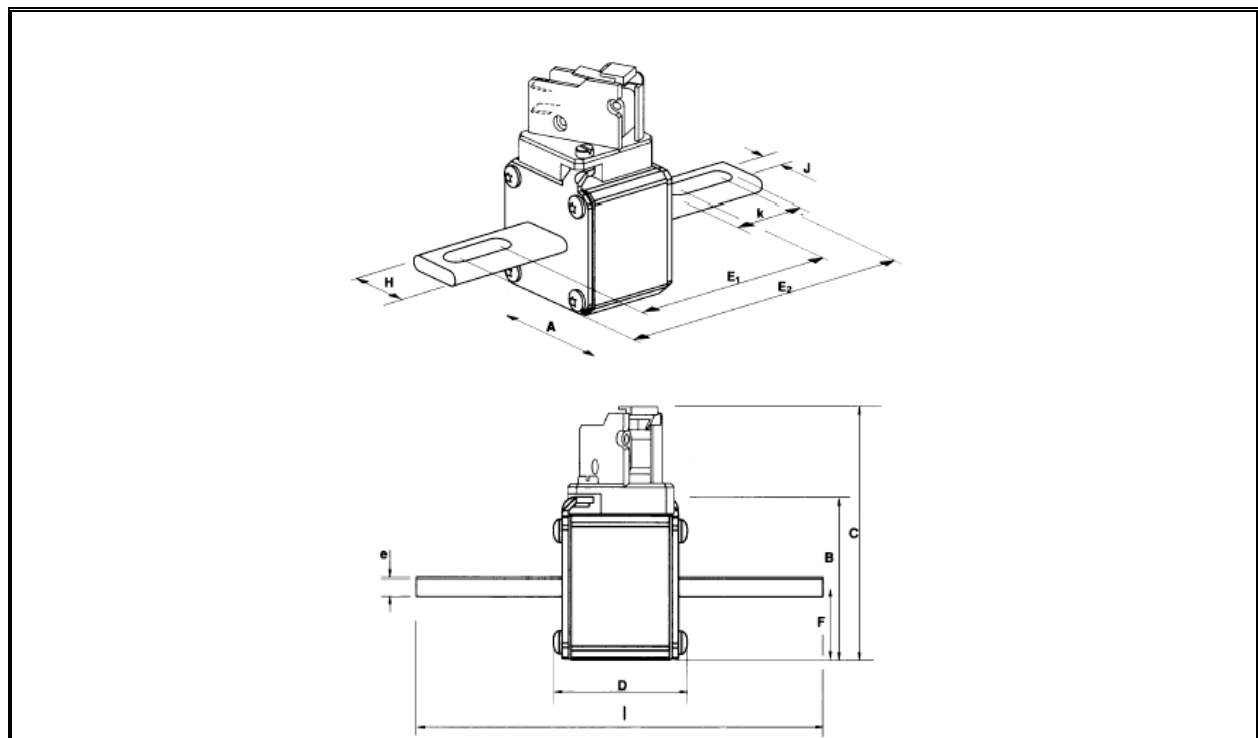

**Dimensions (mm)**

Size	A	B	C	D	E <sub>1</sub>	E <sub>2</sub>	F	H	J	K	L	e	Weight
0	40	46.5	82	47.5	68	107	21	25	10.5	30	129	6	290g
1	51	56.5	91	47.5	68	107	25.5	25	10.5	30	129	6	430g
2	60	65.5	100	47.5	74.5	109	30	32	14.6	32	134	6	590g / 660g
3	74.5	79.5	114	48.5	75.4	107.6	37.2	40	15.9	32	134	6	860g / 1070g

**ORDERING INFORMATION**

(Please quote code as below)

Voltage Rating (V)	Type	Size	Fixing	Current Rating Amps (A)	Indicator Type
700	US	0, 1, 2, or 3	B	0050 – 1600	B

Order code: eg. **070US3B0063B** = 700V, American Square Body with Short Blades, Size 3, 90mm fixing diameter, 63A with button indicator

**IXYS Semiconductor GmbH**  
 Edisonstraße 15  
 D-68623 Lampertheim  
 Tel: +49 6206 503-0  
 Fax: +49 6206 503-627  
 E-mail: [marcom@ixys.de](mailto:marcom@ixys.de)

**WESTCODE**  
 An  IXYS Company

**Westcode Semiconductors Ltd**  
 Langley Park Way Langley Park  
 Chippenham Wiltshire SN15 1GE  
 Tel: +44 (0)1249 444524  
 Fax: +44 (0)1249 659448  
 E-mail: [WSL.sales@westcode.com](mailto:WSL.sales@westcode.com)

**IXYS Corporation**  
 3540 Bassett Street  
 Santa Clara CA 95054 USA  
 Tel: +1 (408) 982 0700  
 Fax: +1 (408) 496 0670  
 E-mail: [sales@ixys.com](mailto:sales@ixys.com)

[www.westcode.com](http://www.westcode.com)  
[www.ixys.com](http://www.ixys.com)

**Westcode Semiconductors Inc**  
 3270 Cherry Avenue  
 Long Beach CA 90807 USA  
 Tel: +1 (562) 595 6971  
 Fax: +1 (562) 595 8182  
 E-mail: [WSI.sales@westcode.com](mailto:WSI.sales@westcode.com)

The information contained herein is confidential and is protected by Copyright. The information may not be used or disclosed except with the written permission of and in the manner permitted by the proprietors Westcode Semiconductors Ltd.

© Westcode Semiconductors Ltd.

In the interest of product improvement, Westcode reserves the right to change specifications at any time without prior notice.

## Ultra Rapid Semiconductor Protection Fuse American Square Body Type Fuses

**American Long Blades**  
**Voltage Ratings 450V to 700V**  
**Current Ratings 50A to 2500A**  
**Sizes 0, 1, 2, 3**



### **Key Features:**

- ❖ 690V voltage rating complying with IEC, DIN and VDE standards
- ❖ Exceptionally low  $I^2t$ , power losses
- ❖ Non Magnetic construction, highly reliable low voltage indicator system
- ❖ Conform to UL, IEC, DIN and VDE standards
- ❖ Increased technical performance give higher ratings and a reduction in volume and weight
- ❖ All models with integrated trip-indicator
- ❖ Microswitch system reference MS 3V 1-5















**Main Characteristics:**

Size	Voltage U <sub>N</sub> (V)	Ref:		Current rating I <sub>N</sub> (A)	Pre-arcing I <sup>2</sup> t @ 1 ms I <sup>2</sup> t <sub>p</sub> (kA <sup>2</sup> s)	Total Clearing I <sup>2</sup> t @ U <sub>N</sub> (kA <sup>2</sup> s)	Watt Losses 0.8I <sub>N</sub> I <sub>N</sub>		Tested Interrupting rating
0	700V	070US0D0063B		63	0.20	1.10	7.5	14	170kA @ 700V
		070US0D0080B		80	0.33	1.8	9.5	19	
		070US0D0100B		100	0.47	2.5	13	26	
		070US0D0125B		125	0.85	4.5	15	30	
		070US0D0160B		160	1.6	8.5	18.5	37	
		070US0D0200B		200	3	15.5	21.5	43	
		070US0D0250B		250	5.8	30	25	50	
		070US0D0315B		315	12	62	22.5	55	
		070US0D0350B		350	15.5	80	30	60	
		070US0D0400B		400	23	120	32.5	65	
		070US0D0450B		450	26	150	44	88	
		070US0D0500B		500	41	240	44	88	
		070US0D0550B	-	550	52	300	45	90	

















Notes: Minimum operating voltage for integrated trip indicator = 20V Microswitch reference: MS 3V 1-5

Size	Voltage U <sub>N</sub> (V)	Ref:		Current rating I <sub>N</sub> (A)	Pre-arcing I <sup>2</sup> t @ 1 ms I <sup>2</sup> t <sub>p</sub> (kA <sup>2</sup> s)	Total Clearing I <sup>2</sup> t @ U <sub>N</sub> (kA <sup>2</sup> s)	Watt Losses 0.8I <sub>N</sub> I <sub>N</sub>		Tested Interrupting rating
1	700V	070US1D0200B		200	2.60	13.50	22.5	45	170kA / 700V
		070US1D0250B		250	4.70	25.00	25.5	52	
		070US1D0315B		315	7.50	40.00	32.5	65	
		070US1D0350B		350	10.50	55.00	33.5	67	
		070US1D0400B		400	19.00	100.00	34.0	68	
		070US1D0450B		450	26.50	140.00	35.0	70	
		070US1D0500B		500	37.00	195.00	36.0	72	
		070US1D0550B		550	52.00	280.00	37.5	75	
		070US1D0630B		630	75.00	390.00	42.5	85	
		070US1D0700B		700	95.00	490.00	42.5	95	
		070US1D0800B		800	140.00	800.00	60.0	120	

Notes: Minimum operating voltage for integrated trip indicator = 20V  
Microswitch reference: MS 3V 1-5

Size	Voltage U <sub>N</sub> (V)	Ref:		Current rating I <sub>N</sub> (A)	Pre-arcing I <sup>2</sup> t @ 1 ms I <sup>2</sup> t <sub>p</sub> (kA <sup>2</sup> s)	Total Clearing I <sup>2</sup> t @ U <sub>N</sub> (kA <sup>2</sup> s)	Watt Losses		Tested Interrupting rating
							0.8I <sub>N</sub>	I <sub>N</sub>	
2	700V	070US2D0400B		400	15	80	32.5	75	170 kA / 700V
		070US2D0450B		450	22	115	40	80	
		070US2D0500B		500	28	145	45	90	
		070US2D0550B		550	37	195	47.5	95	
		070US2D0630B		630	54	280	52.5	105	
		070US2D0700B		700	76	400	55	110	
		070US2D0800B		800	115	600	60	120	
	690V +6%	070US2D0900B		900	170	900	62.5	125	200 kA / 700V
		070US2D1000B		1000	240	1250	67.5	135	
	650V	065US2D1100B		1100	270	1670	-	165	160kA @ 650V
	600V	060US2D1250B		1250	410	2400	-	180	150kA @ 600V
	550V	055US2D1400B		1400	555	3400	-	190	130kA @ 550V
		055US2D1600B		1600	870	5300	-	195	
500V	050US2D1800B		1800	1050	8700	-	230	110kA @ 500V	

Notes: Minimum operating voltage for integrated trip indicator = 20V Microswitch reference: MS 3V 1-5

Size	Voltage U <sub>N</sub> (V)	Ref:		Current rating I <sub>N</sub> (A)	Pre-arcing I <sup>2</sup> t @ 1 ms I <sup>2</sup> t <sub>p</sub> (kA <sup>2</sup> s)	Total Clearing I <sup>2</sup> t @ U <sub>N</sub> (kA <sup>2</sup> s)	Watt Losses		Tested Interrupting rating
							0.8I <sub>N</sub>	I <sub>N</sub>	
3	700V	070US3D0500B		500	19	100	52.5	105	170 kA / 750V
		070US3D0550B		550	27	140	55	110	
		070US3D0630B		630	40	210	60	120	
		070US3D0700B		700	55	300	62.5	125	
		070US3D0800B		800	95	490	65	130	
		070US3D0900B		900	135	700	67.5	135	
		070US3D1000B		1000	170	900	77.5	155	
		070US3D1100B		1100	240	1260	80	160	
	690V +6%	070US3D1250B		1250	350	1850	90	180	200 kA / 700V
		070US3D1400B		1400	480	2500	100	200	
	650V	065UR3D1600B		1600	555	3300	120	240	160kA @ 650V
		065UR3D1800B		1800	720	4450	-	260	
	600V	060UR3D2000B		2000	950	5600	-	290	130kA @ 600V
	550V	055UR3D2250B		2250	1250	7600	-	330	110kA @ 550V
	500V	050UR3D2500B		2500	1870	6540	-	330	110kA @ 500V

Notes: Minimum operating voltage for integrated trip indicator = 20V Microswitch reference: MS 3V 1-5

**Electrical Characteristics:**

**Times vs current characteristics**

The curves shown on page 4 indicate the pre-arcing time for each rated current as a function of RMS value of pre-arcing current I:

- Tolerances on this current ± 8%
- Beyond 30 sec or 10 sec, small overloads must be eliminated by another device.



Curve CC' represents the maximum times taken by the associated device to clear small overloads; only its horizontal line is represented.

Its oblique line must be plotted according to sketch in top right corner:

- The intersection of the fuse and CC' curves indicates the minimum breaking current  $I_{pm}$  of the fuse.

Size 0

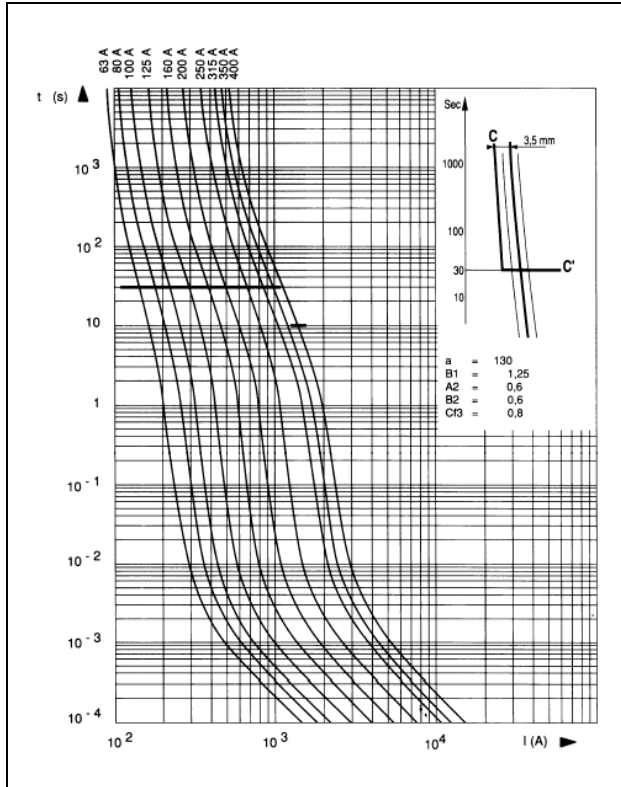

Size 1

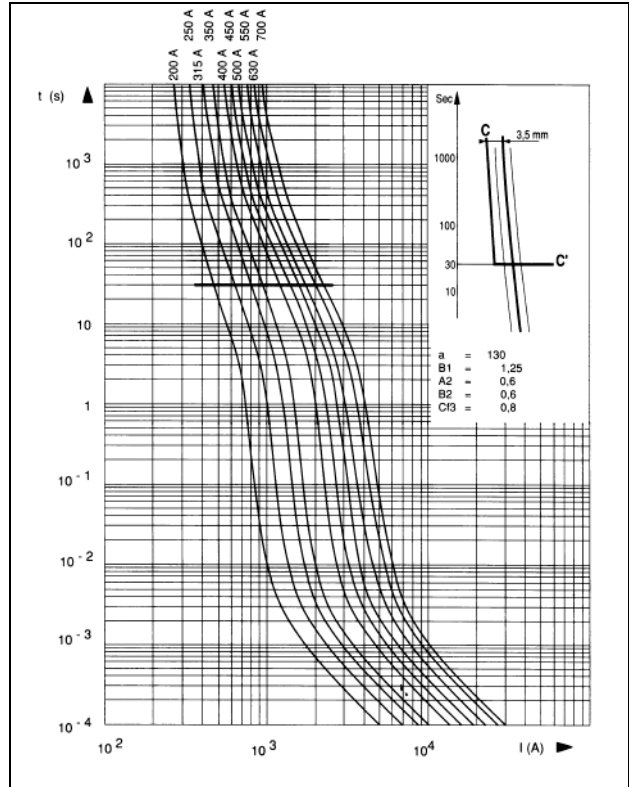

Size 2

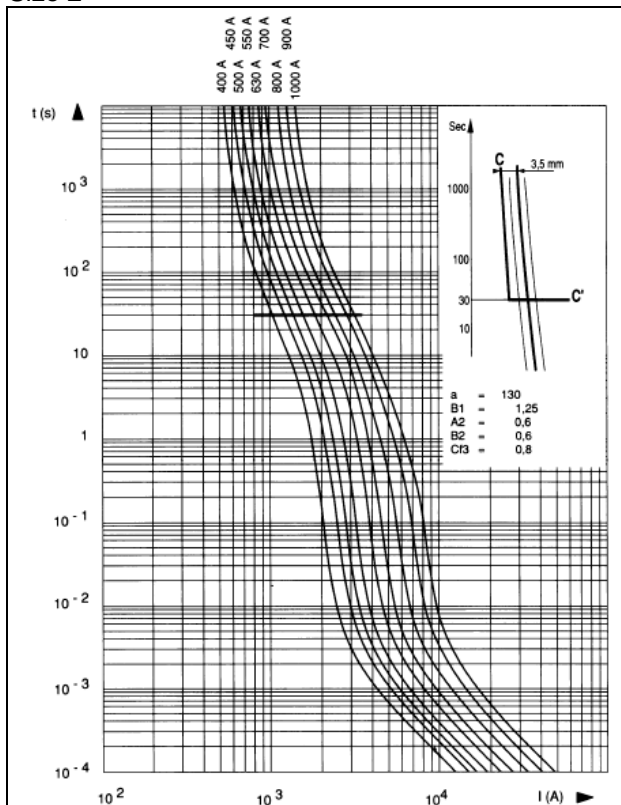

Size 3

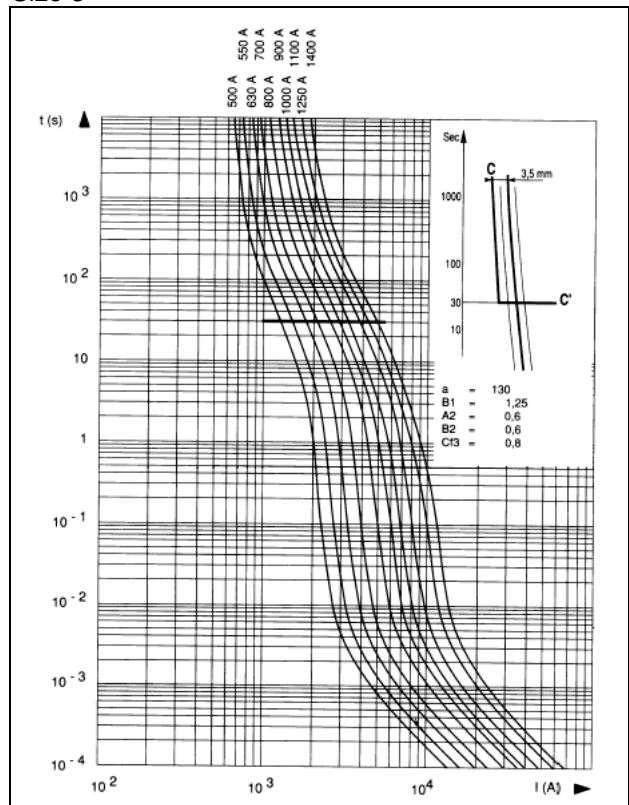

**Total clearing I<sup>2</sup>T:**

The horizontal curves given below indicated the maximum values of total operating I<sup>2</sup>t (I<sup>2</sup>t<sub>t</sub>) as a function of prospective current I<sub>p</sub> @ 660V, cosφ = 0.15. Oblique lines indicate the corresponding total operating time T<sub>t</sub>, with pre-arcing time in brackets.

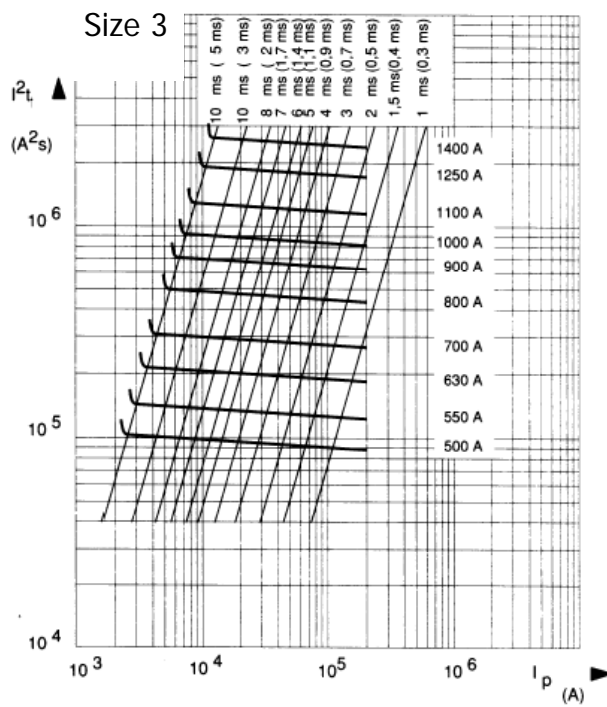
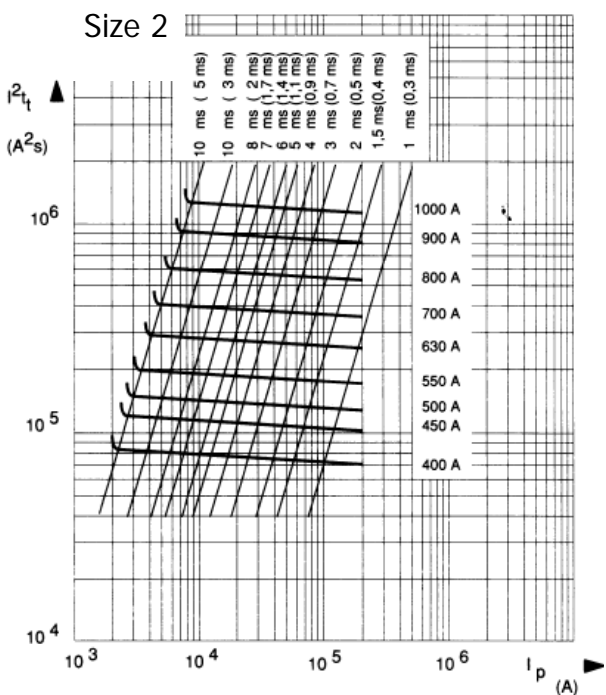
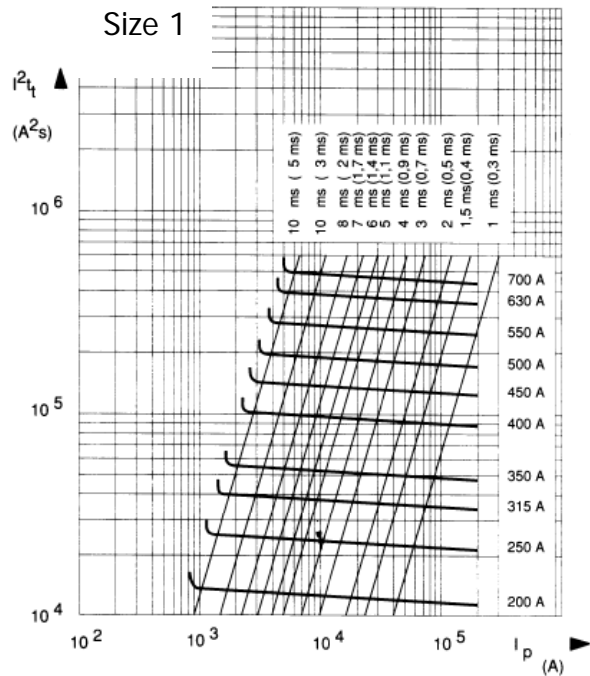
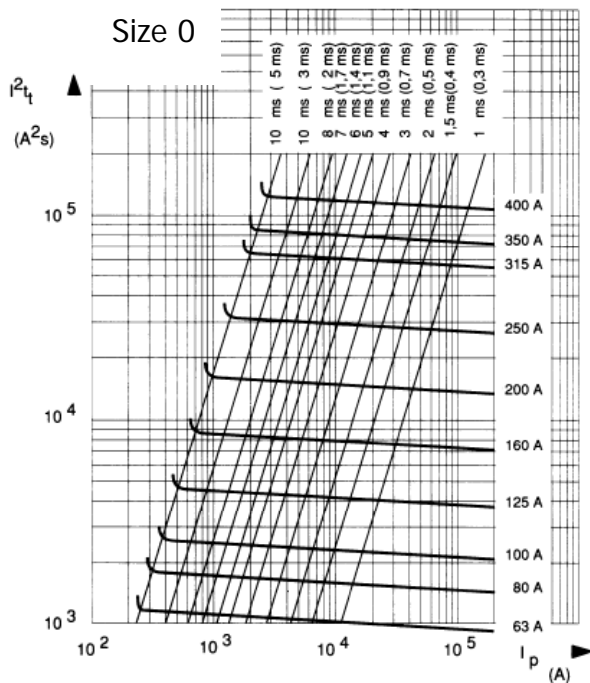

**Cut off Characteristics:**

The curves below indicate, for each rated current, the peak value  $I_c$  that the current may reach as a function of the prospective fault current  $I_p$ .

Size 0

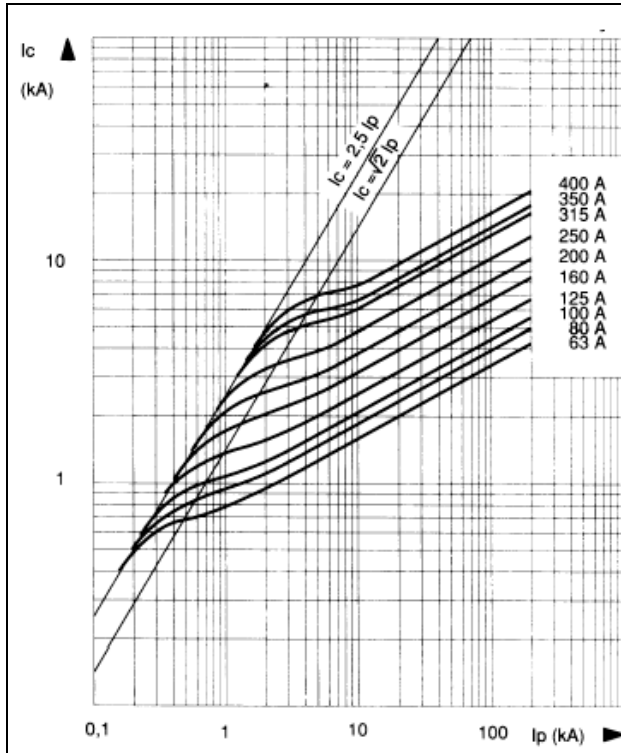

Size 1

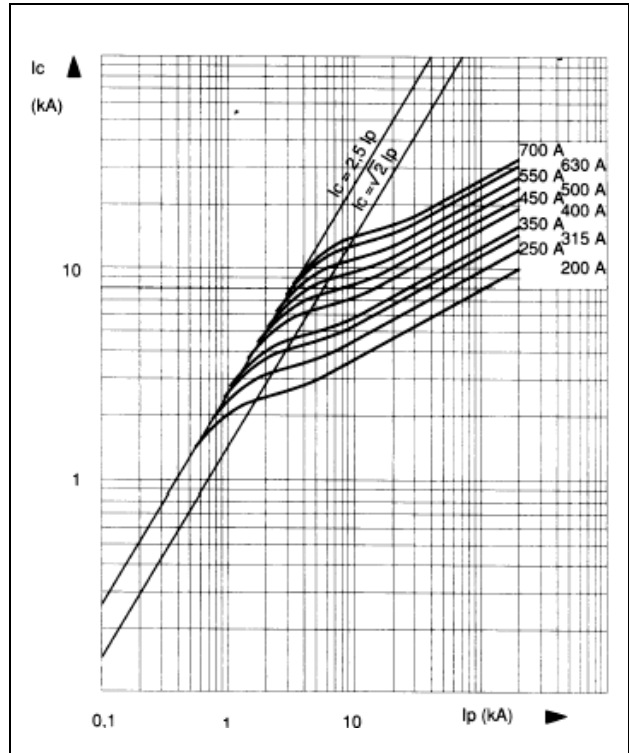

Size 2

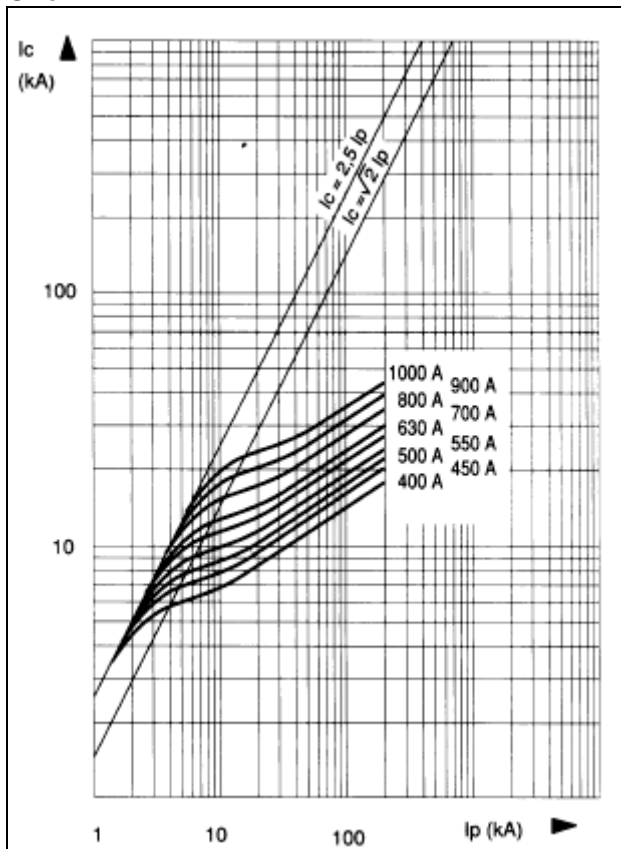

Size 3

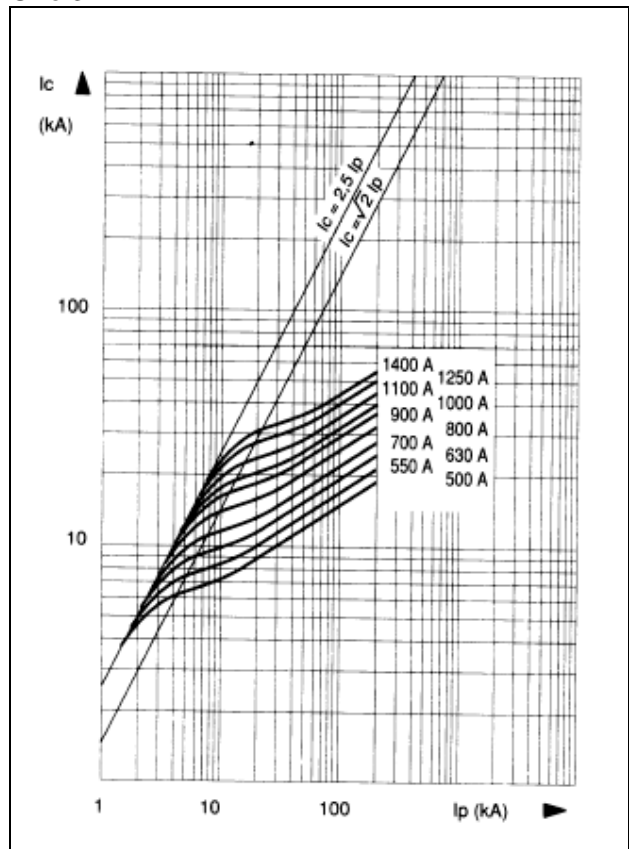

**Corrective Factor – Peak Arc Voltage:**

**I<sup>2</sup>t Multiplier Coefficient**

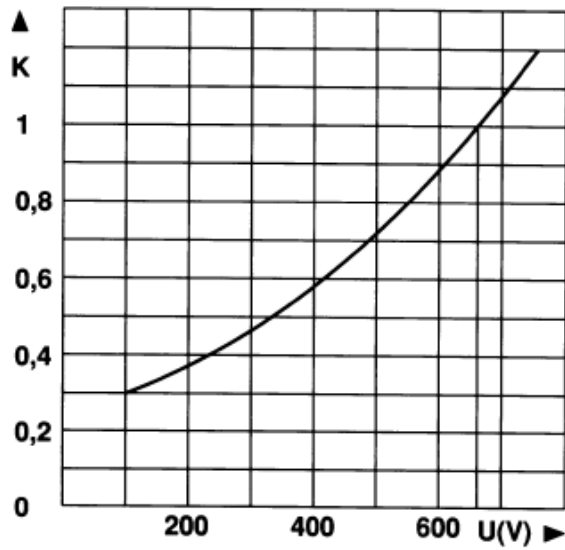

The above Mean curve shows variation of total clearing time ( $I^2t_i$ ) and total operating time  $T_t$  in accordance with working voltage U.

**Peak Arc Voltage**

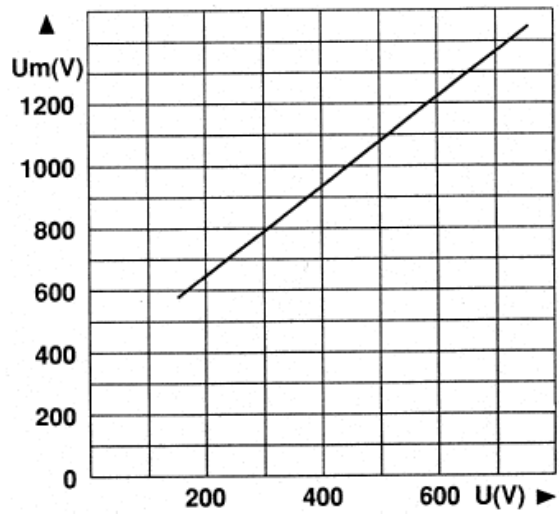

Curve indicating peak arc voltage  $U_m$  which may appear across fuse terminals as a function of working voltage U @  $\cos \varphi = 0.15$ .

**Dissipated Power**

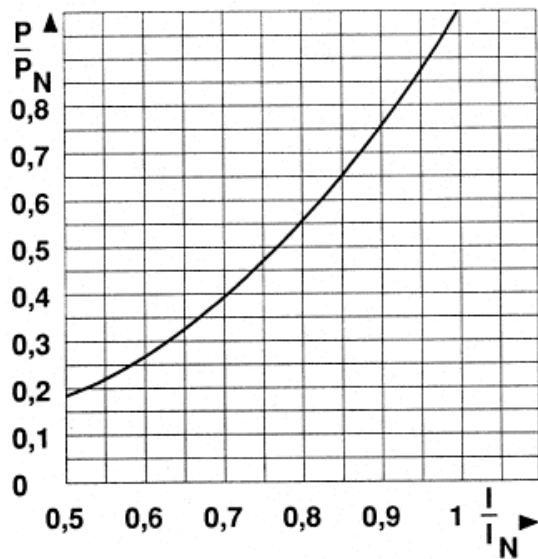

Curve enabling calculation of dissipated power P by a fuse rated  $I_N$ , as a function of the RMS current I, in multiples of  $I_N$  in a steady state.

**Outline Drawing & Ordering Information:**

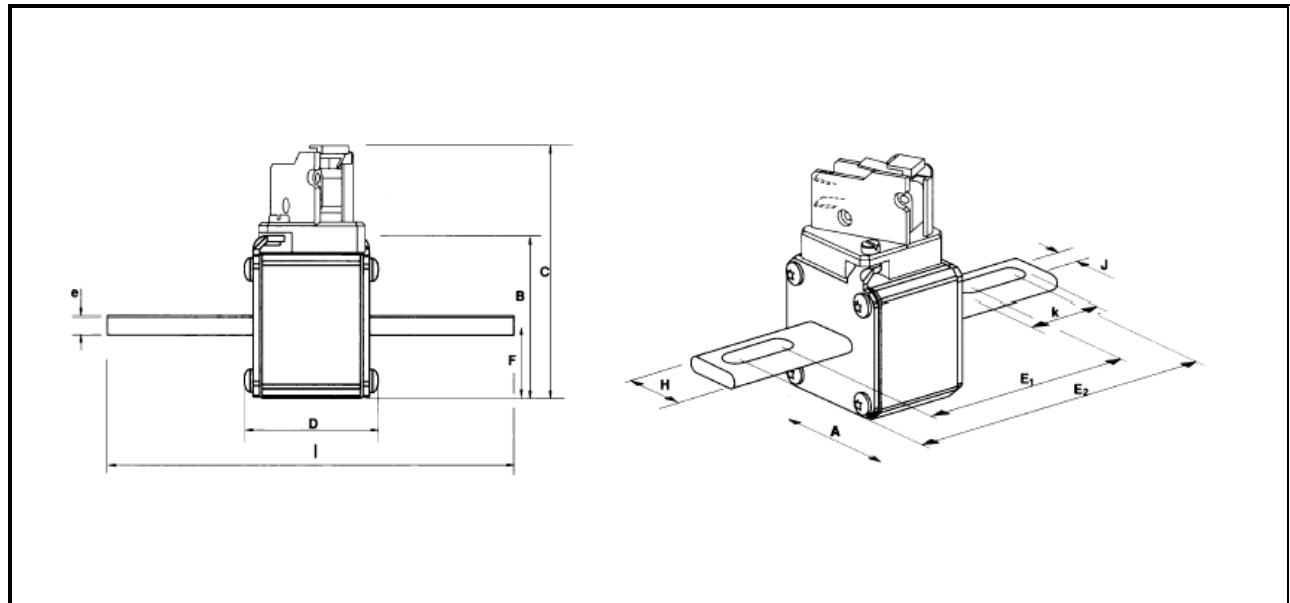

Dimensions (mm) (Imperial Measurements available upon request)

Size	A	B	C	D	E <sub>1</sub>	E <sub>2</sub>	F	H	J	K	L	E	Weight
0	40	46.5	82	47.5	87.6	126.6	21	25	105	30	148.5	6	290g
1	51	56.5	91	47.5	91.6	122.4	25.5	25	14.6	30	148.6	6	430g
2	60	65.5	100	47.5	94.2	129	30	32	14.6	32	153	6	590g / 660g
3	74.5	79.5	114	48.5	94.4	126.6	37.2	40	15.9	32	153	6	860g / 1070g

(\* ) size 2 from 900A and size 3 from 1250A

**ORDERING INFORMATION**

(Please quote code as below)

Voltage Rating (V)	Type	Size	Fixing	Current Rating Amps (A)	Indicator Type
700	US	0, 1, 2, or 3	D	0063 – 1600	B

Order code: eg. **070US3D0063B** = 700V, American Square Body Fuse with Long Blade, Size 3, 110mm fixing diameter, 63A with button indicator

**IXYS Semiconductor GmbH**  
 Edisonstraße 15  
 D-68623 Lampertheim  
 Tel: +49 6206 503-0  
 Fax: +49 6206 503-627  
 E-mail: [marcom@ixys.de](mailto:marcom@ixys.de)

**WESTCODE**  
 An IXYS Company

**Westcode Semiconductors Ltd**  
 Langley Park Way Langley Park  
 Chippenham Wiltshire SN15 1GE  
 Tel: +44 (0)1249 444524  
 Fax: +44 (0)1249 659448  
 E-mail: [WSL.sales@westcode.com](mailto:WSL.sales@westcode.com)

**IXYS Corporation**  
 3540 Bassett Street  
 Santa Clara CA 95054 USA  
 Tel: +1 (408) 982 0700  
 Fax: +1 (408) 496 0670  
 E-mail: [sales@ixys.com](mailto:sales@ixys.com)

[www.westcode.com](http://www.westcode.com)

[www.ixys.com](http://www.ixys.com)

**Westcode Semiconductors Inc**  
 3270 Cherry Avenue  
 Long Beach CA 90807 USA  
 Tel: +1 (562) 595 6971  
 Fax: +1 (562) 595 8182  
 E-mail: [WSI.sales@westcode.com](mailto:WSI.sales@westcode.com)

The information contained herein is confidential and is protected by Copyright. The information may not be used or disclosed except with the written permission of and in the manner permitted by the proprietors Westcode Semiconductors Ltd.

© Westcode Semiconductors Ltd.

In the interest of product improvement, Westcode reserves the right to change specifications at any time without prior notice.

## Ultra Rapid Semiconductor Protection Fuse

American Square Body Type Fuses











**American Long Blades**  
**Voltage Ratings 900V to 1300V**  
**Current Ratings 63A to 1800A**  
**Sizes 0, 1, 2, 3**



### **Key Features:**













- ❖ Exceptionally low  $I^2t$ , power losses
- ❖ Highly reliable low voltage indicator system
- ❖ Non Magnetic construction
- ❖ Conform to UL, CSA investigated, IEC, DIN and VDE standards
- ❖ Increased technical performance gives higher ratings and a reduction in volume and weight
- ❖ Microswitch system reference MS 7V 1-5

**Main Characteristics:**

Size	Voltage U <sub>N</sub> (V)	Ref:		Current rating I <sub>N</sub> (A)	Pre-arcing I <sup>2</sup> t @ 1 ms I <sup>2</sup> t <sub>p</sub> (kA <sup>2</sup> s)	Total Clearing I <sup>2</sup> t @ U <sub>N</sub> (kA <sup>2</sup> s)	Watt Losses		Tested Interrupting rating
							0.8I <sub>N</sub>	I <sub>N</sub>	
0	1300V	130US0D0063B		63	0.21	1.2	13	26	100kA @1300V
		130US0D0080B		80	0.47	2.7	13.5	27	
		130US0D0100B		100	0.83	4.8	15	30	
		130US0D0125B		125	1.3	7.5	19	38	
		130US0D0160B		160	2.55	15	22.5	45	
		130US0D0200B		200	4.7	27	28	56	
		130US0D0250B		250	9.6	55	30.5	61	
		130US0D0280B		280	14	82	32	64	
		130US0D0315B		315	20	115	36	72	
1200V	120US0D0350B		350	28	158	37.5	75	150kA @ 1200V	











Notes: Minimum operating voltage for integrated trip indicator = 20V

Microswitch reference : MS 7V 1-5











Size	Voltage U <sub>N</sub> (V)	Ref:		Current rating I <sub>N</sub> (A)	Pre-arcing I <sup>2</sup> t @ 1 ms I <sup>2</sup> t <sub>p</sub> (kA <sup>2</sup> s)	Total Clearing I <sup>2</sup> t @ U <sub>N</sub> (kA <sup>2</sup> s)	Watt Losses		Tested Interrupting rating
							0.8I <sub>N</sub>	I <sub>N</sub>	
1	1300V	130US1D0160B		160	2.6	15	23	46	100kA @ 1300V
		130US1D0200B		200	4.7	27	27	54	
		130US1D0250B		250	8.9	51	30.5	61	
		130US1D0280B		280	12	68	35	70	
		130US1D0315B		315	16	92	38	76	
		130US1D0350B		350	22	127	40	80	
		130US1D0400B		400	38	220	40	80	
		130US1D0450B		450	47	270	47.5	95	
		130US1D0500B		500	68	390	50	100	
	1200V	120US1D0550B		550	84	485	56	112	150kA @ 1200V
	120US1D0630B		630	125	725	60	120		

Notes: Minimum operating voltage for integrated trip indicator = 20V

Microswitch reference : MS 7V 1-5

Size	Voltage U <sub>N</sub> (V)	Ref:		Current rating I <sub>N</sub> (A)	Pre-arcing I <sup>2</sup> t @ 1 ms I <sup>2</sup> t <sub>p</sub> (kA <sup>2</sup> s)	Total Clearing I <sup>2</sup> t @ U <sub>N</sub> (kA <sup>2</sup> s)	Watt Losses 0.8I <sub>N</sub> I <sub>N</sub>		Tested Interrupting rating
2	1300V	130US2D0280B		280	10	60	36	72	100kA @1300V
		130US2D0315B		315	15	87	38	76	
		130US2D0350B		350	21	120	38	77	
		130US2D0400B		400	32.5	190	40	80	
		130US2D0450B		450	44	255	44.5	89	
		130US2D0500B		500	57	330	49	98	
	130US2D0550B		550	68	390	60	120		
	1200V	120US2D0630B		630	105	610	62.5	125	150kA @ 1200V
	1100V	110US2D0700B		700	145	815	70	140	150Ka @ 1100V
110US2D0800B			800	215	1240	73	146		

Notes: Minimum operating voltage for integrated trip indicator = 20V Micro switch reference : MS 7V 1-5

Size	Voltage U <sub>N</sub> (V)	Ref:		Current rating I <sub>N</sub> (A)	Pre-arcing I <sup>2</sup> t @ 1 ms I <sup>2</sup> t <sub>p</sub> (kA <sup>2</sup> s)	Total Clearing I <sup>2</sup> t @ U <sub>N</sub> (kA <sup>2</sup> s)	Watt Losses 0.8I <sub>N</sub> I <sub>N</sub>		Tested Interrupting rating
3	1300V	130US3D0315B		315	12	68	42	84	100kA @ 1300V
		130US3D0350B		350	17	100	43	86	
		130US3D0400B		400	25	145	46.5	93	
		130US3D0450B		450	35.5	205	50	100	
		130US3D0500B		500	44	255	56	112	
		130US3D0550B		550	57	330	60	120	
		130US3D0630B		630	84	485	66	132	
	1200V	120US3D0800B		800	190	1090	74	148	150kA @ 1200V
	1100V	110US3D0900B		900	250	1440	85	170	150kA @ 1100V
	900V	100US3D1000B		1000	370	2130	87	168	150kA @ 900V

Notes: Minimum operating voltage for integrated trip indicator = 20V  
Micro switch reference : MS 7V 1-5

**Electrical Characteristics:**

**Times vs current characteristics**

The curves shown on page 4 indicate the pre-arcing time for each rated current as a function of RMS value of pre-arcing current I:

- Tolerances on this current ± 8%
- Beyond 30 sec, small overloads must be eliminated by another device.
- 

Curve CC' represents the maximum times taken by the associated device to clear small overloads; only its horizontal line is represented.

Its oblique line must be plotted according to sketch in top right corner:

- The intersection of the fuse and CC' curves indicates the minimum breaking current I<sub>pm</sub> of the fuse.



Size 0

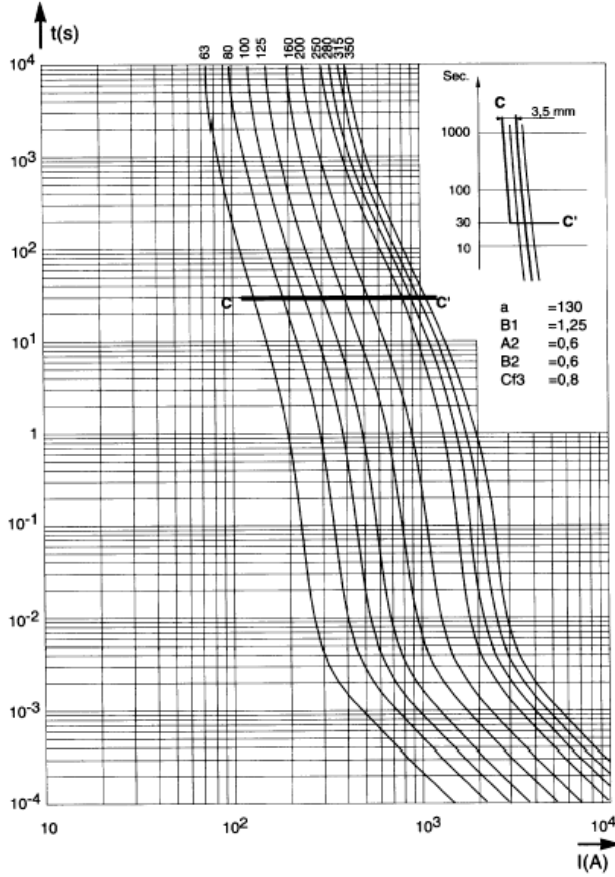

Size 1

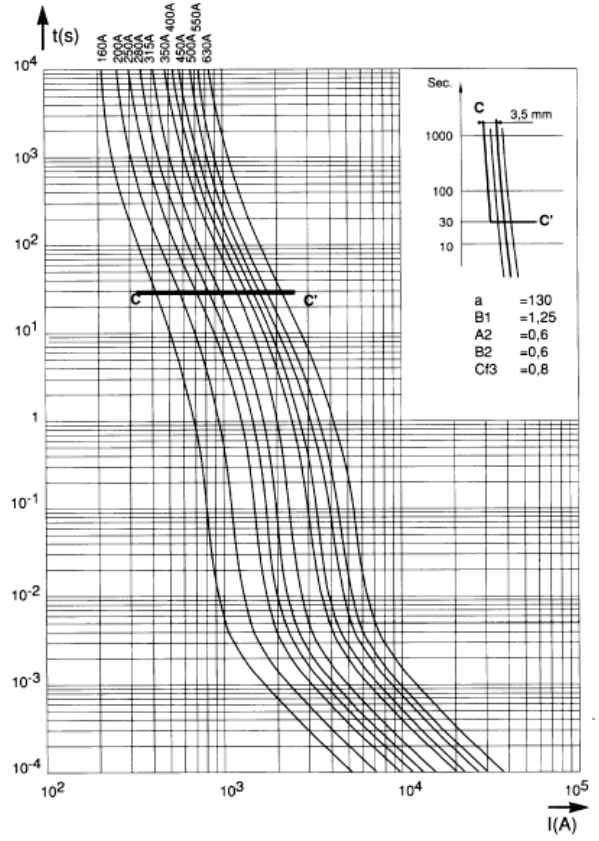

Size 2

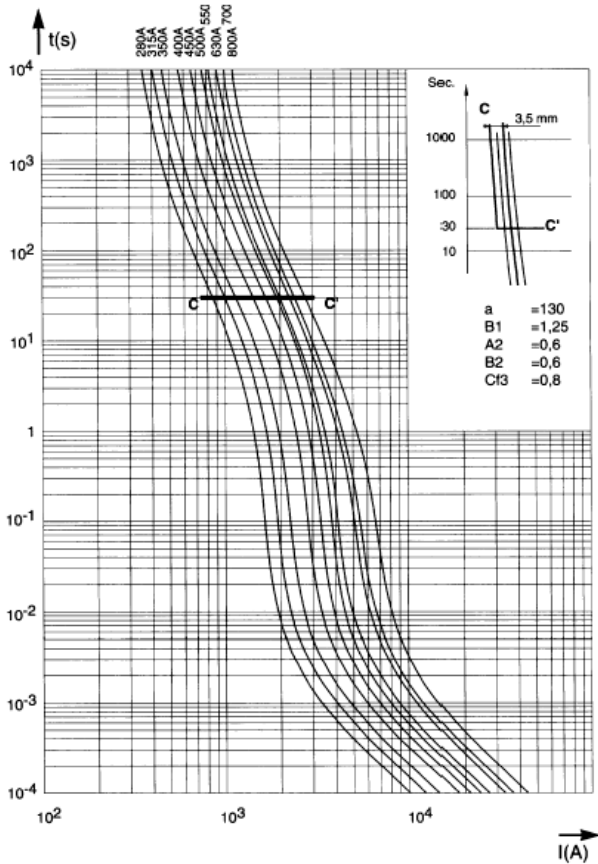

Size 3

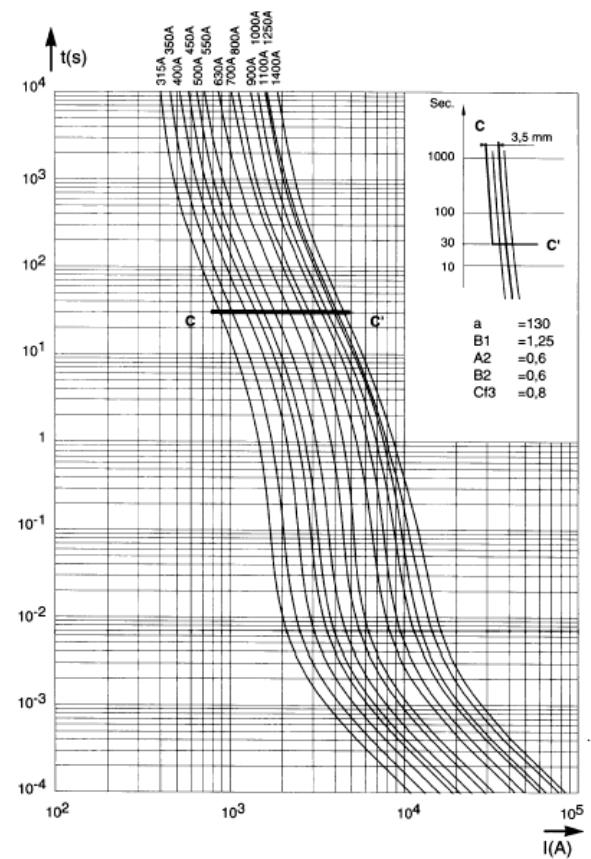

**Total clearing I<sup>2</sup>T:**

The horizontal curves given below indicate the maximum values of total operating I<sup>2</sup>t (I<sup>2</sup>t<sub>t</sub>) as a function of prospective current I<sub>p</sub> @ 1000V or 850V, cosφ = 0.15.

Oblique lines indicate the corresponding total operating time T<sub>t</sub>, with pre-arcing time in brackets.

**Size 0**

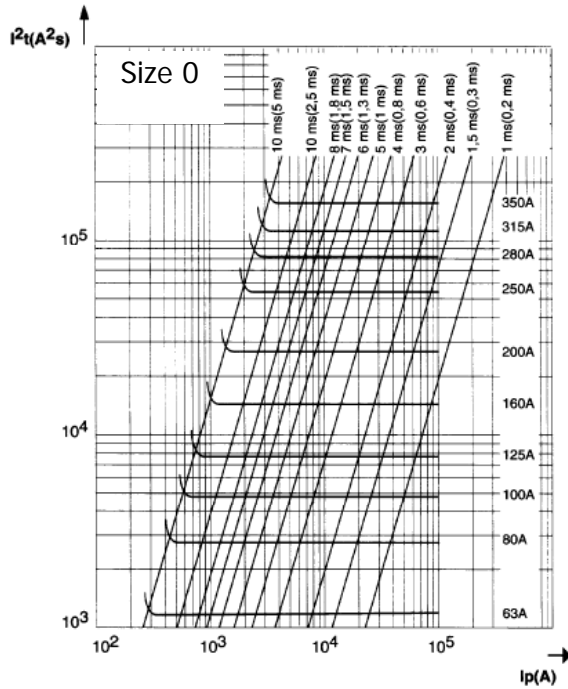

**Size 1**

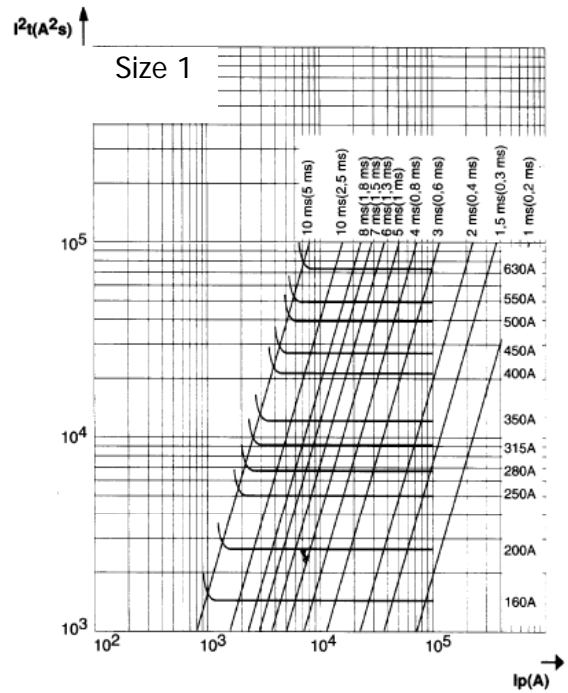

**Size 2 – Incorrect curve refer to factory**

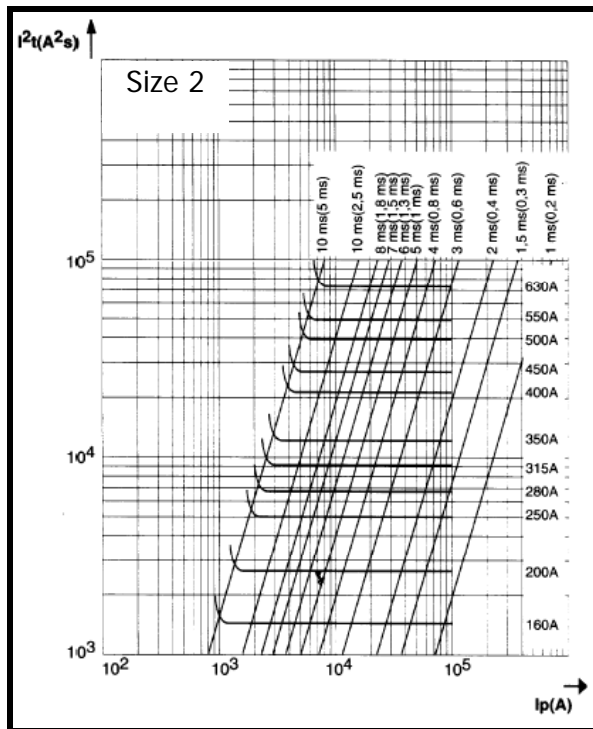

**Size 3**

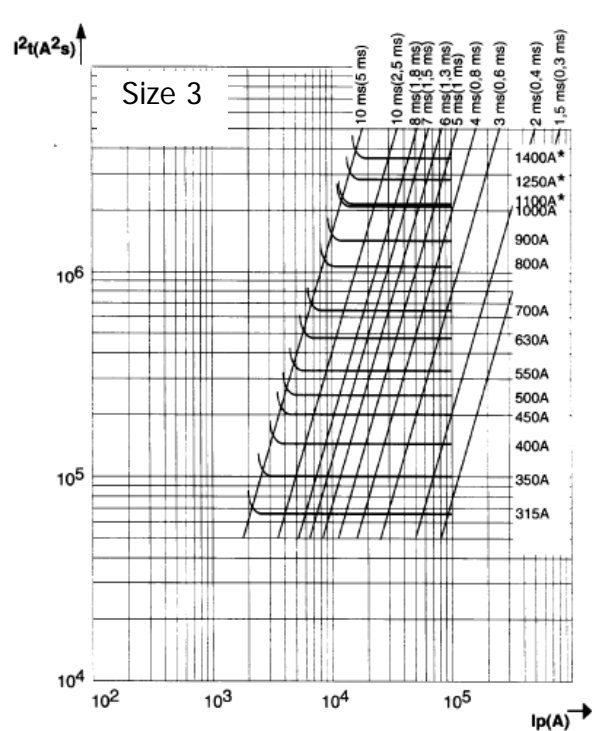

**Cut off Characteristics:**

The curves below indicate, for each rated current, the peak value  $I_c$  that the current may reach as a function of the prospective fault current  $I_p$ .

**Size 0**

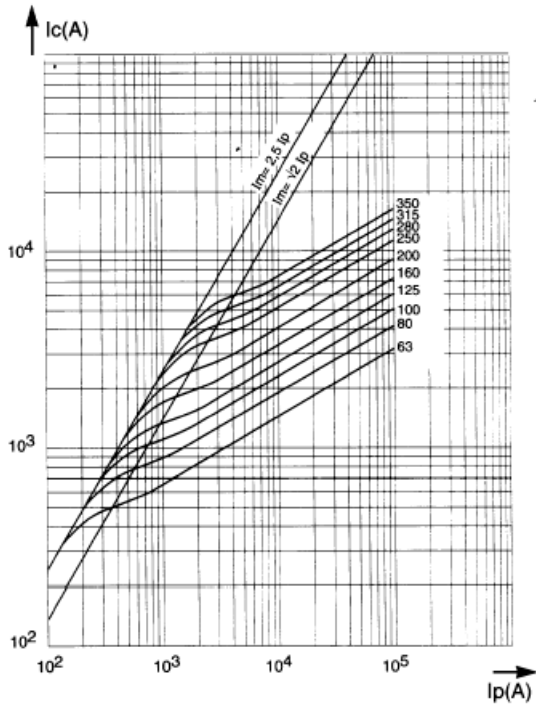

**Size 1**

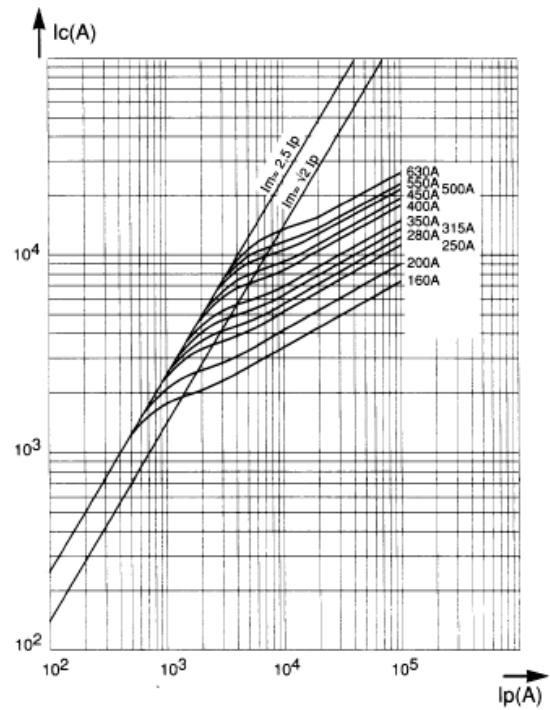

**Size 2**

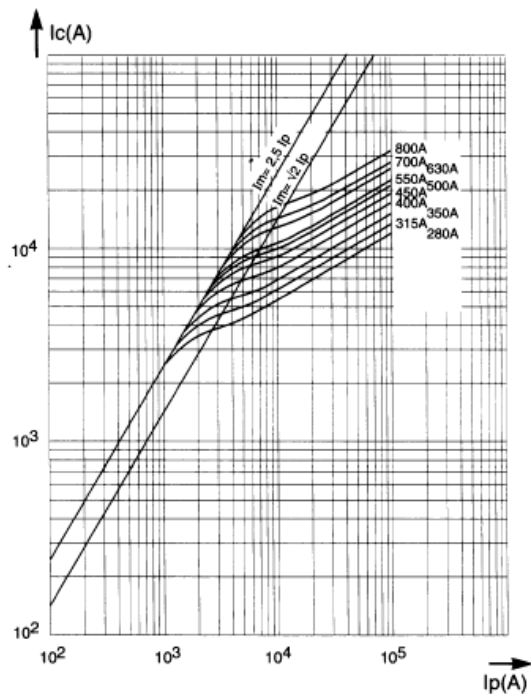

**Size 3**

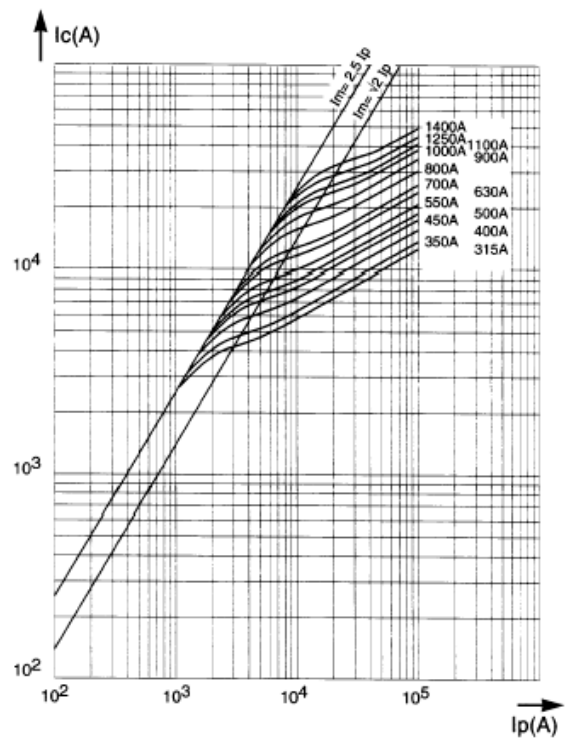

**Corrective Factor – Peak Arc Voltage:**

**Multiplier Coefficient:**

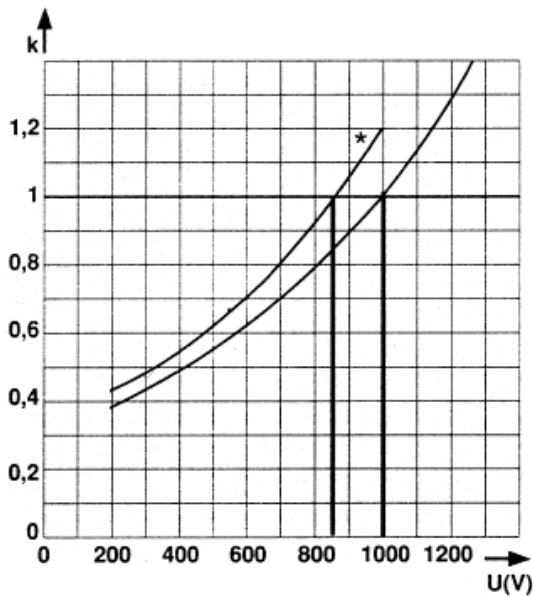

**Arc Voltage:**

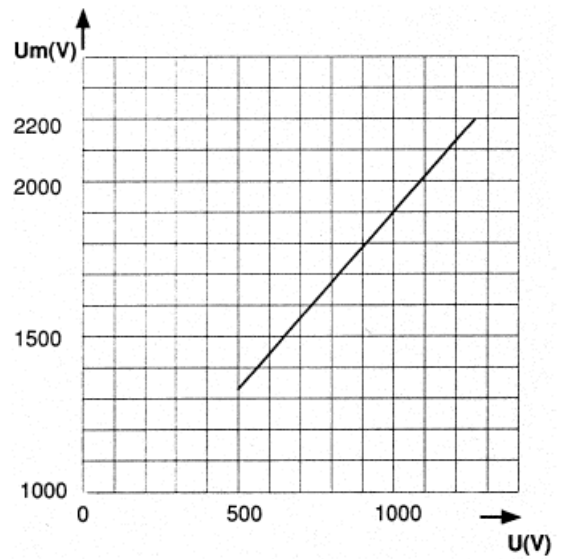

The above Mean curve shows variation of total  $I^2t$  ( $I^2t_t$ ) and total operating time  $T_t$  in accordance with working voltage  $U$ .

Curve indicating peak arc voltage  $U_m$  which may appear across fuse terminals as a function of working voltage  $U$  @  $\cos \varphi = 0.15$

**Dissipated Power:**

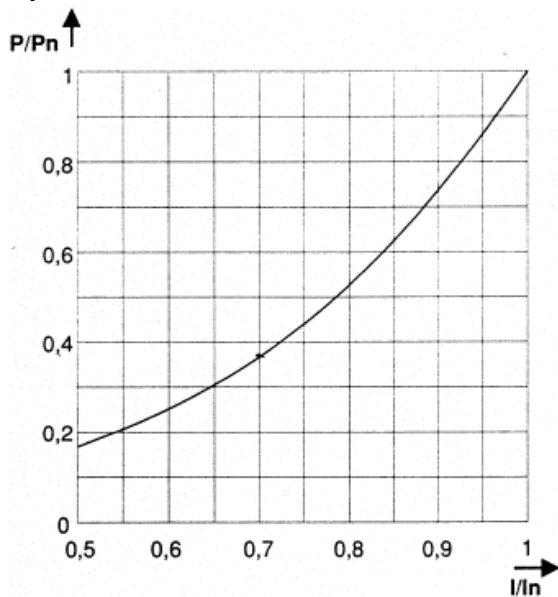

Curve enabling calculation of dissipated power  $P$  by a fuse rated  $I_N$ , as a function of the RMS current  $I$ , in multiples of  $I_N$ , in a steady state.

**Outline Drawing & Ordering Information**

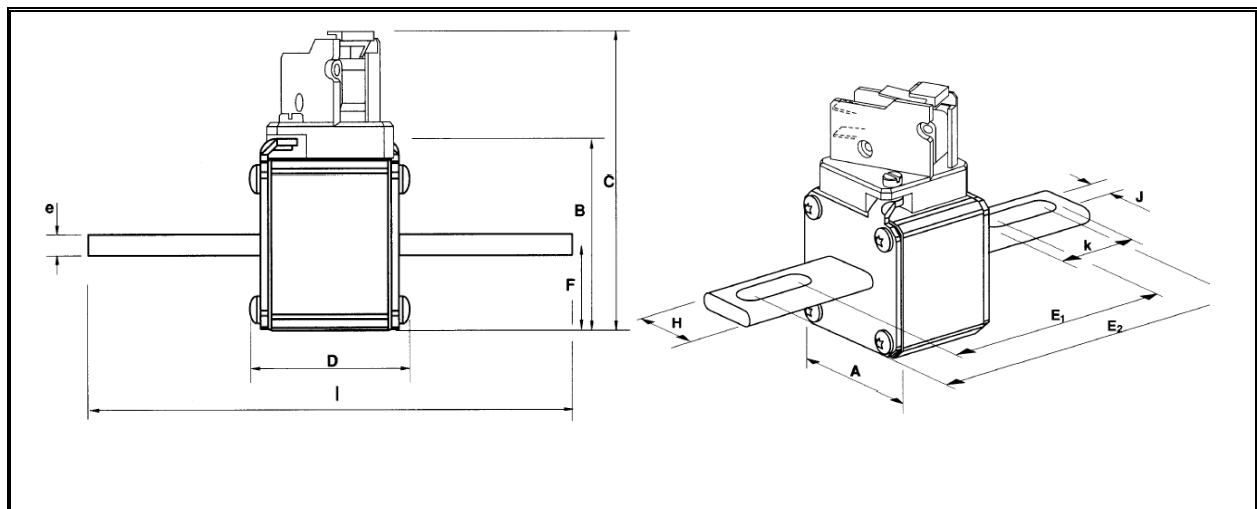

**Dimensions (mm) (Imperial measurements available upon request)**

Size	A	B	C	D	E <sub>1</sub>	E <sub>2</sub>	F	H	J	K	L	e	Weight
0	40	46.5	82	71	91.4	130.4	21	25	10.5	30	152.4	6	380g
1	51	56.5	91	71	91.4	130.4	25.5	25	10.5	30	152.4	6	630g
2	60	65.5	100	71	97.6	132.4	30	32	14.6	32	157.4	6	860g
3	74.5	79.5	114	72	98.8	131.4	37.2	40	15.9	32	157.4	6	900g / 1250g

(\* ) size 2 from 900A and size 3 from 1250A

**ORDERING INFORMATION**

(Please quote code as below)

Voltage Rating (V)	Type	Size	Fixing	Current Rating (A)	Indicator
900 – 1250	US	0, 1, 2, 3	D	0063 – 1800	B

Order code: e.g. **130US2D0550B** = 1300V, American Square Body with Long Blades, Size 2, 110mm, 550A with button indicator

**IXYS Semiconductor GmbH**  
 Edisonstraße 15  
 D-68623 Lampertheim  
 Tel: +49 6206 503-0  
 Fax: +49 6206 503-627  
 E-mail: [marcom@ixys.de](mailto:marcom@ixys.de)



An IXYS Company

**Westcode Semiconductors Ltd**  
 Langley Park Way Langley Park  
 Chippenham Wiltshire SN15 1GE  
 Tel: +44 (0)1249 444524  
 Fax: +44 (0)1249 659448  
 E-mail: [WSL.sales@westcode.com](mailto:WSL.sales@westcode.com)

**IXYS Corporation**  
 3540 Bassett Street  
 Santa Clara CA 95054 USA  
 Tel: +1 (408) 982 0700  
 Fax: +1 (408) 496 0670  
 E-mail: [sales@ixys.com](mailto:sales@ixys.com)

[www.westcode.com](http://www.westcode.com)

[www.ixys.com](http://www.ixys.com)

**Westcode Semiconductors Inc**  
 3270 Cherry Avenue  
 Long Beach CA 90807 USA  
 Tel: +1 (562) 595 6971  
 Fax: +1 (562) 595 8182  
 E-mail: [WSI.sales@westcode.com](mailto:WSI.sales@westcode.com)

The information contained herein is confidential and is protected by Copyright. The information may not be used or disclosed except with the written permission of and in the manner permitted by the proprietors Westcode Semiconductors Ltd.

© Westcode Semiconductors Ltd.

In the interest of product improvement, Westcode reserves the right to change specifications at any time without prior notice.

## Ultra Rapid Semiconductor Protection Fuse

### BS 88 Round Body Fuses – 250V

**British Standard  
Voltage Rating 250V  
Current Ratings from 5A to 180A  
aR Characteristics  
Sizes 10x28 and 17x27**



#### **Key Features:**

- ❖ Extremely high interrupting rating fuses for the protection of power semiconductors as per IEC Standard 60269.1 and 4.
- ❖ 250V voltage rating complying with IEC 33
- ❖ Non Magnetic construction
- ❖ gR Characteristics for ratings 5A to 32A (LCW range) comply with VDE 636-23 and IEC 60269.4
- ❖ 17 x 27 models are UL recognised
- ❖ aR Characteristics with current ratings from 5A to 180A (LEW or LEWI range) comply with VDE 636-23 and IEC 60269.4
- ❖ Available with or without separate trip indicator BS88-4
- ❖ Microswitch reference: MC 6.3 GR 2-5 N

**Main Characteristics:**

**LCW : 10x28 without trip indicator**

Voltage U <sub>N</sub> (V)	Size	Ref:	Micro Switch	UL	Current rating I <sub>N</sub> (A)	Pre-arcing I <sup>2</sup> t @ 1 ms I <sup>2</sup> t <sub>p</sub> (A <sup>2</sup> s)	Total Clearing I <sup>2</sup> t @ U <sub>N</sub> (A <sup>2</sup> s)		Power Losses @		Tested Interrupting rating
							I <sub>p</sub> ≤ 30I <sub>N</sub>	I <sub>p</sub> > 30I <sub>N</sub>	0.8 I <sub>N</sub>	I <sub>N</sub>	
250	10x28	5LCW	N	N	5	1.3	10	11	0.6	1.0	160kA @ 250V
		6LCW	N	N	6	1.8	13	15	0.7	1.2	
		10LCW	N	N	10	2.4	18	20	1.2	2.1	
		12LCW	N	N	12	4.3	28	33	1.6	2.8	
		16LCW	N	N	15	6.7	41	48	2.0	3.5	
		20LCW	N	N	20	15.0	85	100	2.2	4.0	
		25LCW	N	N	25	27.0	135	160	2.6	4.7	
		32LCW	N	N	32	53.0	240	280	3.0	5.4	

**LEW : 17x27 without trip indicator**

Voltage U <sub>N</sub> (V)	Size	Ref:	Micro Switch	UL	Current rating I <sub>N</sub> (A)	Pre-arcing I <sup>2</sup> t @ 1 ms I <sup>2</sup> t <sub>p</sub> (A <sup>2</sup> s)	Total Clearing I <sup>2</sup> t @ U <sub>N</sub> (A <sup>2</sup> s)		Power Losses @		Tested Interrupting rating
							I <sub>p</sub> ≤ 30I <sub>N</sub>	I <sub>p</sub> > 30I <sub>N</sub>	0.56 I <sub>N</sub>	I <sub>N</sub>	
250	17x27	7LEW	N	<b>RU</b>	7	1.3	8.5	9.8	0.56	1.0	160 kA @ 250V
		10LEW	N	<b>RU</b>	10	4.5	21	23.8	0.84	1.5	
		12LEW	N	<b>RU</b>	12	5.9	27	31	1.1	2.0	
		16LEW	N	<b>RU</b>	16	11.2	50	59	1.7	3.0	
		20LEW	N	<b>RU</b>	20	15.6	80	100	2.2	3.9	
		25LEW	N	<b>RU</b>	25	30.0	130	160	2.7	4.8	
		32LEW	N	<b>RU</b>	30	45.0	195	235	3.2	5.6	
		35LEW	N	<b>RU</b>	35	63.0	270	330	3.7	6.5	
		40LEW	N	<b>RU</b>	50	180.0	790	940	4.9	8.8	
		50LEW	N	<b>RU</b>	60	250.0	1100	1310	5.8	10.4	
		63LEW	N	<b>RU</b>	75	380.0	1670	1990	7.2	13.6	
		80LEW	N	<b>RU</b>	80	480.0	2100	2530	7.25	13.7	
		100LEW	N	<b>RU</b>	100	730.0	3350	4060	6.5	11.5	
		125LEW	N	<b>RU</b>	125	850.0	5720	6920	6.7	12.3	
		150LEW	N	<b>RU</b>	150	1250.0	7930	9590	7.4	13.6	
		160LEW	N	<b>RU</b>	160	1730.0	9600	11700	8.8	15.6	
180LEW	N	<b>RU</b>	180	2090.0	14500	17500	9.5	17.0			

**LEWI : 17x27 with separate trip indicator**

Voltage U <sub>N</sub> (V)	Size	Ref:	Micro Switch	UL	Current rating I <sub>N</sub> (A)	Pre-arcing I <sup>2</sup> t @ 1 ms I <sup>2</sup> t <sub>a</sub> (A <sup>2</sup> s)	Total Clearing I <sup>2</sup> t @ U <sub>N</sub> (A <sup>2</sup> s)		Power Losses @		Tested Interrupting rating
250	17x27	7LEWI	Y		7	1.3	8.5	9.8	0.56	1.0	160 kA @ 250V
		10LEWI	Y		10	4.5	21	23.8	0.84	1.5	
		12LEWI	Y		12	5.9	27	31	1.1	2.0	
		16LEWI	Y		16	11.2	50	59	1.7	3.0	
		20LEWI	Y		20	15.6	80	100	2.2	3.9	
		25LEWI	Y		25	30.0	130	160	2.7	4.8	
		32LEWI	Y		30	45.0	195	235	3.2	5.6	
		35LEWI	Y		35	63.0	270	330	3.7	6.5	
		40LEWI	Y		50	180.0	790	940	4.9	8.8	
		50LEWI	Y		60	250.0	1100	1310	5.8	10.4	
		63LEWI	Y		75	380.0	1670	1990	7.2	13.6	
		80LEWI	Y		80	480.0	2100	2530	7.25	13.7	
		100LEWI	Y		100	730.0	3350	4060	6.5	11.5	
		125LEWI	Y		125	850.0	5720	6920	6.7	12.3	
		150LEWI	Y		150	1250.0	7930	9590	7.4	13.6	
		160LEWI	Y		160	1730.0	9600	11700	8.8	15.6	
180LEWI	Y		180	2090.0	14500	17500	9.5	17.0			

Notes: Minimum operating voltage for integrated trip indicator = 20V  
 Microswitch reference: MC 6.3 GR 2-5 N



**Electrical Characteristics:**

**Times vs current characteristics**

These curves indicate, for each rated current, the pre-arcing

Tolerance for the mean pre-arcing current  $\pm 10\%$

**LCW : Size 10x28**

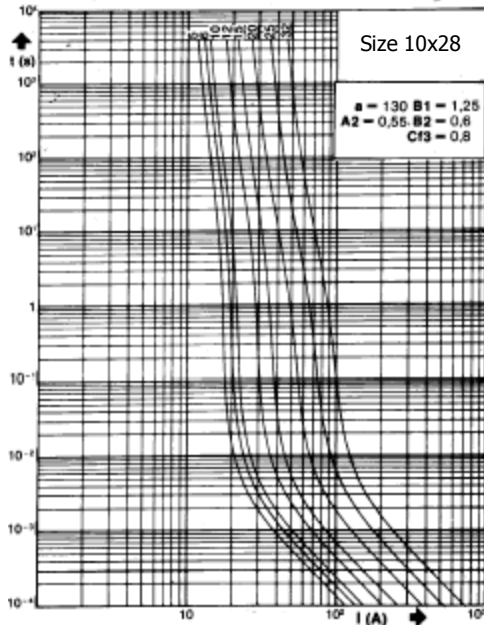

**LEW (LEWI with indicator) : Size 17x27 I ≤ 80 LEW (I**

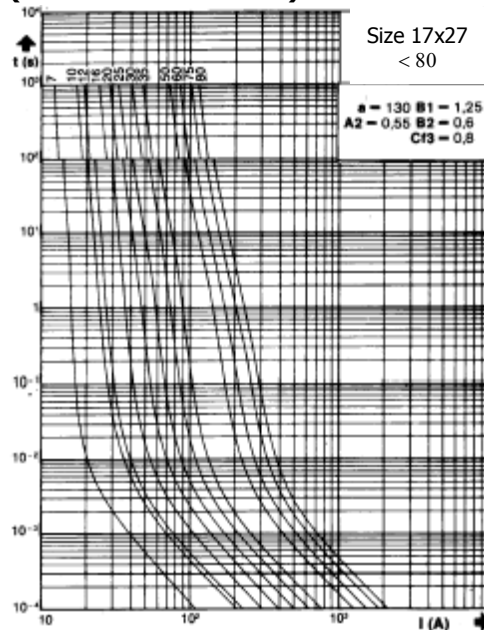

These curves indicate, for each rated current, the pre-arcing time vs the RMS pre-arcing current.

Tolerance for the mean pre-arcing current  $\pm 10\%$

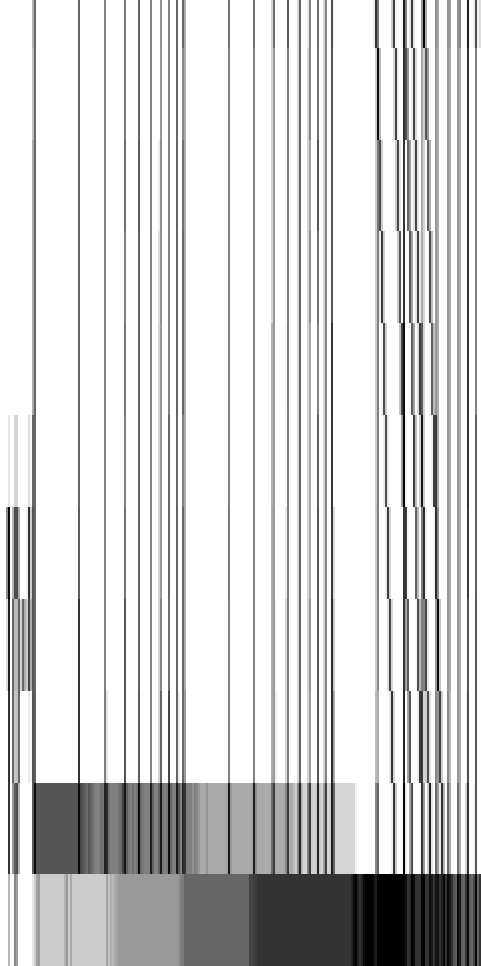

**100**

Size 17x27  
>100

**Corrective Factor**

LCW : Size 10x28

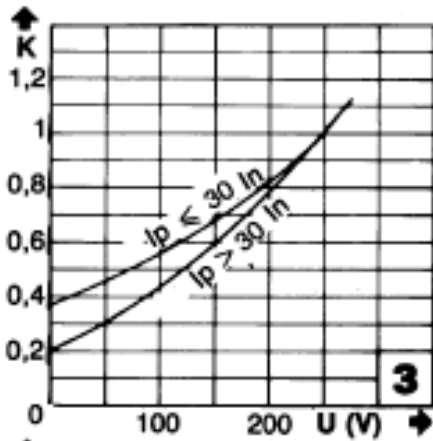

**Peak Arc Voltage:**

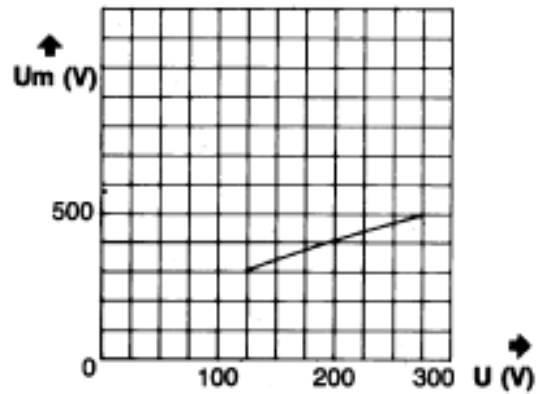

LEW & LEWI : Size 17x27 I ≤ 80

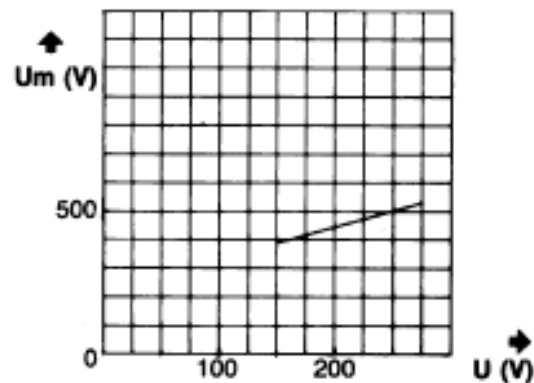
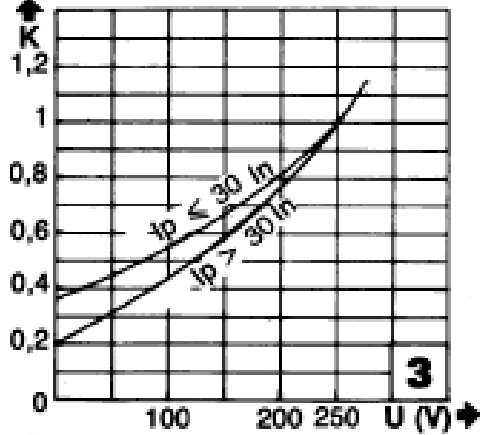

LEW & LEWI : Size 17x27 I ≥ 100

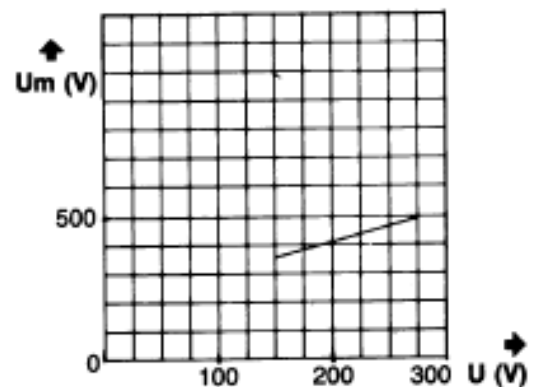
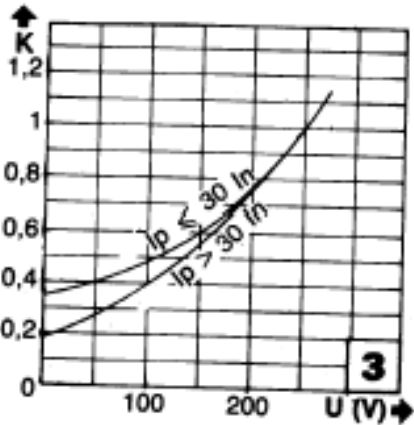

**Corrective factor :**

The mean curves show the variance of the total clearing time ( $I^2t$ ) and the total clearing duration  $t_t$  as a function of operating voltage  $U$ .

**Peak arc voltage :**

This curve shows the peak value  $U_m$  of the arc voltage which appears across the fuse link as a function of the operating voltage  $U$  @  $\cos \varphi = 0.15$ .

**Outline Drawing & Ordering Information:**

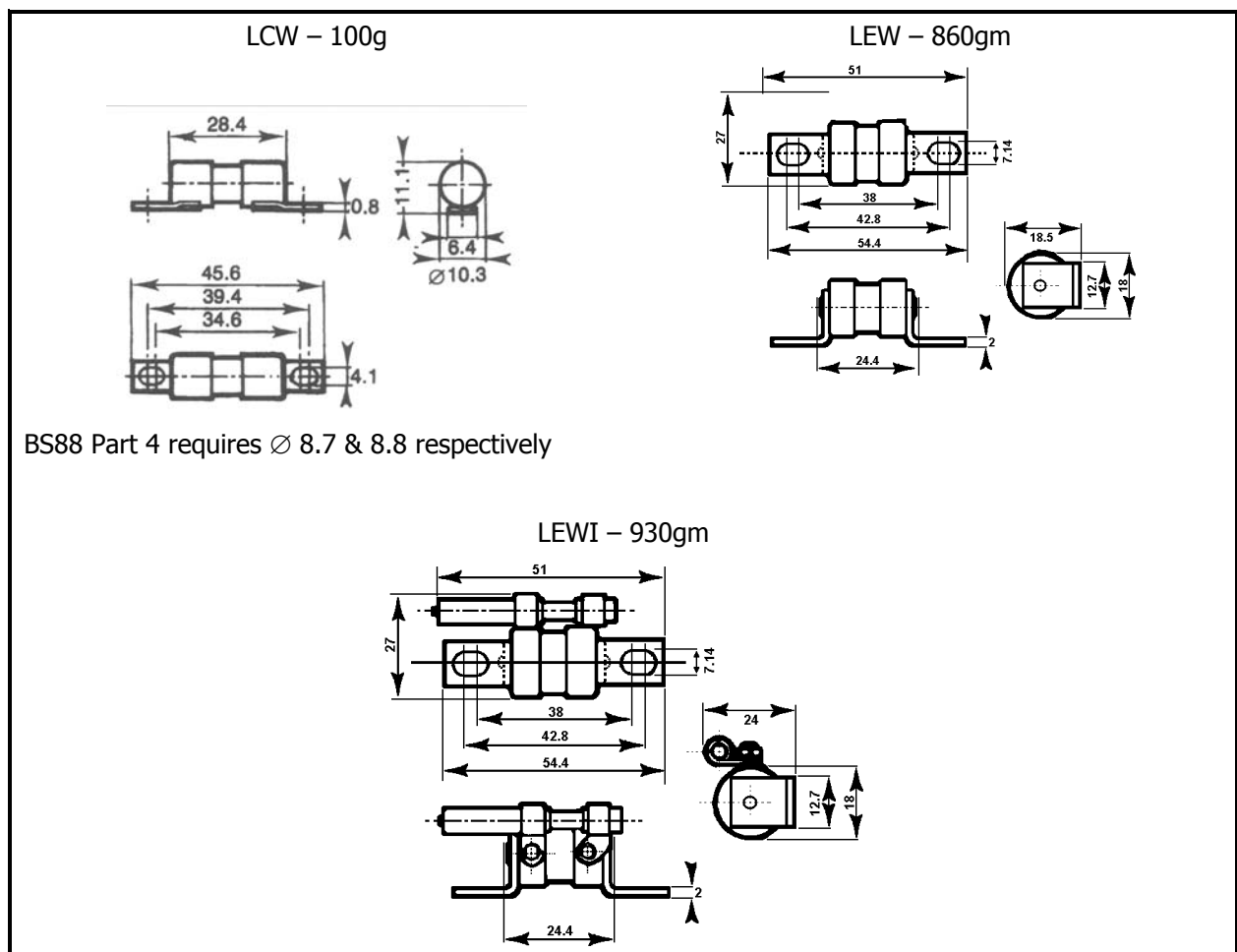

BS88 Part 4 requires Ø 8.7 & 8.8 respectively

ORDERING INFORMATION <span style="float: right;">(Please quote code as below)</span>				
Voltage	Size	Current Rating (A)	Ref.	Trip Indicator
250V	10x28 or 17x27	5 to 180	LCW or LEW	I

Order code: e.g. **180LEWI** = 250V size 17x27, 180amp fuse with trip indicator

**IXYS Semiconductor GmbH**  
 Edisonstraße 15  
 D-68623 Lampertheim  
 Tel: +49 6206 503-0  
 Fax: +49 6206 503-627  
 E-mail: [marcom@ixys.de](mailto:marcom@ixys.de)

**IXYS Corporation**  
 3540 Bassett Street  
 Santa Clara CA 95054 USA  
 Tel: +1 (408) 982 0700  
 Fax: +1 (408) 496 0670  
 E-mail: [sales@ixys.com](mailto:sales@ixys.com)

**WESTCODE**

An IXYS Company

[www.westcode.com](http://www.westcode.com)  
[www.ixys.com](http://www.ixys.com)

**Westcode Semiconductors Ltd**  
 Langley Park Way Langley Park  
 Chippenham Wiltshire SN15 1GE  
 Tel: +44 (0)1249 444524  
 Fax: +44 (0)1249 659448  
 E-mail: [WSL.sales@westcode.com](mailto:WSL.sales@westcode.com)

**Westcode Semiconductors Inc**  
 3270 Cherry Avenue  
 Long Beach CA 90807 USA  
 Tel: +1 (562) 595 6971  
 Fax: +1 (562) 595 8182  
 E-mail: [WSL.sales@westcode.com](mailto:WSL.sales@westcode.com)

The information contained herein is confidential and is protected by Copyright. The information may not be used or disclosed except with the written permission of and in the manner permitted by the proprietors Westcode Semiconductors Ltd.

© Westcode Semiconductors Ltd.

In the interest of product improvement. Westcode reserves the right to change specifications at any time without prior notice.

# WESTCODE

An IXYS Company

Date:- 17 Mar, 2005

Data Sheet Issue:- 1

## Ultra Rapid Semiconductor Protection Fuse BS 88 Round Body Type Fuses 690V

**British Standard  
Voltage Rating - 690V  
Current Ratings from 160A to 710A  
aR Characteristics  
Sizes 36x55 and 2x36x55**



### **Key Features:**

- ❖ Extremely high interrupting rating fuses for the protection of power semiconductors as per IEC Standard 60269.1 and 4.
- ❖ 690V voltage rating complying with IEC 33
- ❖ Non Magnetic construction
- ❖ aR Characteristics with current ratings from 75 to 800A in accordance with VDE 636-23 and EC 60269.4
- ❖ The models available with or without separate or integrated trip indicator
- ❖ Microswitch reference MC 6,3 GR 2-5N

**Main Characteristics:**

**MW : 36x55 without trip indicator**

Size	Voltage U <sub>N</sub> (V)	Ref:	Micro Switch	Current rating I <sub>N</sub> (A)	Pre-arcing I <sup>2</sup> t @ 1 ms I <sup>2</sup> <sub>p</sub> (A <sup>2</sup> s)	Total Clearing I <sup>2</sup> t @ U <sub>N</sub> (A <sup>2</sup> s)		Power Losses @		Tested Interrupting rating
						I <sub>p</sub> ≤ 50I <sub>N</sub>	I <sub>p</sub> > 50 I <sub>N</sub>	0.8 I <sub>N</sub>	I <sub>N</sub>	
36x55	690V	160MW	N	150	2880	12600	14500	18.9	35.3	200kA @ 690V
		180MW	N	180	5350	22500	25500	19.1	35.7	
		200MW	N	200	9510	40000	46000	17.7	33.1	
		250MW	N	250	21400	97000	110000	18.7	34.5	
		280MW	N	280	29100	125000	145000	20.3	38	
		315MW	N	315	38100	157000	180000	22.7	42.6	
		355MW	N	355	48200	190000	215000	25.9	48.5	
		400MW	N	400	72000	265000	305000	26.7	50	

**MWI : 36x55 with separated trip indicator**

Size	Voltage U <sub>N</sub> (V)	Ref:	Micro Switch	Current rating I <sub>N</sub> (A)	Pre-arcing I <sup>2</sup> t @ 1 ms I <sup>2</sup> <sub>p</sub> (A <sup>2</sup> s)	Total Clearing I <sup>2</sup> t @ U <sub>N</sub> (A <sup>2</sup> s)		Power Losses @		Tested Interrupting rating
						I <sub>p</sub> ≤ 50I <sub>N</sub>	I <sub>p</sub> > 50 I <sub>N</sub>	0.8 I <sub>N</sub>	I <sub>N</sub>	
36x55	690V	160MWI	Y	150	2880	12600	14500	18.9	35.3	200kA @ 690V
		180MWI	Y	180	5350	22500	25500	19.1	35.7	
		200MWI	Y	200	9510	40000	46000	17.7	33.1	
		250MWI	Y	250	21400	97000	110000	18.7	34.5	
		280MWI	Y	280	29100	125000	145000	20.3	38	
		315MWI	Y	315	38100	157000	180000	22.7	42.6	
		355MWI	Y	355	48200	190000	215000	25.9	48.5	
		400MWI	Y	400	72000	265000	305000	26.7	50	

Notes: Minimum operating voltage for integrated trip indicator = 20V

Microswitch reference : MS 6.3 GR 2-5N

**MMW : 2x36x55 without trip indicator**

Size	Voltage U <sub>N</sub> (V)	Ref:	Micro Switch	Current rating I <sub>N</sub> (A)	Pre-arcing I <sup>2</sup> t @ 1 ms I <sup>2</sup> <sub>p</sub> (A <sup>2</sup> s)	Total Clearing I <sup>2</sup> t @ U <sub>N</sub> (A <sup>2</sup> s)		Power Losses @		Tested Interrupting rating
						I <sub>p</sub> ≤ 50I <sub>N</sub>	I <sub>p</sub> > 50 I <sub>N</sub>	0.8 I <sub>N</sub>	I <sub>N</sub>	
2x36x55	690V	180MMW	N	175	2880	13800	16000	24.7	47.6	200kA @ 690V
		200MMW	N	200	4700	24000	27000	18.4	33	
		235MMW	N	235	6920	34500	39000	21	37.6	
		315MMW	N	315	13700	60000	68000	31.5	59	
		355MMW	N	355	25200	106000	120000	33.1	62	
		400MMW	N	400	21200	100000	110000	34.8	62.3	
		450MMW	N	450	65600	300000	340000	34.6	63.8	
		500MMW	N	500	85600	390000	440000	37.4	69	
		630MMW	N	630	152000	630000	720000	45.4	85.2	
		710MMW	N	710	193000	760000	860000	51.8	97	

**MMWI : 2x36x55 with separated trip indicator**

Size	Voltage $U_N$ (V)	Ref:	Micro Switch	Current rating $I_N$ (A)	Pre-arcing $I^2t$ @ 1 ms $I^2t_p(A^2s)$	Total Clearing $I^2t$ @ $U_N$ (A <sup>2</sup> s)		Power Losses @		Tested Interrupting rating
						$I_p \leq 50 I_n$	$I_p > 50 I_n$	0.8 $I_n$	$I_n$	
2x36x55	690V	180MMWI	Y	175	2880	13800	16000	24.7	47.6	200kA @ 690V
		200MMWI	Y	200	4700	24000	27000	18.4	33	
		235MMWI	Y	235	6920	34500	39000	21	37.6	
		315MMWI	Y	315	13700	60000	68000	31.5	59	
		355MMWI	Y	355	25200	106000	120000	33.1	62	
		400MMWI	Y	400	21200	100000	110000	34.8	62.3	
		450MMWI	Y	450	65600	300000	340000	34.6	63.8	
		500MMWI	Y	500	85600	390000	440000	37.4	69	
		630MMWI	Y	630	152000	630000	720000	45.4	85.2	
710MMWI	Y	710	193000	760000	860000	51.8	97			

Notes: Minimum operating voltage for integrated trip indicator = 20V  
 Microswitch reference : MC 36 GR 2.5

**Electrical Characteristics:**

**Times vs current characteristics**

These curves indicate, for each rated current, the pre-arcing time vs. the RMS pre-arcing current.

Tolerance for the mean pre-arcing current  $\pm 10\%$

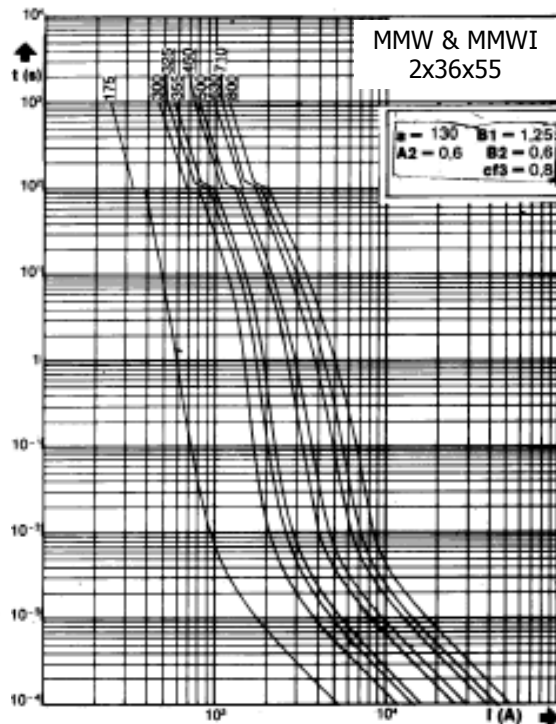
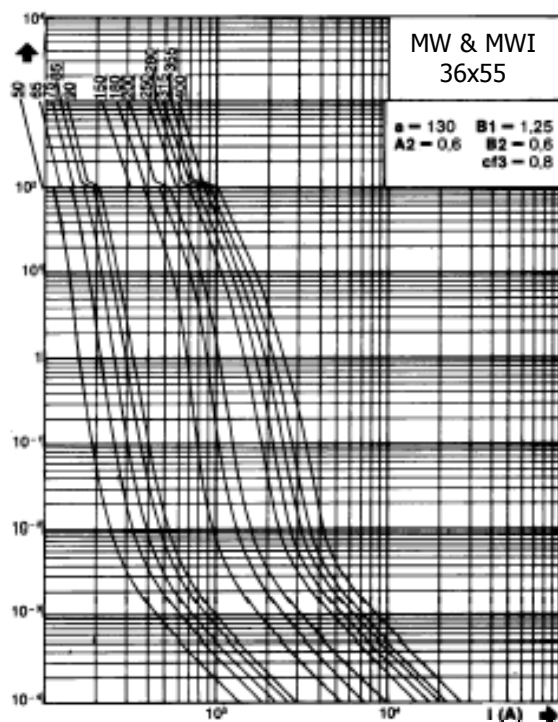

**Corrective Factor**

The mean curves show the variation of the total clearing time ( $I^2t_t$ ) and the total clearing duration  $t_t$  as a function of operating voltage U.

MW & MWI - size 36x55

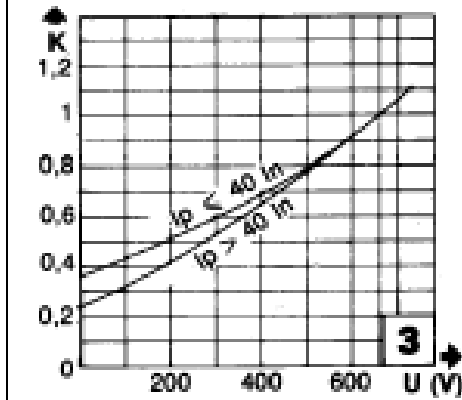

MMW & MMWI - size 2x36x55

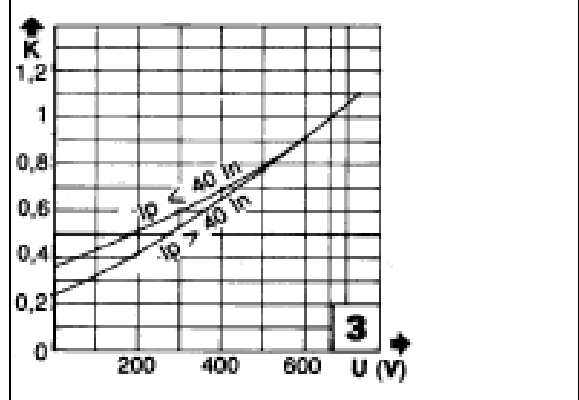

**Peak Arc Voltage**

This curve shows the peak value  $U_m$  of the arc voltage which appears across the fuse link as a function of the operating voltage U @  $\cos \varphi = 0.15$ .

MW & MWI - size 36x55

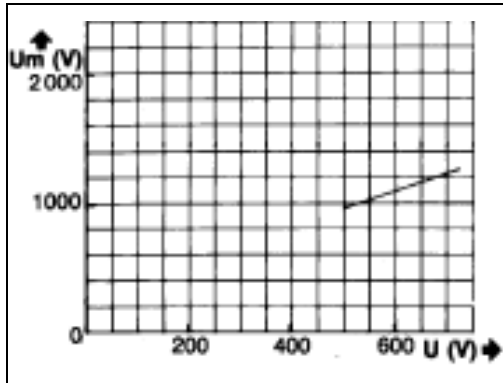

MMW & MMWI - size 2x36x55

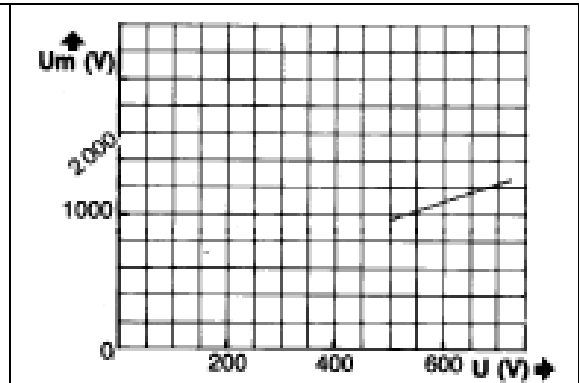

**Outline Drawings and Ordering Information:**

MW – 207gm

MWI – 207gm

MMW – 400gm

MMWI – 400gm

ORDERING INFORMATION				
(Please quote code as below)				
Style	Voltage	Current Rating (A)	Type	Indicator
BS 88 Round Body	660V	160 - 710	MW & MMW	I

Order code: e.g. **315MMWI** = BS 88 660V Round Body 315Amp fuse with Trip Indicator

**IXYS Semiconductor GmbH**  
Edisonstraße 15  
D-68623 Lampertheim  
Tel: +49 6206 503-0  
Fax: +49 6206 503-627  
E-mail: [marcom@ixys.de](mailto:marcom@ixys.de)

**IXYS Corporation**  
3540 Bassett Street  
Santa Clara CA 95054 USA  
Tel: +1 (408) 982 0700  
Fax: +1 (408) 496 0670  
E-mail: [sales@ixys.com](mailto:sales@ixys.com)

# WESTCODE

An IXYS Company

[www.westcode.com](http://www.westcode.com)  
[www.ixys.com](http://www.ixys.com)

**Westcode Semiconductors Ltd**  
Langley Park Way Langley Park  
Chippenham Wiltshire SN15 1GE  
Tel: +44 (0)1249 444524  
Fax: +44 (0)1249 659448  
E-mail: [WSL.sales@westcode.com](mailto:WSL.sales@westcode.com)

**Westcode Semiconductors Inc**  
3270 Cherry Avenue  
Long Beach CA 90807 USA  
Tel: +1 (562) 595 6971  
Fax: +1 (562) 595 8182  
E-mail: [WSI.sales@westcode.com](mailto:WSI.sales@westcode.com)

The information contained herein is confidential and is protected by Copyright. The information may not be used or disclosed except with the written permission of and in the manner permitted by the proprietors Westcode Semiconductors Ltd. © Westcode Semiconductors Ltd.

In the interest of product improvement, Westcode reserves the right to change specifications at any time without prior notice.



## Ultra Rapid Semiconductor Protection Fuse BS 88 Round Body Type Fuses

**British Standard BS88-4  
Voltage Rating 250V  
Current Ratings from 50A to 1050A  
gR and aR Characteristics  
Sizes 36x27 & 2x36x27**



### **Key Features:**

- ❖ Extremely high interrupting rating fuses for the protection of power semiconductors as per IEC Standard 60269.1 and 4.
- ❖ 250V voltage rating complying with IEC 33
- ❖ Non Magnetic construction
- ❖ gR Characteristics with current ratings from 50A to 350A (LMW & LMWI) and 300A to 700A (LMMW & LMMWI) in accordance with VDE 636-23 and IEC 60269.4 standards
- ❖ aR Characteristics with current ratings from 400 to 525A (LMW & LMWI) and 800A to 1050A (LMMW & LMMWI) in accordance with VDE 636-23 and IEC 60269.4 standards
- ❖ Models available with or without separate trip indicator
- ❖ Microswitch MC 6.3 GR 2-5N for fuses with separate trip indicator

**Main Characteristics:**

**LMW : Size 36x27 without indicator**

Voltage U <sub>N</sub> (V)	Size	Ref:	Micro Switch	Current rating I <sub>N</sub> (A)	Pre-arcing I <sup>2</sup> t @ 1 ms I <sup>2</sup> t <sub>p</sub> (A <sup>2</sup> s)	Total Clearing I <sup>2</sup> t @ U <sub>N</sub> (A <sup>2</sup> s)	Power Losses @		Tested Interrupting rating
							0.8 I <sub>N</sub>	I <sub>N</sub>	
250	36x27	50LMW	N	50	120	500	4.75	9.5	100kA @ 250V
		75LMW	N	75	330	1380	6.3	12.6	
		100LMW	N	100	745	3060	7.8	15.7	
		125LMW	N	125	1340	5500	9.1	18.2	
		160LMW	N	150	1930	7950	10.8	21.6	
		200LMW	N	200	4020	16400	13.5	27	
		250LMW	N	250	5350	30000	16.3	32.6	
		315LMW	N	300	7290	49600	18.6	37.2	
		355LMW	N	350	18000	74000	21	42.0	
		400LMW	N	400	25100	128000	23.4	46.7	
		450LMW	N	450	33500	170000	27.1	54.1	
		500LMW	N	500	43000	219000	30.4	60.8	
		525LMW	N	525	48200	245000	33.2	66.4	

**LMWI : Size 36x27 with separate trip indicator**

Voltage U <sub>N</sub> (V)	Size	Ref:	Micro Switch	Current rating I <sub>N</sub> (A)	Pre-arcing I <sup>2</sup> t @ 1 ms I <sup>2</sup> t <sub>p</sub> (A <sup>2</sup> s)	Total Clearing I <sup>2</sup> t @ U <sub>N</sub> (A <sup>2</sup> s)	Power Losses @		Tested Interrupting rating
							0.8 I <sub>N</sub>	I <sub>N</sub>	
250	36x27	50LMWI	Y	50	120	500	4.75	9.5	100kA @ 250V
		75LMWI	Y	75	330	1380	6.3	12.6	
		100LMWI	Y	100	745	3060	7.8	15.7	
		125LMWI	Y	125	1340	5500	9.1	18.2	
		160LMWI	Y	150	1930	7950	10.8	21.6	
		200LMWI	Y	200	4020	16400	13.5	27	
		250LMWI	Y	250	5350	30000	16.3	32.6	
		315LMWI	Y	300	7290	49600	18.6	37.2	
		355LMWI	Y	350	18000	74000	21	42.0	
		400LMWI	Y	400	25100	128000	23.4	46.7	
		450LMWI	Y	450	33500	170000	27.1	54.1	
		500LMWI	Y	500	43000	219000	30.4	60.8	
		525LMWI	Y	525	48200	245000	33.2	66.4	

Notes: Minimum operating voltage for integrated trip indicator = 20V  
Microswitch reference MC 6.3 GR 2-5N

**LMMW : Size 2x36x27 without trip indicator**

Voltage U <sub>N</sub> (V)	Size	Ref:	Micro Switch	Current rating I <sub>N</sub> (A)	Pre-arcing I <sup>2</sup> t @ 1 ms I <sup>2</sup> t <sub>p</sub> (A <sup>2</sup> s)	Total Clearing I <sup>2</sup> t @ U <sub>N</sub> (A <sup>2</sup> s)	Power Losses @		Tested Interrupting rating
250	2x36x27	315LMMW	N	300	7700	31800	21.6	43.2	100kA @ 250V
		355LMMW	N	350	11500	48700	24.3	48.6	
		400LMMW	N	400	16000	65600	27	54	
		500LMMW	N	500	29100	120000	32.6	65.2	
		630LMMW	N	600	48200	198500	37.2	74.4	
		710LMMW	N	700	72000	276000	42	84	
		800LMMW	N	800	100000	512000	46.7	93.4	
		900LMMW	N	900	134000	680000	54.1	108.2	
		1000LMMW	N	1000	172000	876000	60.8	121.6	
		1050LMMW	N	1050	193000	980000	66.4	132.8	

**LMMWI : Size 2x36x27 with trip indicator**

Voltage U <sub>N</sub> (V)	Size	Ref:	Micro Switch	Current rating I <sub>N</sub> (A)	Pre-arcing I <sup>2</sup> t @ 1 ms I <sup>2</sup> t <sub>p</sub> (A <sup>2</sup> s)	Total Clearing I <sup>2</sup> t @ U <sub>N</sub> (A <sup>2</sup> s)	Power Losses @		Tested Interrupting rating
250	2x36x27	315LMMWI	Y	300	7700	31800	21.6	43.2	100kA @ 250V
		355LMMWI	Y	350	11500	48700	24.3	48.6	
		400LMMWI	Y	400	16000	65600	27	54	
		500LMMWI	Y	500	29100	120000	32.6	65.2	
		630LMMWI	Y	600	48200	198500	37.2	74.4	
		710LMMWI	Y	700	72000	276000	42	84	
		800LMMWI	Y	800	100000	512000	46.7	93.4	
		900LMMWI	Y	900	134000	680000	54.1	108.2	
		1000LMMWI	Y	1000	172000	876000	60.8	121.6	
		1050LMMWI	y	1050	193000	980000	66.4	132.8	

Notes: Minimum operating voltage for integrated trip indicator = 20V  
Microswitch reference MC 6.3 GR 2-5N

**Electrical Characteristics:**

**Times vs current characteristics**

These curves indicate, for each rated current, the pre-arcing time vs. the RMS pre-arcing current.

Tolerance for the mean pre-arcing current  $\pm 10\%$

**Size 36x27  $I \leq 350$**

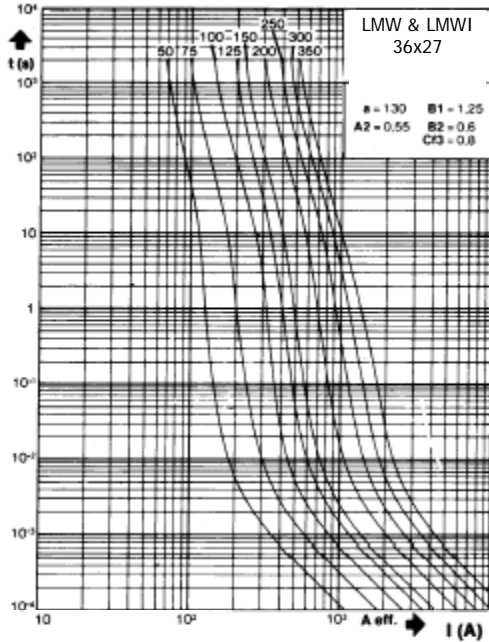

**Size 36x27  $I \geq 400$**

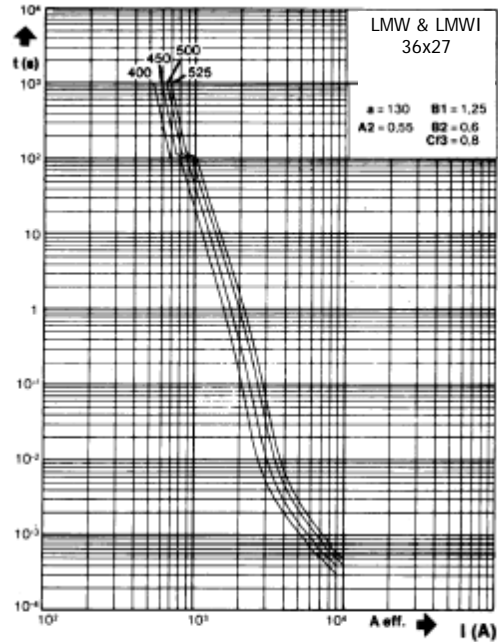

**Size 2x36x27  $I \leq 700$**

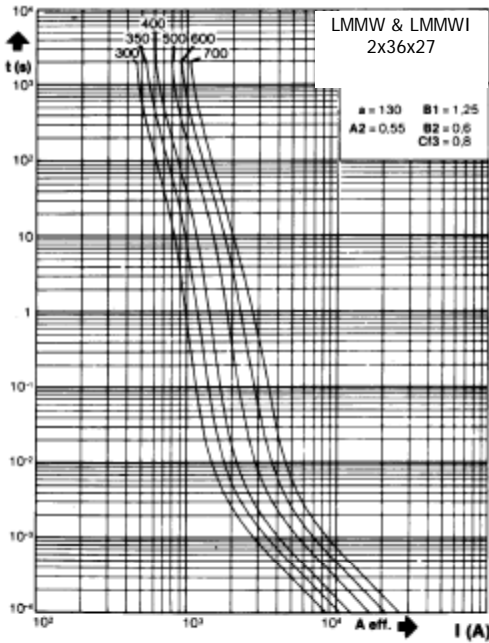

**Size 2x36x27  $I \geq 800$**

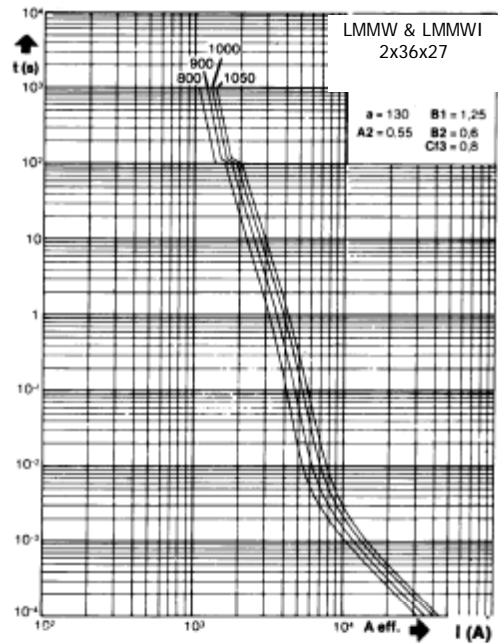

**Corrective Factor**

**Size 36x27 I ≤ 350 (LMW & LMWI)**

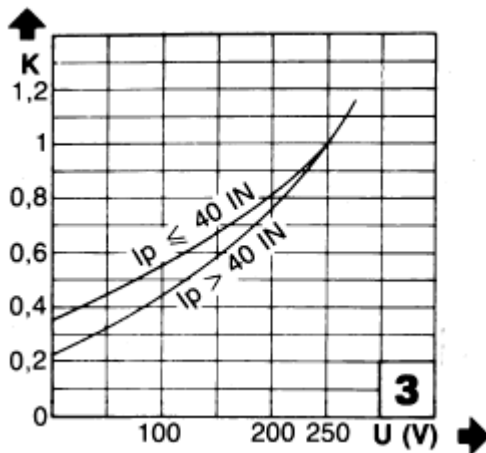

**Peak Arc Voltage**

**Size 36x27 I ≥ 400 (LMW & LMWI)**

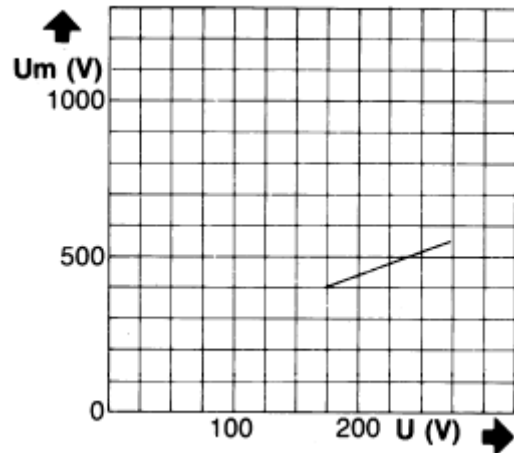

**Size 2x36x27 I ≤ 700 (LMMW & LMMWI)**

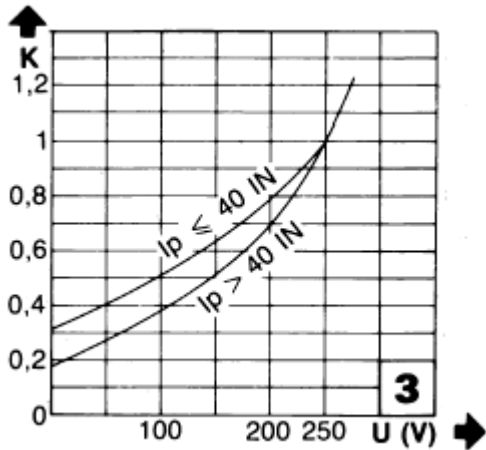

**Size 2x36x27 I ≥ 800 (LMMW & LMMWI)**

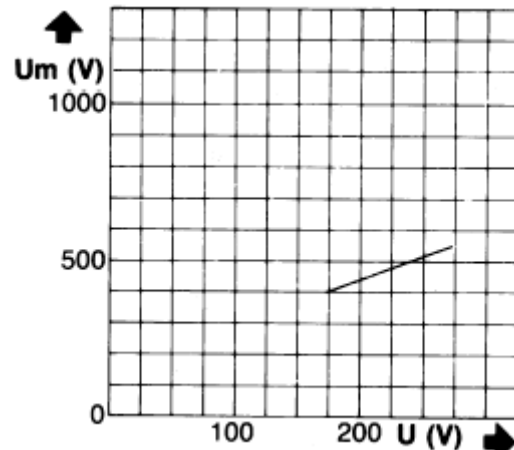

**Corrective factor:**

The mean curves show the variance of the total clearing time ( $I^2t$ ) and the total clearing duration  $t_t$  as a function of operating voltage  $U$ .

**Peak arc voltage :**

This curve shows the peak value  $U_m$  of the arc voltage which appears across the fuse link as a function of the operating voltage  $U @ \cos \varphi = 0.15$

**Outline Drawing & Ordering Information**

<p>LMW – 170gm</p>	<p>LMWI – 185g      BS88 Part 4</p>			
<p>LMMW – 290g</p>	<p>LMMWI – 900g      BS88 Part 4</p>			
<p><b>ORDERING INFORMATION</b> <span style="float: right;">(Please quote code as below)</span></p>				
<b>Voltage (V)</b>	<b>Size</b>	<b>Current Rating (A)</b>	<b>Ref.</b>	<b>Trip Indicator</b>
250	36x27 or 2x36x27	50 to 1050	LMW or LMMW	I
Order code: e.g. <b>50LMWI</b> = 250V 36x27, 50amp fuse with trip indicator switch				
<p><b>IXYS Semiconductor GmbH</b>                  Edisonstraße 15                  D-68623 Lampertheim                  Tel: +49 6206 503-0                  Fax: +49 6206 503-627                  E-mail: <a href="mailto:marcom@ixys.de">marcom@ixys.de</a></p>	<p>An IXYS Company</p> <p><a href="http://www.westcode.com">www.westcode.com</a></p> <p><a href="http://www.ixys.com">www.ixys.com</a></p>	<p><b>Westcode Semiconductors Ltd</b>                  Langley Park Way Langley Park                  Chippenham Wiltshire SN15 1GE                  Tel: +44 (0)1249 444524                  Fax: +44 (0)1249 659448                  E-mail: <a href="mailto:WSL.sales@westcode.com">WSL.sales@westcode.com</a></p> <p><b>Westcode Semiconductors Inc</b>                  3270 Cherry Avenue                  Long Beach CA 90807 USA                  Tel: +1 (562) 595 6971                  Fax: +1 (562) 595 8182                  E-mail: <a href="mailto:WSI.sales@westcode.com">WSI.sales@westcode.com</a></p>		
<p>The information contained herein is confidential and is protected by Copyright. The information may not be used or disclosed except with the written permission of and in the manner permitted by the proprietors Westcode Semiconductors Ltd. © Westcode Semiconductors Ltd.</p> <p>In the interest of product improvement, Westcode reserves the right to change specifications at any time without prior notice.</p>				

## Ultra Rapid Semiconductor Protection Fuse

### BS 88 Round Body Type Fuses – 690V

**British Standard  
Voltage Rating to 690V  
Current Ratings from 5A to 160A  
gR Characteristics  
Sizes 10x51, 17x49, 2x17x49**

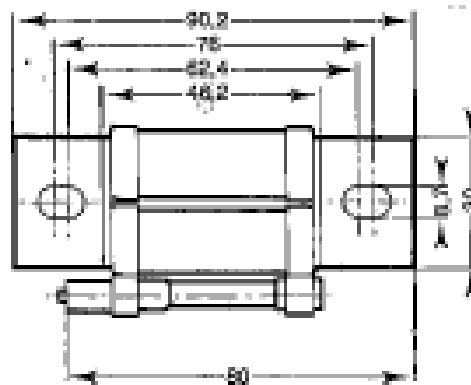

#### **Key Features:**

- ❖ Extremely high interrupting rating fuses for the protection of power semiconductors in accordance with IEC Standard 60269.1 and 4.
- ❖ 690V voltage rating complying with IEC 33
- ❖ Non Magnetic construction
- ❖ gR Characteristics (current ratings from 5 to 160A) according to VDE 636-23 and EC 60269.4
- ❖ Models are available with or without separate trip indicator
- ❖ Microswitch MC 6,3 GR 2-5N for fuses with separate trip indicator
- ❖ 17x49 gR fuses are UL recognised

**Main Characteristics:**

**CW : 10x51 Without trip indicator**

Size	Voltage U <sub>N</sub> (V)	Ref:	Micro Switch	Current rating I <sub>N</sub> (A)	Pre-arcing I <sup>2</sup> t @ 1 ms I <sup>2</sup> t <sub>p</sub> (A <sup>2</sup> s)	Total Clearing I <sup>2</sup> t @ U <sub>N</sub> (A <sup>2</sup> s)		Power Losses @		Tested Interrupting rating
						I <sub>p</sub> ≤ 50 In	I <sub>p</sub> > 50 In	0.8 In	In	
10x51	690	5CW	N	5	1.3	10	15	1.05	2	200kA @ 690V
		6CW	N	6	1.3	13.5	20.5	1.3	2.5	
		10CW	N	10	3.3	25	35	2.2	4.1	
		12CW	N	12	5.5	40	58	2.3	4.3	
		15CW	N	15	9.7	70	100	2.4	4.4	
		20CW	N	20	19.4	120	200	3.1	5.8	

**EEW : 2x17x49 Without trip indicator**

Size	Voltage U <sub>N</sub> (V)	Ref:	Micro Switch	Current rating I <sub>N</sub> (A)	Pre-arcing I <sup>2</sup> t @ 1 ms I <sup>2</sup> t <sub>p</sub> (A <sup>2</sup> s)	Total Clearing I <sup>2</sup> t @ U <sub>N</sub> (A <sup>2</sup> s)		Power Losses @		Tested Interrupting rating
						I <sub>p</sub> ≤ 50 In	I <sub>p</sub> > 50 In	0.8 In	In	
2x17x49	690	65EEW	N	65	210	1590	2270	9.5	17.4	200kA @ 690V
		75EEW	N	75	310	2300	3280	10.9	20	
		85EEW	N	85	430	3050	4350	11.9	21.9	
		90EEW	N	90	525	3600	5130	12.4	22.8	
		110EEW	N	110	850	5500	7840	13.8	26.5	
		140EEW	N	140	1730	11000	15700	15.5	28.5	
		150EEW	N	150	2090	13400	18500	15.6	28.7	
		160EEW	N	160	2500	15600	22800	16.9	31.5	

**EEWI : 2x17x49 With separated trip indicator**

Size	Voltage U <sub>N</sub> (V)	Ref:	Micro Switch	Current rating I <sub>N</sub> (A)	Pre-arcing I <sup>2</sup> t @ 1 ms I <sup>2</sup> t <sub>p</sub> (A <sup>2</sup> s)	Total Clearing I <sup>2</sup> t @ U <sub>N</sub> (A <sup>2</sup> s)		Power Losses @		Tested Interrupting rating
						I <sub>p</sub> ≤ 50 In	I <sub>p</sub> > 50 In	0.8 In	In	
2x17x49	690	65EEWI	Y	65	210	1590	2270	9.5	17.4	200kA @ 690V
		75EEWI	Y	75	310	2300	3280	10.9	20	
		85EEWI	Y	85	430	3050	4350	11.9	21.9	
		90EEWI	Y	90	525	3600	5130	12.4	22.8	
		110EEWI	Y	110	850	5500	7840	13.8	26.5	
		140EEWI	Y	140	1730	11000	15700	15.5	28.5	
		150EEWI	Y	150	2090	13400	18500	15.6	28.7	
		160EEWI	Y	160	2500	15600	22800	16.9	31.5	

Notes: Minimum operating voltage for integrated trip indicator = 20V.

Microswitch reference : MS 6.3 GR 2-5N



**Electrical Characteristics:**

**Times vs current characteristics**

These curves indicate, for each rated current, the pre-arcing time vs. the RMS pre-arcing current.

Tolerance for the mean pre-arcing current  $\pm 10\%$

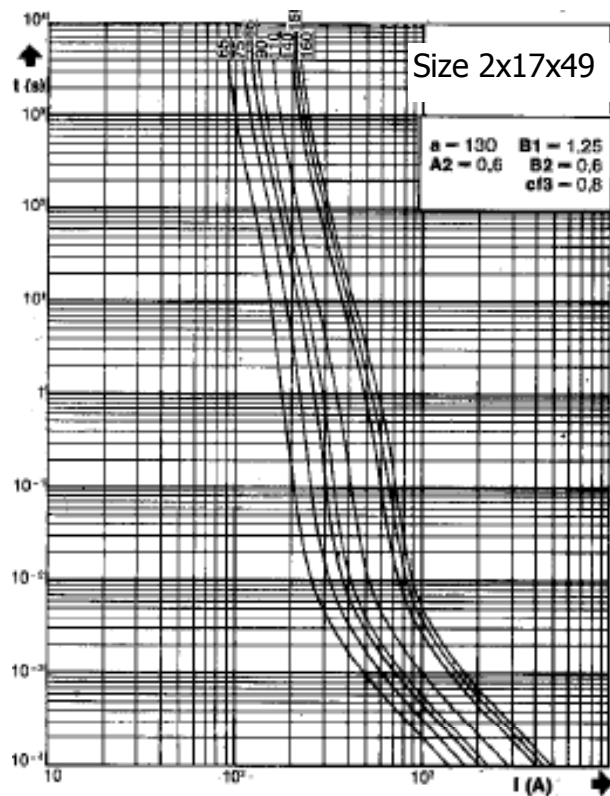
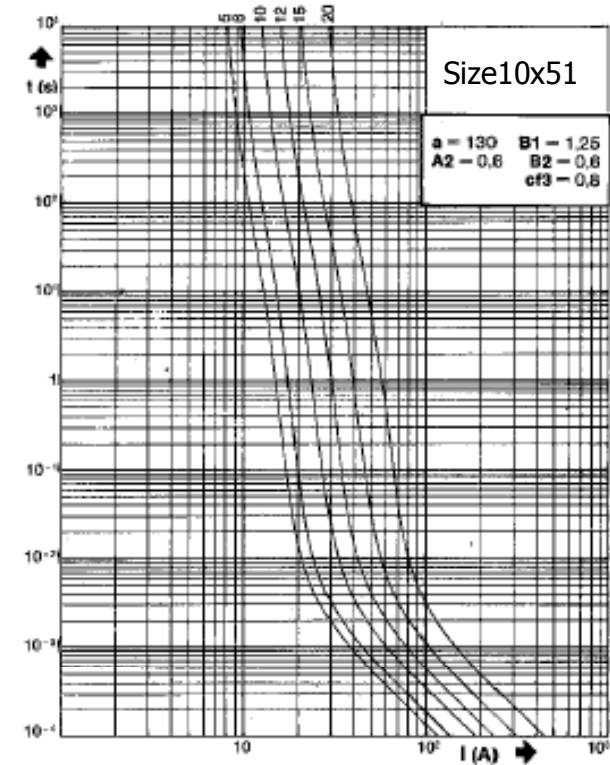

**Corrective Factor**

The mean curves show the variation of the total clearing time ( $I^2t_t$ ) and the total clearing duration  $t_t$  as a function of operating voltage U.

CW – Size 10x51

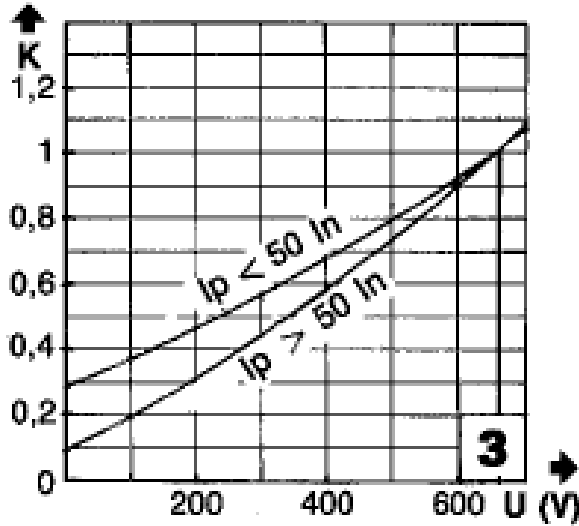

EEW & EEWI – Size 2x17x49

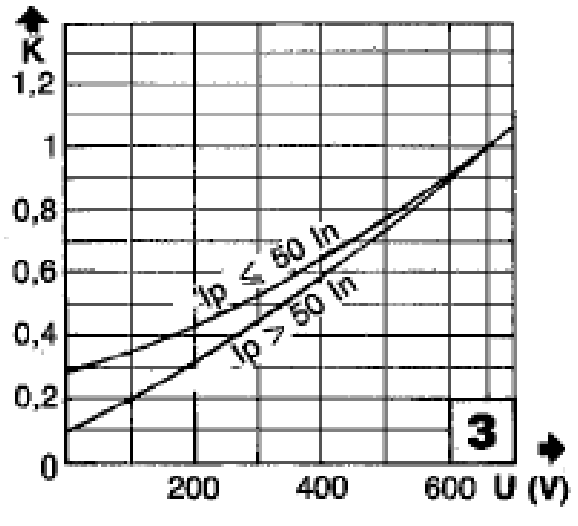

**Peak Arc Voltage**

This curve shows the peak value  $U_m$  of the arc voltage which appears across the fuse link as a function of the operating voltage U @  $\cos \varphi = 0.15$ .

CW – Size 10x51

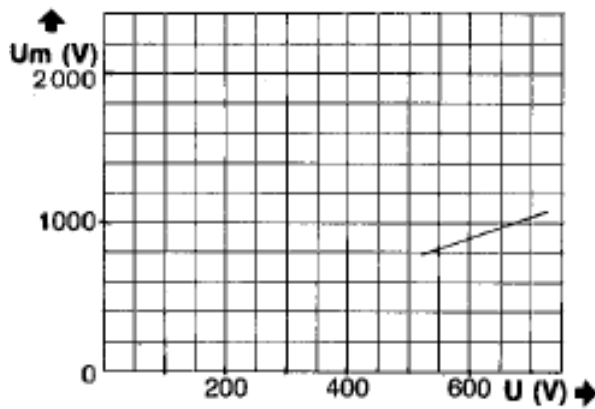

EEW & EEWI – Size 2x17x49

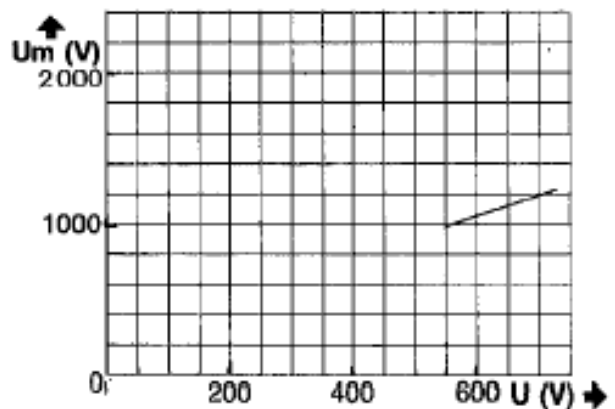

**Outline Drawing & Ordering Information**

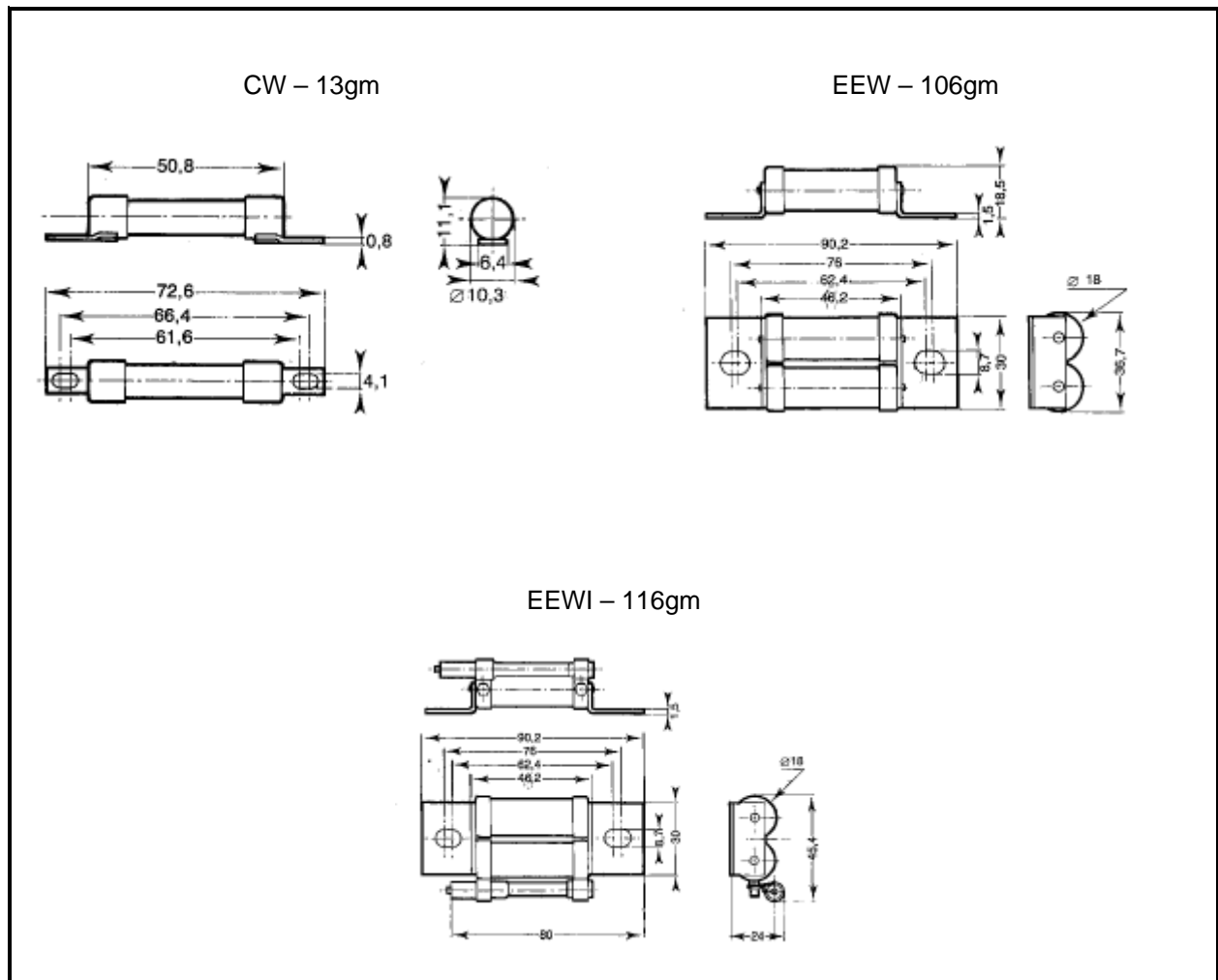

**ORDERING INFORMATION**

(Please quote code as below)

Style	Voltage	Current Rating (A)	Type	Trip Indicator
BS 88 Round Body	690V	5 to 160	CW or EEW	I

Order code: e.g. **65EEWI** = BS 88 Round Body – 65amp fuse with Trip indicator

**IXYS Semiconductor GmbH**  
 Edisonstraße 15  
 D-68623 Lampertheim  
 Tel: +49 6206 503-0  
 Fax: +49 6206 503-627  
 E-mail: [marcom@ixys.de](mailto:marcom@ixys.de)

**WESTCODE**  
 An IXYS Company

**Westcode Semiconductors Ltd**  
 Langley Park Way Langley Park  
 Chippenham Wiltshire SN15 1GE  
 Tel: +44 (0)1249 444524  
 Fax: +44 (0)1249 659448  
 E-mail: [WSL.sales@westcode.com](mailto:WSL.sales@westcode.com)

**IXYS Corporation**  
 3540 Bassett Street  
 Santa Clara CA 95054 USA  
 Tel: +1 (408) 982 0700  
 Fax: +1 (408) 496 0670  
 E-mail: [sales@ixys.com](mailto:sales@ixys.com)

[www.westcode.com](http://www.westcode.com)

[www.ixys.com](http://www.ixys.com)

**Westcode Semiconductors Inc**  
 3270 Cherry Avenue  
 Long Beach CA 90807 USA  
 Tel: +1 (562) 595 6971  
 Fax: +1 (562) 595 8182  
 E-mail: [WSI.sales@westcode.com](mailto:WSI.sales@westcode.com)

The information contained herein is confidential and is protected by Copyright. The information may not be used or disclosed except with the written permission of and in the manner permitted by the proprietors Westcode Semiconductors Ltd.

© Westcode Semiconductors Ltd.

In the interest of product improvement, Westcode reserves the right to change specifications at any time without prior notice.

## Ultra Rapid Semiconductor Protection Fuse

### BS 88 Round Body Type Fuses 690V

**British Standard BS88-4  
Voltage Rating - 690V  
gR and aR Characteristics  
Current Ratings from 12A to 100A  
Size 17x49**



#### **Key Features:**

- ❖ Extremely high interrupting rating fuses for the protection of power semiconductors as per IEC Standard 269.1 and 4.
- ❖ 690V voltage rating complying with IEC 33
- ❖ Non Magnetic construction
- ❖ gR Characteristics, current ratings from 12A to 90A in accordance with VDE 636-23 and EC 269.4
- ❖ aR Characteristics for current rating 100A in accordance with VDE 636-23 and IEC 60269.4
- ❖ Available with or without trip indicator switch
- ❖ Microswitch reference : MS 6.3 GR 2-5N for fuse with separate trip indicator
- ❖ These fuses are UL recognised

**Main Characteristics:**

**EW : 17x27 Without trip indicator**

Size	Voltage U <sub>N</sub> (V)	Ref:	Micro Switch	Current rating I <sub>N</sub> (A)	Pre-arcing I <sup>2</sup> t @ 1 ms I <sup>2</sup> t <sub>p</sub> (A <sup>2</sup> s)	Total Clearing I <sup>2</sup> t @ U <sub>N</sub> (A <sup>2</sup> s)	Power Losses @		Tested Interrupting rating
							0.8 In	In	
17x49	690	12EW	N	12	4.2	30	1.95	3.5	200kA @ 690V
		16EW	N	16	9.6	65	2.2	4	
		20EW	N	20	17.1	110	3	5.5	
		25EW	N	25	26.8	170	4.4	8	
		32EW	N	32	52.5	330	5	9	
		35EW	N	35	69	430	5.2	9.5	
		40EW	N	40	96	610	5.8	10.5	
		45EW	N	45	130	820	6.3	11.5	
		50EW	N	50	154	970	7.2	13	
		63EW	N	63	310	1950	8	14.5	
		75EW	N	75	520	3250	8.8	16	
		80EW	N	80	620	3900	9.4	17	
		90EW	N	90	840	5300	11	20	
100EW*	N	100	965	6150	13	23.5			

\* aR characteristics

**EWI : 17x27 With separate trip indicator**

Size	Voltage U <sub>N</sub> (V)	Ref:	Micro Switch	Current rating I <sub>N</sub> (A)	Pre-arcing I <sup>2</sup> t @ 1 ms I <sup>2</sup> t <sub>p</sub> (A <sup>2</sup> s)	Total Clearing I <sup>2</sup> t @ U <sub>N</sub> (A <sup>2</sup> s)	Power Losses @		Tested Interrupting rating
							0.8 In	In	
17x49	690	12EWI	Y	12	4.2	30	1.95	3.5	200kA @ 690V
		16EWI	Y	16	9.6	65	2.2	4	
		20EWI	Y	20	17.1	110	3	5.5	
		25EWI	Y	25	26.8	170	4.4	8	
		32EWI	Y	32	52.5	330	5	9	
		35EWI	Y	35	69	430	5.2	9.5	
		40EWI	Y	40	96	610	5.8	10.5	
		45EWI	Y	45	130	820	6.3	11.5	
		50EWI	Y	50	154	970	7.2	13	
		63EWI	Y	63	310	1950	8	14.5	
		75EWI	Y	75	520	3250	8.8	16	
		80EWI	Y	80	620	3900	9.4	17	
		90EWI	Y	90	840	5300	11	20	
100EWI*	Y	100	965	6150	13	23.5			

\* aR characteristics

Notes: Minimum operating voltage for integrated trip indicator = 20V

Microswitch reference : MS 6.3 GR 2-5N

**Electrical Characteristics:**

**Times vs current characteristics**

These curves indicate, for each rated current, the pre-arcing time vs. the RMS pre-arcing current. Tolerance for the mean pre-arcing current  $\pm 9\%$

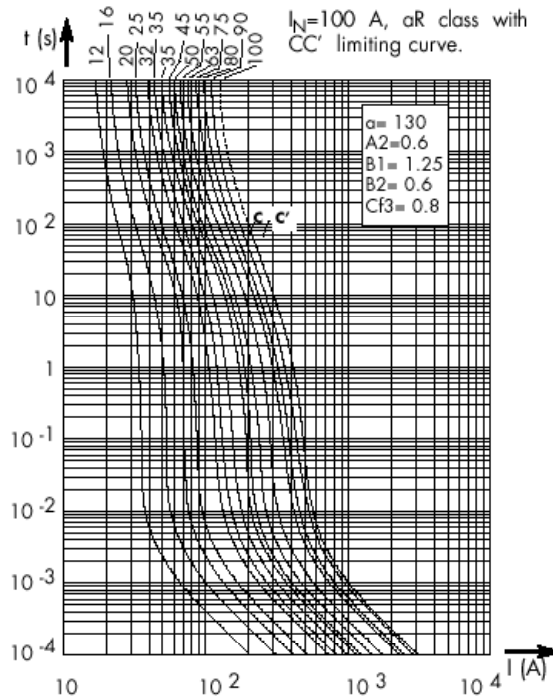

**Total clearing I<sup>2</sup>T:**

The horizontal curves show for each rated current maximum values of total clearing  $I^2t$  ( $I^2t_t$ ) as a function of prospective current  $I_p$  @ 690V.  $\cos\phi = 0.15$ . Oblique lines indicate total clearing duration  $T_t$  and associated pre-arcing duration in brackets.

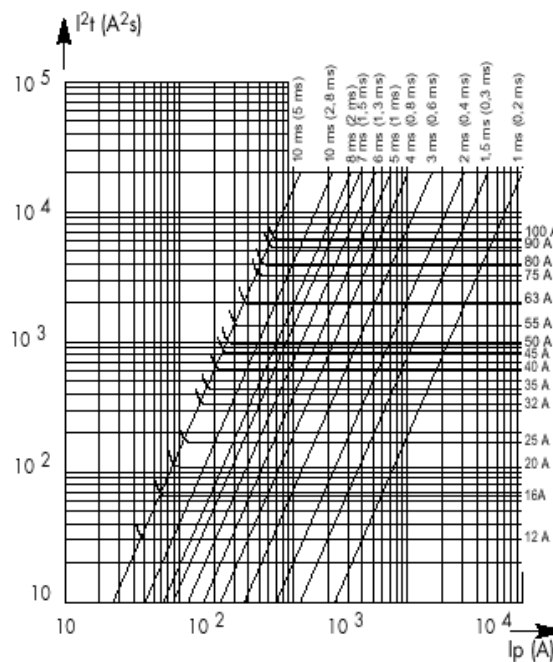

**Cut off Characteristics:**

Curves show, for each rating, value of peak let-through current  $I_C$  as a function of available fault current  $I_p$ .

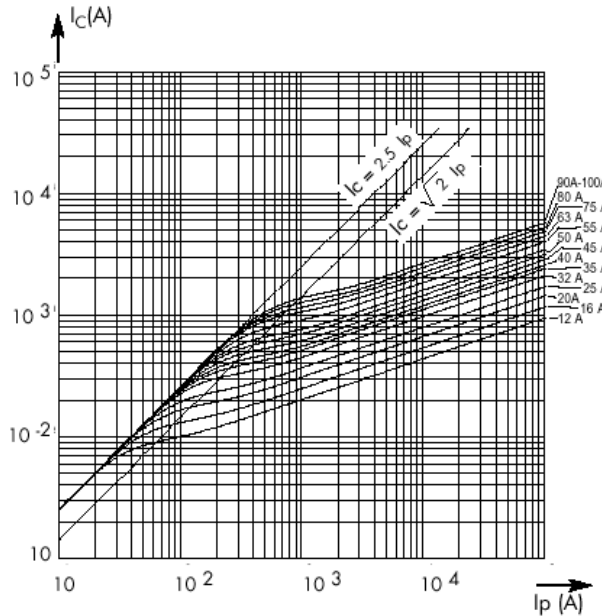

**Corrective Factor**

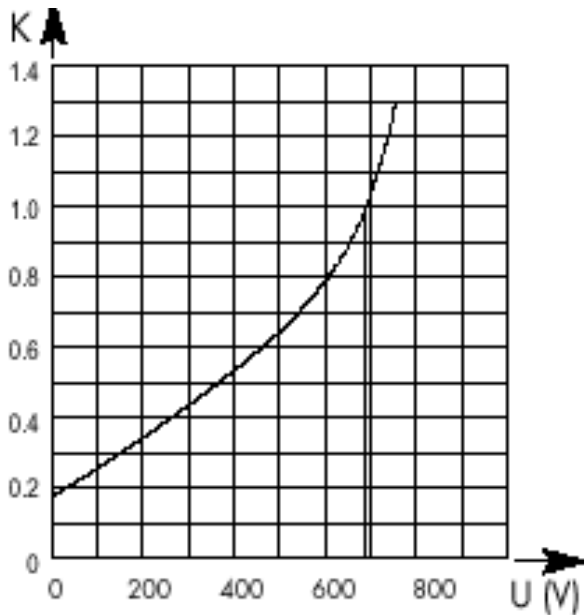

The mean curves show the variation of the total clearing time ( $I^2 t_t$ ) and the total clearing duration  $t_t$  as a function of operating voltage  $U$ .

**Peak Arc Voltage**

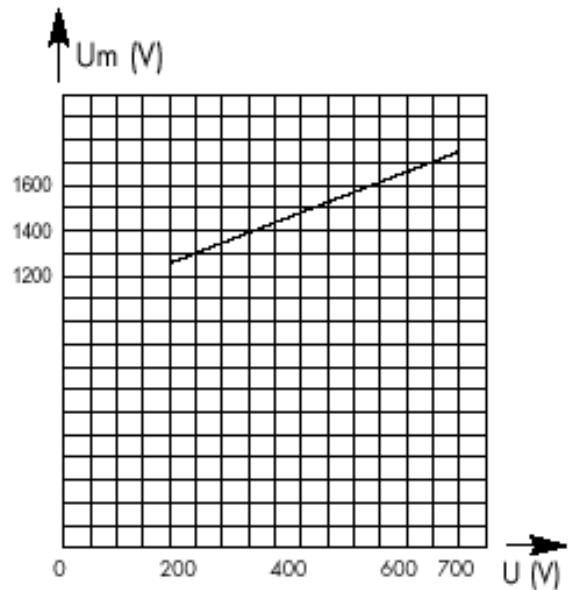

This curve shows the peak value  $U_m$  of the arc voltage which appears across the fuse link as a function of the operating voltage  $U$  @  $\cos \varphi = 0.15$ .

**Outline Drawing & Ordering Information**

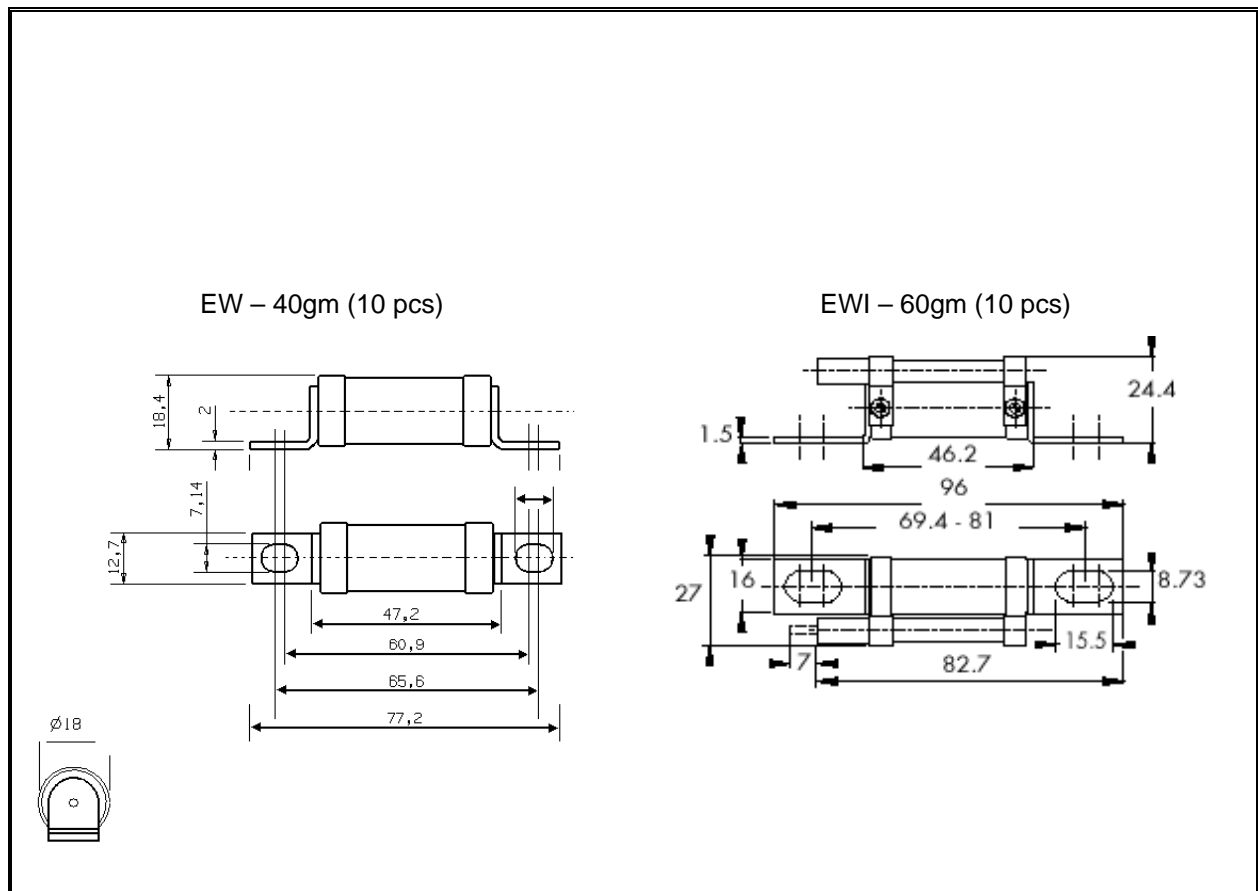

ORDERING INFORMATION		(Please quote code as below)		
Style	Voltage	Current Rating (A)	Type	Trip Indicator
BS 88 Round Body	690V	12 - 100	EW	I

Order code: e.g. **45EW** = BS 88 Round Body 45 amp fuse without trip indicator.

**IXYS Semiconductor GmbH**  
 Edisonstraße 15  
 D-68623 Lampertheim  
 Tel: +49 6206 503-0  
 Fax: +49 6206 503-627  
 E-mail: [marcom@ixys.de](mailto:marcom@ixys.de)

**WESTCODE**  
 An IXYS Company  
[www.westcode.com](http://www.westcode.com)  
[www.ixys.com](http://www.ixys.com)

**Westcode Semiconductors Ltd**  
 Langley Park Way Langley Park  
 Chippenham Wiltshire SN15 1GE  
 Tel: +44 (0)1249 444524  
 Fax: +44 (0)1249 659448  
 E-mail: [WSL.sales@westcode.com](mailto:WSL.sales@westcode.com)

**IXYS Corporation**  
 3540 Bassett Street  
 Santa Clara CA 95054 USA  
 Tel: +1 (408) 982 0700  
 Fax: +1 (408) 496 0670  
 E-mail: [sales@ixys.com](mailto:sales@ixys.com)

**Westcode Semiconductors Inc**  
 3270 Cherry Avenue  
 Long Beach CA 90807 USA  
 Tel: +1 (562) 595 6971  
 Fax: +1 (562) 595 8182  
 E-mail: [WSI.sales@westcode.com](mailto:WSI.sales@westcode.com)

The information contained herein is confidential and is protected by Copyright. The information may not be used or disclosed except with the written permission of and in the manner permitted by the proprietors Westcode Semiconductors Ltd.

© Westcode Semiconductors Ltd.

In the interest of product improvement, Westcode reserves the right to change specifications at any time without prior notice.



## Ultra Rapid Semiconductor Protection Fuse

### BS 88 Square Body Fuses - 690V

**British Standard  
Voltage Rating upto 690V  
Current Ratings from 75A to 400A  
aR Characteristics  
Size 000**

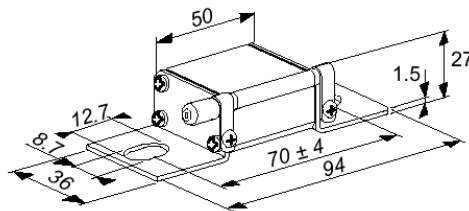













#### **Key Features:**













- ❖ Extremely high interrupting rating fuses for the protection of power semiconductors as per IEC Standard 60269.1 and 4, also EN 60269-1 and 4.
- ❖ 500v to 690V voltage rating complying with IEC 33
- ❖ Non Magnetic construction
- ❖ aR Characteristics with current rating from 75A to 400A in accordance with VDE 636-23 and EC 269.4
- ❖ Available with or without blown fuse trip indicator
- ❖ Microswitch : MS 6.3 GR 2-5N for separate trip indicator models

**Main Characteristics:**

**070BQCLAxxxxN – without trip indicator**

Size	Voltage U <sub>N</sub> (V)	Ref:		Micro Switch	Current rating I <sub>N</sub> (A)	Pre-arcing I <sup>2</sup> t @ 1 ms I <sup>2</sup> t <sub>p</sub> (A <sup>2</sup> s)	Total Clearing I <sup>2</sup> t @ U <sub>N</sub> (A <sup>2</sup> s)	Power Losses @		Tested Interrupting rating
								0.8 I <sub>n</sub>	I <sub>n</sub>	
000	660	070BQCL0075N		N	75	350	2250	11.2	20.5	200kA @ 660V
		070BQCL0080N		N	80	390	2500	11.6	21	
		070BQCL0100N		N	100	690	4200	12.7	23	
		070BQCL0110N		N	110	950	6800	13.5	24.5	
		070BQCL0125N		N	125	1300	8900	14.3	26	
		070BQCL0160N		N	160	2700	16000	17	31	
		070BQCL0200N		N	200	5250	31500	19.8	36	
		070BQCL0250N		N	250	9900	52000	24.8	45	
	690 +6%	070BQCL0315N		N	315	15500	82000	31.9	58	
	500	500	050BQCL0350N		N	350	22400	110000	31.9	58
050BQCL0400N				N	400	33200	160000	36.3	66	

**070BQCLAxxxxN – with separate trip indicator**

Size	Voltage U <sub>N</sub> (V)	Ref:		Micro Switch	Current rating I <sub>N</sub> (A)	Pre-arcing I <sup>2</sup> t @ 1 ms I <sup>2</sup> t <sub>p</sub> (A <sup>2</sup> s)	Total Clearing I <sup>2</sup> t @ U <sub>N</sub> (A <sup>2</sup> s)	Power Losses @		Tested Interrupting rating
								0.8 I <sub>n</sub>	I <sub>n</sub>	
000	660V	070BQCL0075I		Y	75	350	2250	11.2	20.5	200kA @ 660V
		070BQCL0080I		Y	80	390	2500	11.6	21	
		070BQCL0100I		Y	100	690	4200	12.7	23	
		070BQCL0110I		Y	110	950	6800	13.5	24.5	
		070BQCL0125I		Y	125	1300	8900	14.3	26	
		070BQCL0160I		Y	160	2700	16000	17	31	
		070BQCL0200I		Y	200	5250	31500	19.8	36	
		070BQCL0250I		Y	250	9900	52000	24.8	45	
	690V +6%	070BQCL0315I		Y	315	15500	82000	31.9	58	
	500V	500V	050BQCL0350I		Y	350	22400	110000	31.9	58
050BQCL0400I				Y	400	33200	160000	36.3	66	

Notes: Minimum operating voltage for integrated trip indicator = 20V  
 Microswitch reference : MS 6.3 GR 2-5N

**Electrical Characteristics:**

**Times vs Current Characteristics:**

These curves indicate, for each rated current, the pre-arcing time vs. the RMS pre-arcing current. Tolerance for the mean pre-arcing current  $\pm 8\%$

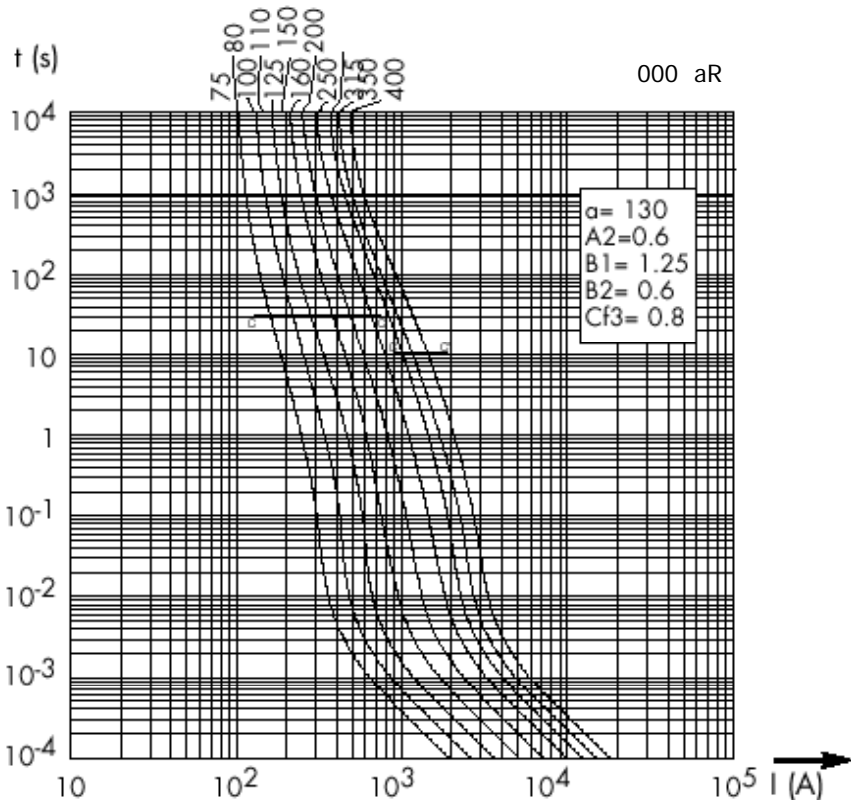

**Total clearing I<sup>2</sup>t:**

Horizontal curves show, for each rated current, values of total clearing  $I^2t (I^2t_c)$  as a function of prospective current  $I_p @ U_N$  with  $\cos\phi = 0.15$ . Oblique lines indicate total clearing duration  $T_t$ , with associated pre-arcing duration in brackets.

**I  $\leq$  315A**

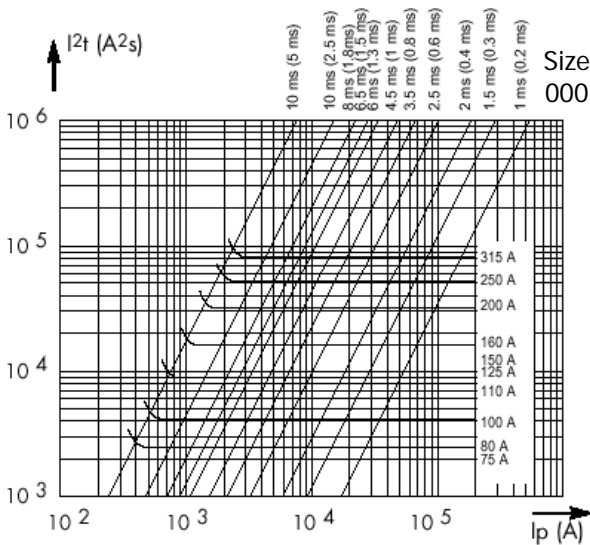

**I  $\geq$  400A**

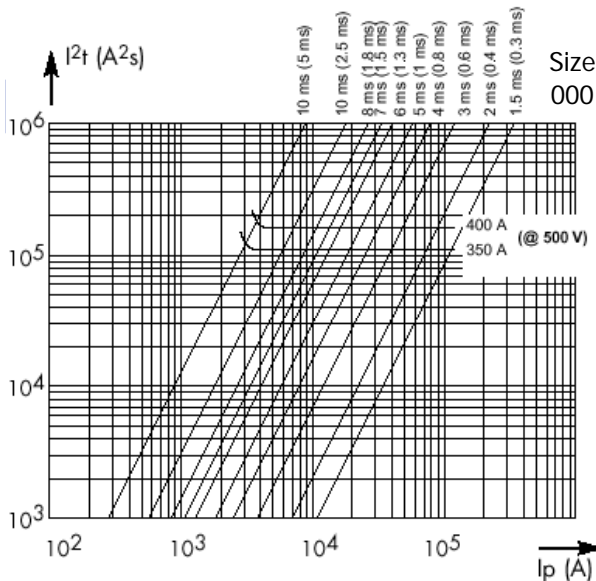

**Corrective Factor:**

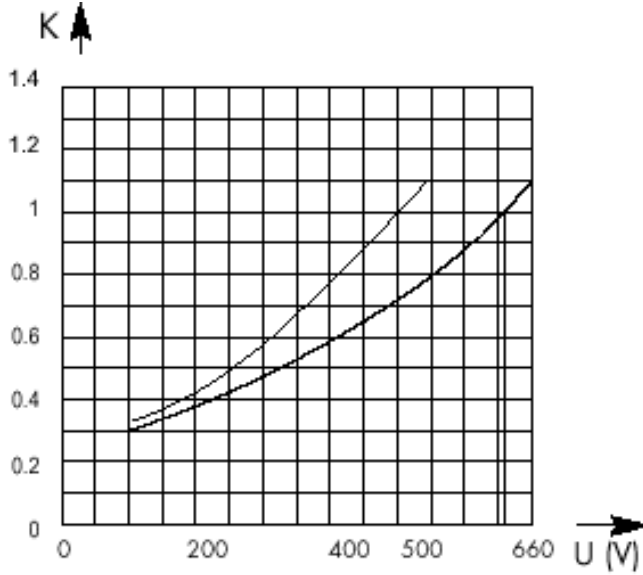

The mean curves show the variation of the total clearing time ( $I^2t_t$ ) and the total clearing duration  $t_t$  as a function of operating voltage U.

**Peak Arc Voltage:**

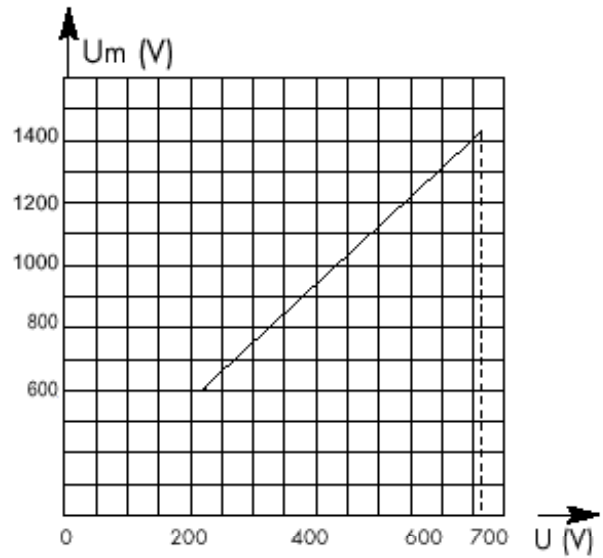

Curve shows peak value  $U_m$  of arc voltage which appears across fuse link as a function of the operating voltage U @  $\cos \varphi = 0.15$

**Dissipated Power Corrective Factor:**

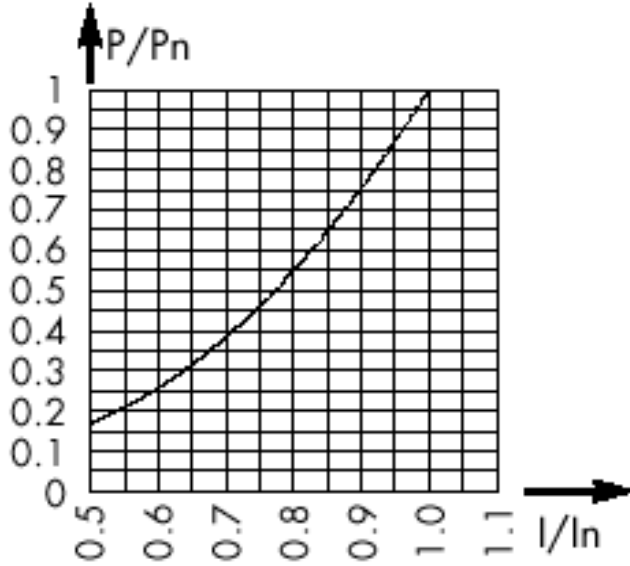

Curve enables computation of power losses P for a  $I_N$ -rated fuse as a function of RMS current I (as a multiple of  $I_N$  for steady state operation).

**Outline Drawing & Ordering Information:**

070BQCLAxN – 125g

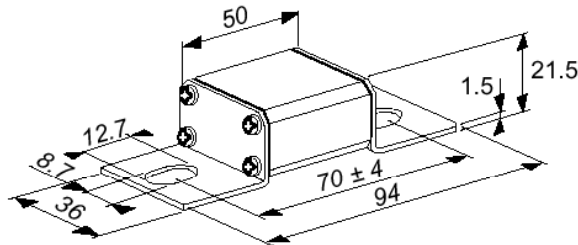

With Trip Indicator Switch (070BQCLAxI) – 135g

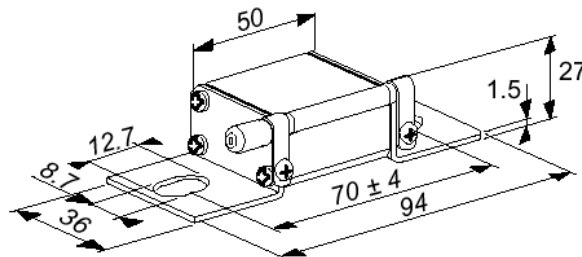

**ORDERING INFORMATION**

(Please quote code as below)

Voltage Rating (V)	Type	Current Rating (A)	With / without Trip Indicator
690 + 6%	BQCL	75 - 400	I or N

Order code: e.g. **070BQCL0125N** = 700V British Standard Square Body 125amp fuse without trip indicator switch

**IXYS Semiconductor GmbH**  
 Edisonstraße 15  
 D-68623 Lampertheim  
 Tel: +49 6206 503-0  
 Fax: +49 6206 503-627  
 E-mail: [marcom@ixys.de](mailto:marcom@ixys.de)

**WESTCODE**  
 An IXYS Company

**Westcode Semiconductors Ltd**  
 Langley Park Way Langley Park  
 Chippenham Wiltshire SN15 1GE  
 Tel: +44 (0)1249 444524  
 Fax: +44 (0)1249 659448  
 E-mail: [WSL.sales@westcode.com](mailto:WSL.sales@westcode.com)

**IXYS Corporation**  
 3540 Bassett Street  
 Santa Clara CA 95054 USA  
 Tel: +1 (408) 982 0700  
 Fax: +1 (408) 496 0670  
 E-mail: [sales@ixys.com](mailto:sales@ixys.com)

[www.westcode.com](http://www.westcode.com)

[www.ixys.com](http://www.ixys.com)

**Westcode Semiconductors Inc**  
 3270 Cherry Avenue  
 Long Beach CA 90807 USA  
 Tel: +1 (562) 595 6971  
 Fax: +1 (562) 595 8182  
 E-mail: [WSI.sales@westcode.com](mailto:WSI.sales@westcode.com)

The information contained herein is confidential and is protected by Copyright. The information may not be used or disclosed except with the written permission of and in the manner permitted by the proprietors Westcode Semiconductors Ltd.

© Westcode Semiconductors Ltd.

In the interest of product improvement, Westcode reserves the right to change specifications at any time without prior notice.

## Ultra Rapid Semiconductor Protection Fuse European Square Body Type Fuses













French Standard End Contacts  
Voltage Ratings 450V - 690V  
Current Ratings 40A – 2500A  
aR Characteristics  
Sizes 0, 1, 2, 3















### Key Features:

- ❖ Extremely high interrupting rating fuses for the protection of power semiconductors in accordance with IEC Standard 60269.1 and 4.
- ❖ Exceptionally low  $I^2t$ , power losses
- ❖ Highly reliable low voltage trip indicator system
- ❖ Non Magnetic construction
- ❖ Conform to UL, IEC, DIN and VDE standards
- ❖ Increased technical performance gives higher ratings and reduction in volume and weight
- ❖ All models available with integrated trip-indicator
- ❖ Microswitch system reference MS 3V 1-5















**Main Characteristics:**

Size	Voltage Rating $U_N$ (V)	Ref:		Current rating $I_N$ (A)	Pre-arcing $I^2t @ 1 \text{ ms}$ $I^2t_p (10^3 \text{ kA}^2\text{s})$	Total Clearing $I^2t @ U_N$ $(10^3 \text{ kA}^2\text{s})$	Watt Losses		Tested Interrupting rating
							$0.8I_N$	$I_N$	
0	690V	069UR0S0040B		40	0.11	0.68	3	5.5	200kA @690V
		069UR0S0050B		50	0.12	0.68	4.5	9	
		069UR0S0063B		63	0.20	1.1	7.5	14	
		069UR0S0080B		80	0.33	1.75	9.5	19	
		069UR0S0100B		100	0.47	2.5	13	26	
		069UR0S0125B		125	0.85	4.5	15	30	
		069UR0S0160B		160	1.6	8.5	18.5	37	
		069UR0S0200B		200	3	15.5	21.5	43	
		069UR0S0250B		250	5.8	30	25	50	
		069UR0S0315B		315	12	62	22.5	55	
		069UR0S0350B		350	15.5	80	30	60	
		069UR0S0400B		400	23	120	32.5	65	
		069UR0S0450B		450	26	150	44	88	
		069UR0S0500B		500	41	240	44	88	
		069UR0S0550B		550	52	300	45	90	

















Notes: Minimum operating voltage for integrated trip indicator = 20V  
Microswitch Reference : MS 3V 1-5

Size	Voltage Rating $U_N$ (V)	Ref:		Current rating $I_N$ (A)	Pre-arcing $I^2t @ 1 \text{ ms}$ $I^2t_p (10^3 \text{ kA}^2\text{s})$	Total Clearing $I^2t @ U_N$ $(10^3 \text{ kA}^2\text{s})$	Watt Losses		Tested Interrupting rating
							$0.8I_N$	$I_N$	
1	690V	069UR1S0160B		160	1.3	7.7	27.5	35	200kA @690V
		069UR1S0200B		200	2.6	13.5	22.5	45	
		069UR1S0250B		250	4.7	25	25.5	52	
		069UR1S0315B		315	7.5	40	32.5	65	
		069UR1S0350B		350	10.5	55	33.5	67	
		069UR1S0400B		400	19	100	34	68	
		069UR1S0450B		450	26.5	140	35	70	
		069UR1S0500B		500	37	195	36	72	
		069UR1S0550B		550	52	280	37.5	75	
		069UR1S0630B		630	75	390	42.5	85	
		069UR1S0700B		700	95	490	85	95	
		069UR1S0800B		800	140	800	52.5	105	

Notes: Minimum operating voltage for integrated trip indicator = 20V  
Microswitch Reference : MS 3V 1-5

Size	Voltage Rating $U_N$ (V)	Ref:		Current rating $I_N$ (A)	Pre-arcing $I^2t @ 1 \text{ ms}$ $I^2t_p(10^3 \text{ kA}^2\text{s})$	Total Clearing $I^2t @ U_N$ $(10^3 \text{ kA}^2\text{s})$	Watt Losses		Tested Interrupting rating
							$0.8I_N$	$I_N$	
2	690V	069UR2S0400B		400	15	80	32.5	75	200kA @ 690V
		069UR2S0450B		450	20	115	40	80	
		069UR2S0500B		500	28	145	45	90	
		069UR2S0550B		550	37	195	47.5	95	
		069UR2S0630B		630	54	280	52.5	105	
		069UR2S0700B		700	76	400	-	110	
		069UR2S0800B		800	115	600	60	120	
	690V +6%	069UR2S0900B		900	170	900	62.5	125	200kA @ 690V
		069UR2S1000B		1000	240	1250	77.5	135	
	600V	060UR2S1100B		1100	270	1670	82.5	165	160kA @ 600V
	550V	055UR2S1250B		1250	410	2400	90	180	150kA @ 550V
	500V	050UR2S1400B		1400	555	3400	95	190	130kA @ 500V
		050UR2S1600B		1600	870	5300	97.5	195	
450V	045UR2S1800B		1800	1050	3700	115	230	110kA @ 450V	

Notes: Minimum operating voltage for integrated trip indicator = 20V Microswitch Reference : MS 3V 1-5

Size	Voltage Rating $U_N$ (V)	Ref:		Current rating $I_N$ (A)	Pre-arcing $I^2t @ 1 \text{ ms}$ $I^2t_p(10^3 \text{ kA}^2\text{s})$	Total Clearing $I^2t @ U_N$ $(10^3 \text{ kA}^2\text{s})$	Watt Losses		Tested Interrupting rating
							$0.8I_N$	$I_N$	
3	690V	069UR3S0500B		500	19	100	52.5	105	200kA @ 690V
		069UR3S0550B		550	27	140	55	110	
		069UR3S0630B		630	40	210	60	120	
		069UR3S0700B		700	55	300	-	125	
		069UR3S0800B		800	95	490	65	130	
		069UR3S0900B		900	135	700	67.5	135	
		069UR3S1000B		1000	170	900	77.5	155	
		069UR3S1100B		1100	240	1260	80	160	
	690V +6%	069UR3S1250B		1250	350	1850	90	180	200kA @ 690V
		069UR3S1400B		1400	480	2500	100	200	
	660V	069UR3S1500B		1500	500	3000	115	230	260kA @ 600V
		069UR3S1600B		1600	555	3300	120	240	
		069UR3S1800B		1800	720	4450	130	260	
	550V	055UR3S2000B		2000	950	5600	145	290	150kA @ 550V
	500V	050UR3S2250B		2250	1250	7600	165	330	130kA @ 500V
	450V	045UR3S2500B		2500	1870	6540	165	330	110kA @ 450V

Notes: Minimum operating voltage for integrated trip indicator = 20V Microswitch Reference : MS 3V 1-5

**Electrical Characteristics:**

**Times vs current characteristics**

The following curves indicate the pre-arcing time for each rated current as a function of RMS value of pre-arcing current I:

- Tolerances on this current  $\pm 8\%$
- Beyond 30 sec or 10 sec, small overloads must be eliminated by another device.



Curve CC' represents the maximum times taken by the associated device to clear small overloads; only its horizontal line is represented.

Its oblique line must be plotted according to sketch in top right corner:

- The intersection of the fuse and CC' curves indicates the minimum breaking current  $I_{pm}$  of the fuse.

**Size 0**

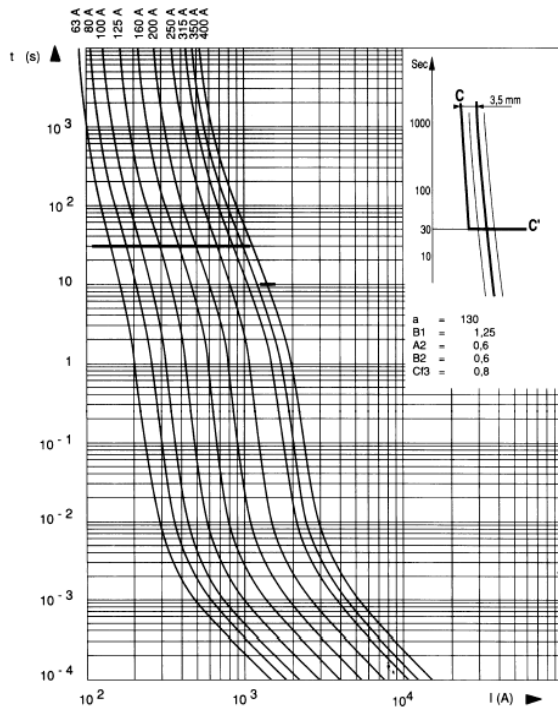

**Size 1**

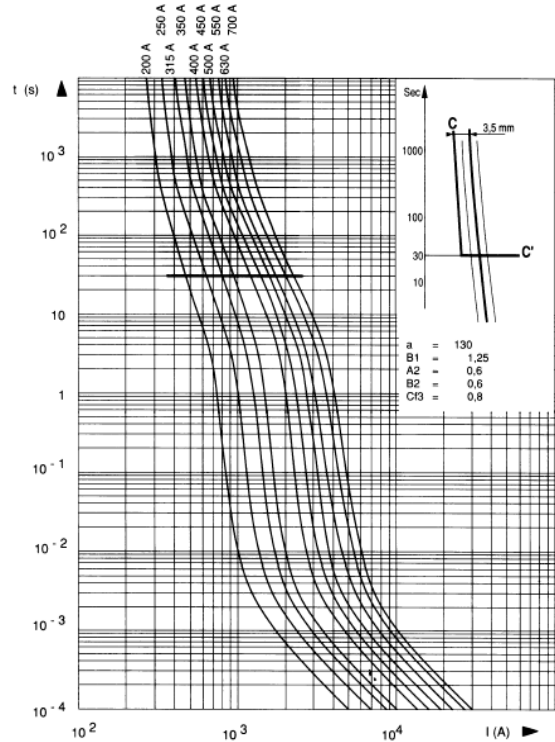

**Size 2**

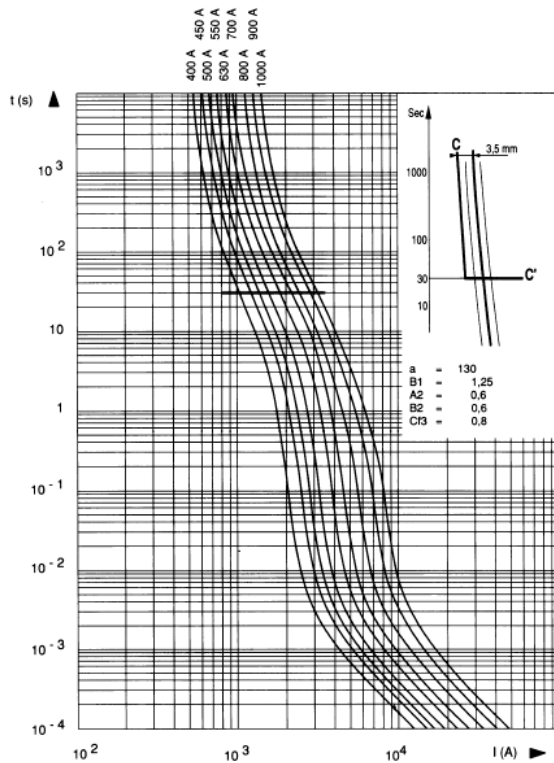

**Size 3**

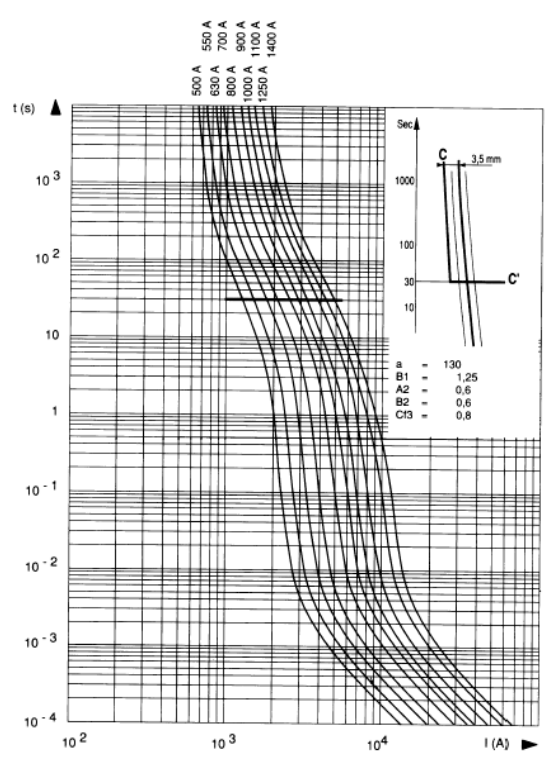

**Total clearing I<sup>2</sup>T:**

The horizontal curves given below indicated the maximum values of total operating I<sup>2</sup>t (I<sup>2</sup>t<sub>t</sub>) as a function of prospective current I<sub>p</sub> @ 660V, cosφ = 0.15. Oblique lines indicate the corresponding total operating time T<sub>t</sub>, with pre-arcing time in brackets.

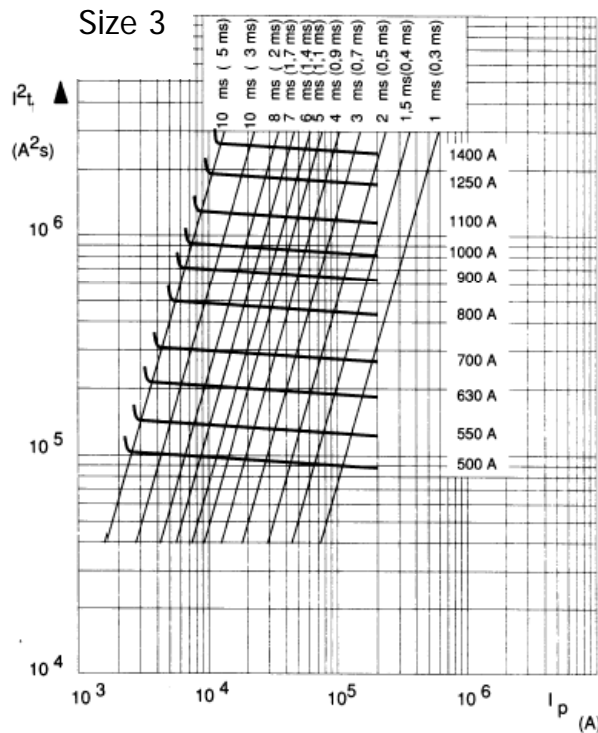
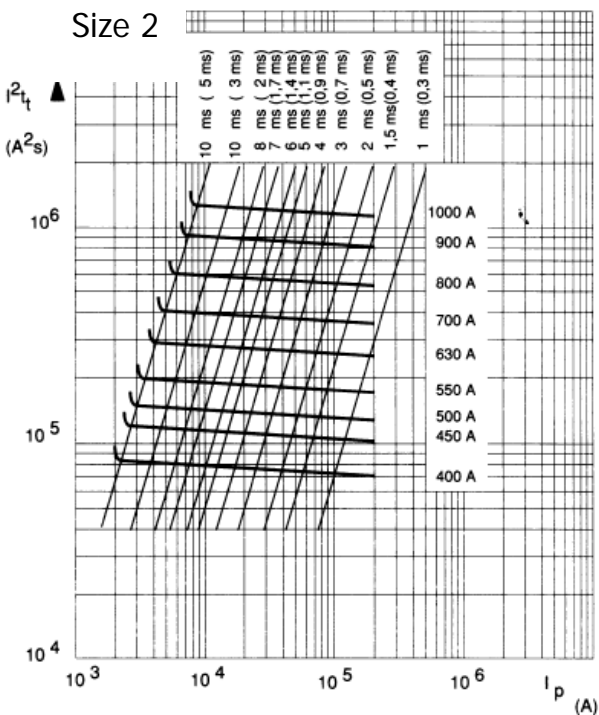
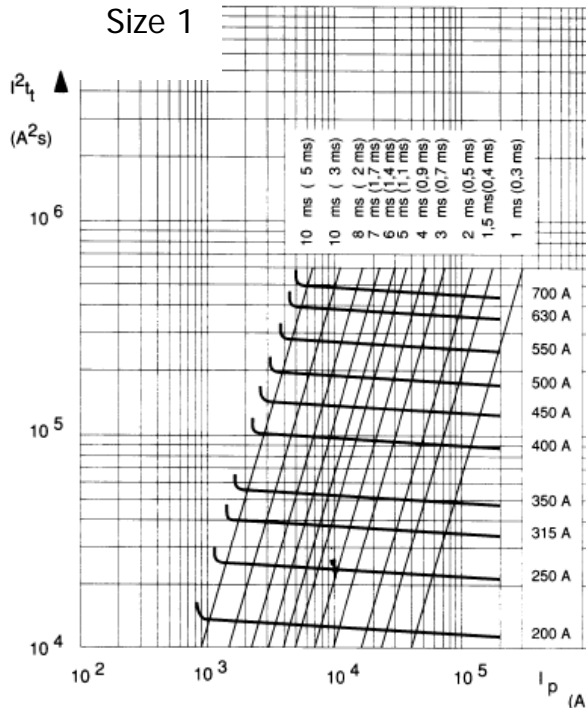
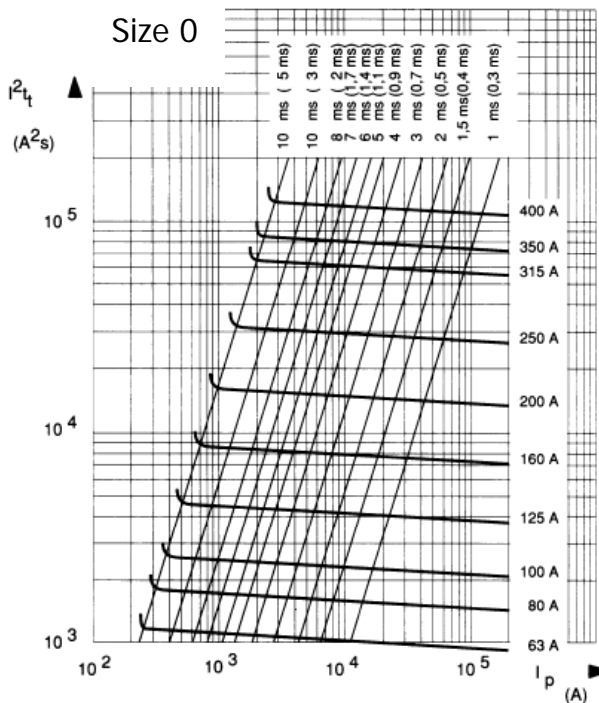

**Cut off Characteristics:**

The curves below indicate, for each rated current, the peak value  $I_c$  that the current may reach as a function of the prospective fault current  $I_p$ .

**Size 0**

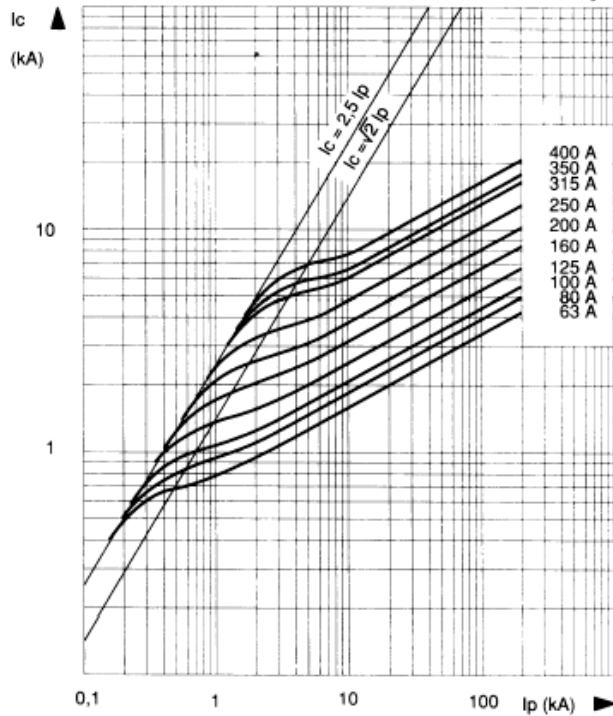

**Size 1**

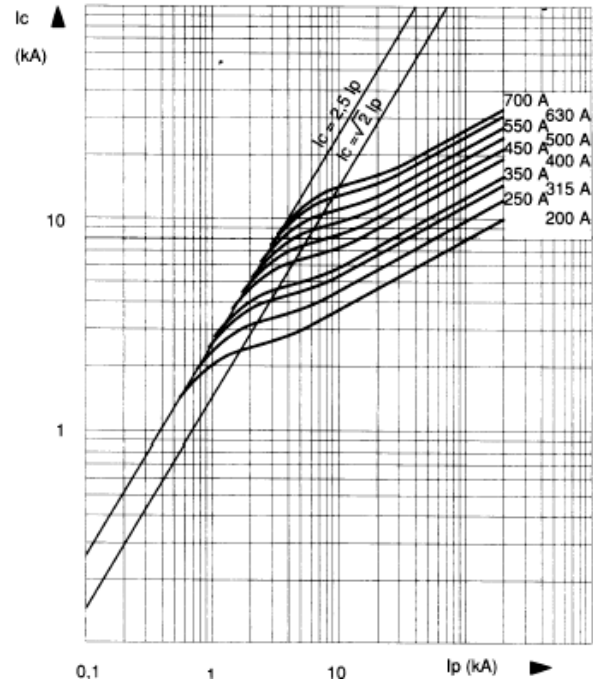

**Size 2**

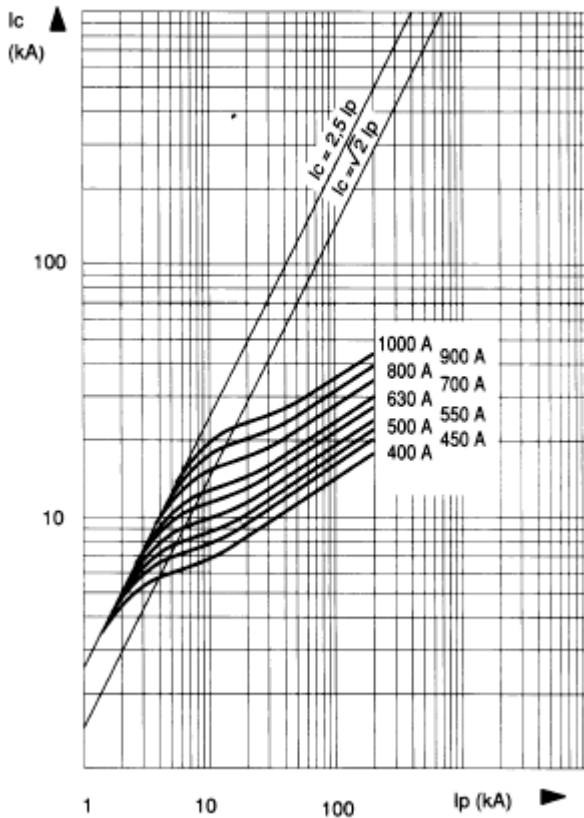

**Size 3**

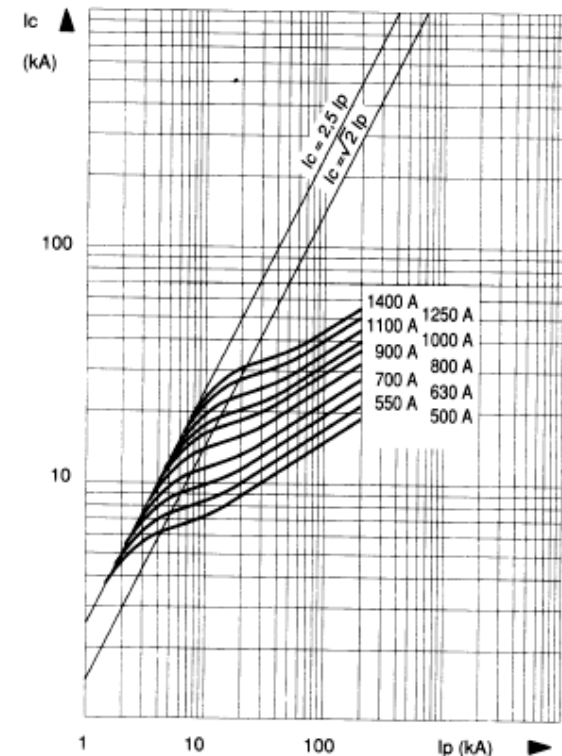

**Correction Factor, Peak Arc Voltage and**

**I<sup>2</sup>t Multiplier Coefficient**

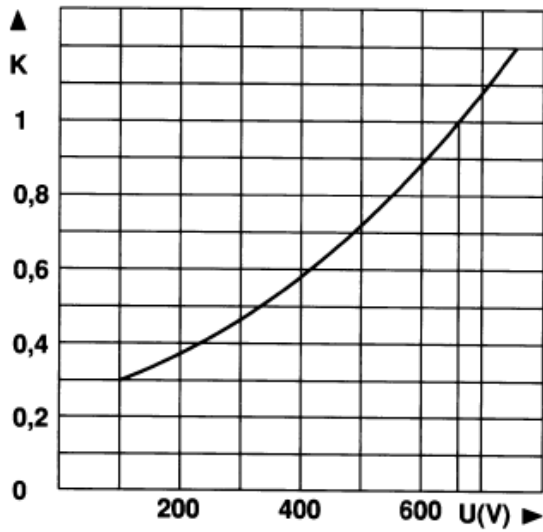

The above Mean curve shows variation of total clearing time (I<sup>2</sup>t<sub>i</sub>) and total operating time T<sub>i</sub> in accordance with working voltage U.

**Peak Arc Voltage**

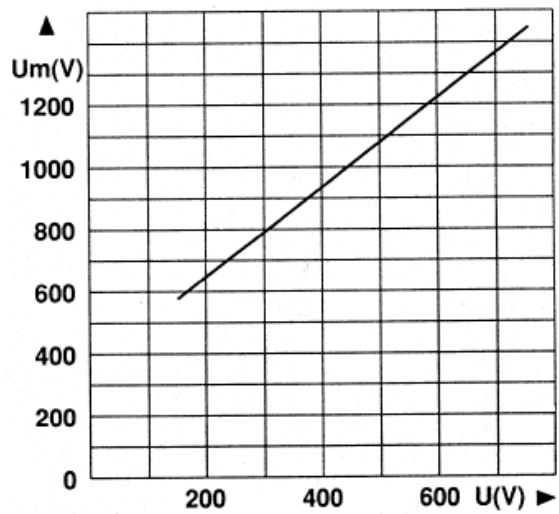

Curve indicating peak arc voltage Um which may appear across fuse terminals as a function of working voltage U @ cos φ = 0.15.

**Dissipated Power**

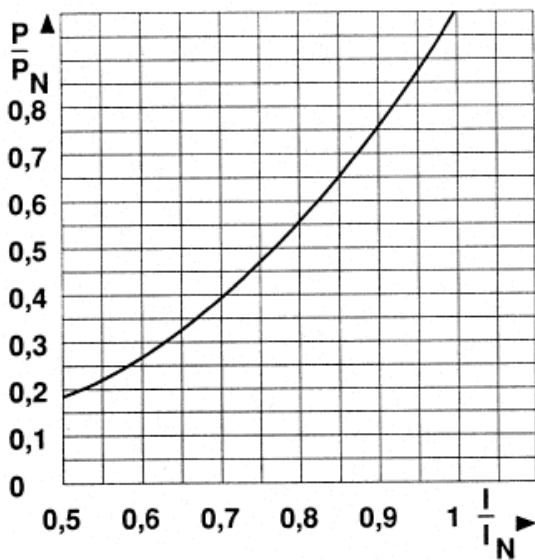

Curve enabling calculation of dissipated power P by a fuse rated I<sub>N</sub>, as a function of the RMS current I, in multiples of I<sub>N</sub> in a steady state.

**Outline Drawing & Ordering Information:**

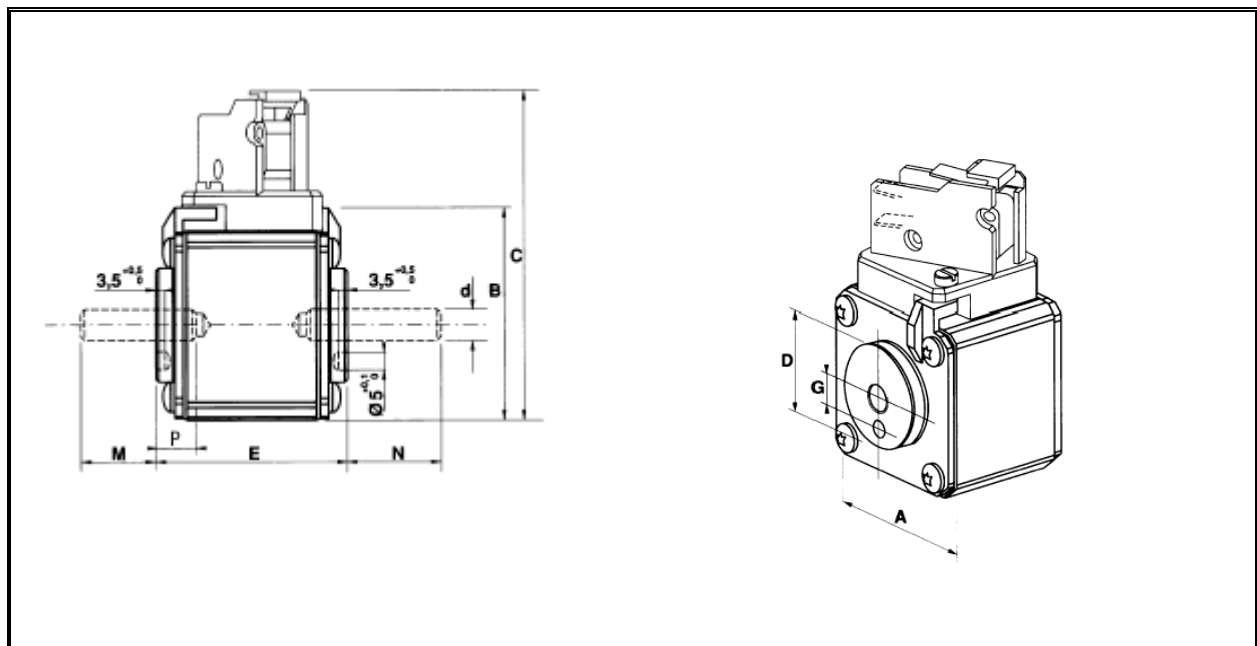

**Dimensions (mm)**

Size	A	B	C	D	M	N	E	d	G	P	Weight
0	40	46.5	82	26	22	27	50.6	M8	9	6	245g
1	51	56.5	91	30	19	24	50.6	M8	9	9	370g
2	60	65.5	100	38 (* 42)	19	39	50.6	M10	15	9	510g(600g)
3	74.5	79.5	114	46 (* 52)	24	39	50.6	M12	15	9	790g(910g)

**ORDERING INFORMATION**

(Please quote code as below)

Voltage Rating (V)	Type	Size	Fixing	Current Rating (A)	Indicator
450 – 690	UR	0, 1, 2, 3	S	0040 – 2500	B

Order code: e.g. **069UR2S0630B** = 690V, French End Contact, Size 2, DIN110, 630A, with button indicator

**IXYS Semiconductor GmbH**  
 Edisonstraße 15  
 D-68623 Lampertheim  
 Tel: +49 6206 503-0  
 Fax: +49 6206 503-627  
 E-mail: [marcom@ixys.de](mailto:marcom@ixys.de)

**WESTCODE**  
 An IXYS Company

**Westcode Semiconductors Ltd**  
 Langley Park Way Langley Park  
 Chippenham Wiltshire SN15 1GE  
 Tel: +44 (0)1249 444524  
 Fax: +44 (0)1249 659448  
 E-mail: [WSL.sales@westcode.com](mailto:WSL.sales@westcode.com)

**IXYS Corporation**  
 3540 Bassett Street  
 Santa Clara CA 95054 USA  
 Tel: +1 (408) 982 0700  
 Fax: +1 (408) 496 0670  
 E-mail: [sales@ixys.net](mailto:sales@ixys.net)

[www.westcode.com](http://www.westcode.com)

[www.ixys.net](http://www.ixys.net)

**Westcode Semiconductors Inc**  
 3270 Cherry Avenue  
 Long Beach CA 90807 USA  
 Tel: +1 (562) 595 6971  
 Fax: +1 (562) 595 8182  
 E-mail: [WSI.sales@westcode.com](mailto:WSI.sales@westcode.com)

The information contained herein is confidential and is protected by Copyright. The information may not be used or disclosed except with the written permission of and in the manner permitted by the proprietors Westcode Semiconductors Ltd.

© Westcode Semiconductors Ltd.

In the interest of product improvement, Westcode reserves the right to change specifications at any time without prior notice.

## Ultra Rapid Semiconductor Protection Fuse European Square Body Type











French Standard End Contact  
Voltage Rating 650V to 1250V  
Current Rating 63A to 1800A  
aR Characteristics  
Sizes 0, 1, 2, 3













### Key Features:

- ❖ Extremely high interrupting rating fuses for the protection of power semiconductors in accordance with IEC standard 60269.1 and 4.
- ❖ Exceptionally low  $I^2t$  watt losses
- ❖ Conform to UL Recognition for many devices, CSA investigated, IEC, DIN and VDE standards
- ❖ Increased technical performance giving higher ratings and reduction in volume and weight
- ❖ Non Magnetic construction
- ❖ Highly reliable low voltage , integrated trip indicator system
- ❖ Microswitch reference MS 7V 1-5











**Main Characteristics:**

Size	Voltage U <sub>N</sub> (V)	Ref:		Current rating I <sub>N</sub> (A)	Pre-arcing I <sup>2</sup> t @ 1 ms I <sup>2</sup> t <sub>p</sub> (kA <sup>2</sup> s)	Total Clearing I <sup>2</sup> t @ U <sub>N</sub> (kA <sup>2</sup> s)	Watt Losses 0.8I <sub>N</sub> I <sub>N</sub>		Tested Interrupting rating
0	1250V	125UR0S0063B		63	0.21	1.2	13	26	100kA @ 1250V
		125UR0S0080B		80	0.47	2.7	13.5	27	
		125UR0S0100B		100	0.83	4.8	15	30	
		125UR0S0125B		125	1.3	7.5	19	38	
		125UR0S0160B		160	2.5	15	22.5	45	
		125UR0S0200B		200	4.7	27	27	54	
		125UR0S0250B		250	9.6	55	29	58	
	1200V	120UR0S0280B		280	14.0	82	30.5	61	100kA @ 1200V
		120UR0S0315B		315	20.0	115	33	66	
	1100V	110UR0S0350B		350	28	158	34	68	150kA @ 1100V

Notes: Minimum operating voltage for integrated trip indicator = 20V  
 Microswitch reference : MS 7V 1-5















Size	Voltage U <sub>N</sub> (V)	Ref:		Current rating I <sub>N</sub> (A)	Pre-arcing I <sup>2</sup> t @ 1 ms I <sup>2</sup> t <sub>p</sub> (kA <sup>2</sup> s)	Total Clearing I <sup>2</sup> t @ U <sub>N</sub> (kA <sup>2</sup> s)	Watt Losses 0.8I <sub>N</sub> I <sub>N</sub>		Tested Interrupting rating
1	1250V	125UR1S0160B		160	2.6	15	23	46	100kA @ 1250V
		125UR1S0200B		200	4.7	27	27	54	
		125UR1S0250B		250	8.9	51	30.5	61	
		125UR1S0280B		280	12	68	34	68	
		125UR1S0315B		315	16	92	36.5	73	
		125UR1S0350B		350	22	127	38	76	
		125UR1S0400B		400	38	220	38	76	
		125UR1S0450B		450	47	270	43.5	87	
	1100V	110UR1S0500B		500	68	390	45	90	150kA @ 1100V
		110UR1S0550B		550	84	485	49	98	
110UR1S0630B			630	125	725	52.5	105		

Notes: Minimum operating voltage for integrated trip indicator = 20V  
 Microswitch reference : MS 7V 1-5

Size	Voltage U <sub>N</sub> (V)	Ref:		Current rating I <sub>N</sub> (A)	Pre-arcing I <sup>2</sup> t @ 1 ms I <sup>2</sup> t <sub>p</sub> (kA <sup>2</sup> s)	Total Clearing I <sup>2</sup> t @ U <sub>N</sub> (kA <sup>2</sup> s)	Watt Losses		Tested Interrupting rating
							0.8I <sub>N</sub>	I <sub>N</sub>	
2	1250V	125UR2S0280B		280	10	60	36	72	100kA @ 1250V
		125UR2S0315B		315	15	87	38	76	
		125UR2S0350B		350	21	120	38.5	77	
		125UR2S0400B		400	32	190	40	80	
		125UR2S0450B		450	44	255	46.5	87	
		125UR2S0500B		500	57	330	47	94	
		125UR2S0550B		550	68	390	55	110	
		125UR2S0630B		630	105	610	56.5	113	
	1100V	110UR2S0700B		700	145	815	61	122	150kA @ 1100V
		110UR2S0800B		800	215	1240	62.5	125	

Notes: Minimum operating voltage for integrated trip indicator = 20V

Microswitch reference : MS 7V 1-5

Size	Voltage U <sub>N</sub> (V)	Ref:		Current rating I <sub>N</sub> (A)	Pre-arcing I <sup>2</sup> t @ 1 ms I <sup>2</sup> t <sub>p</sub> (kA <sup>2</sup> s)	Total Clearing I <sup>2</sup> t @ U <sub>N</sub> (kA <sup>2</sup> s)	Watt Losses		Tested Interrupting rating
							0.8I <sub>N</sub>	I <sub>N</sub>	
3	1250V	125UR3S0315B		315	12	68	42,0	84	100kA @1250V
		125UR3S0350B		350	17	100	43,0	86	
		125UR3S0400B		400	25	145	46,5	93	
		125UR3S0450B		450	35	205	49,5	99	
		125UR3S0500B		500	44	255	55,0	110	
		125UR3S0550B		550	57	330	58,8	116	
		125UR3S0630B		630	84	485	62,5	125	
		125UR3S0700B		700	110	640	67,5	135	
		125UR3S0800B		800	190	640	68,0	136	
	1200V	120UR3S0900B		900	250	1090	75,0	150	100kA @1200V
	1000V	100UR3S1000B		1000	370	2130	76,0	152	150kA @1000V
	950V	095UR3S1100B		1100	445	2430	84,0	168	150kA @950V
	900V*	090UR3S1250B		1250	585	3080	93,0	186	150kA @900V
	850V	085UR3S1400B	-	1400	755	3700	105,0	210	150kA @850V
	690V	069UR3S1600B	-	1600	1430	5740	-	203	180kA @690V
	600V	060UR3S1800B	-	1800	2040	7150	-	206	120kA @600V

\* Not available with Blades

Notes: Minimum operating voltage for integrated trip indicator = 20V

Micro switch reference : MS 7V 1-5



**Electrical Characteristics:**

**Times vs current characteristics**

The following curves indicate the pre-arcing time for each rated current as a function of RMS value of pre-arcing current I:

- Tolerances on this current  $\pm 8\%$
- Beyond 30 sec, small overloads must be eliminated by another device.

Curve CC' represents the maximum times taken by the associated device to clear small overloads; only its horizontal line is represented. Its oblique line must be plotted according to sketch in top right corner:

- The intersection of the fuse and CC' curves indicates the minimum breaking current  $I_{pm}$  of the fuse.

**Size 0**

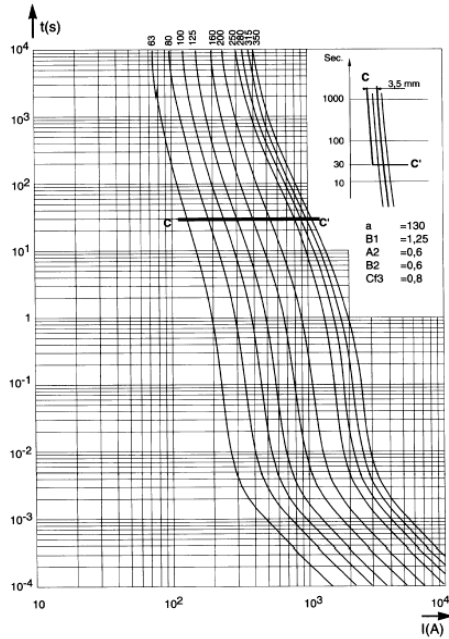

**Size 1**

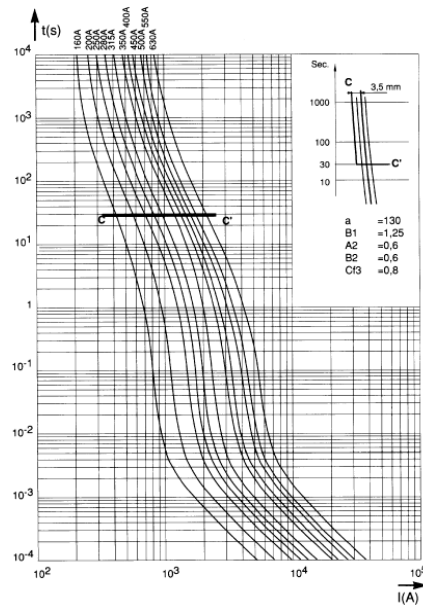

**Size 2**

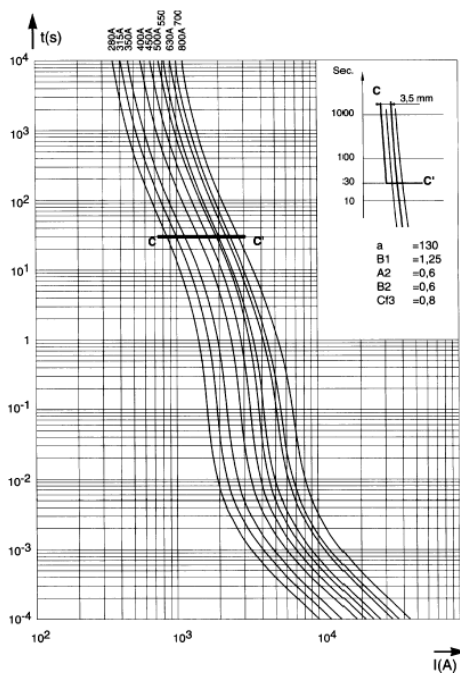

**Size 3**

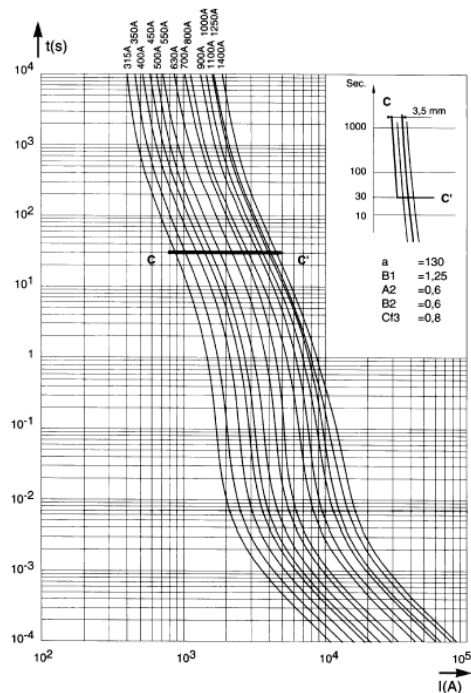

**Total clearing  $I^2T$ :**

The horizontal curves given below indicate the maximum values of total operating  $I^2t$  ( $I^2t_t$ ) as a function of prospective current  $I_p$  @ 1000V or 850V,  $\cos\phi = 0.15$ .

Oblique lines indicate the corresponding total operating time  $T_t$ , with pre-arcing time in brackets.

**Size 0**

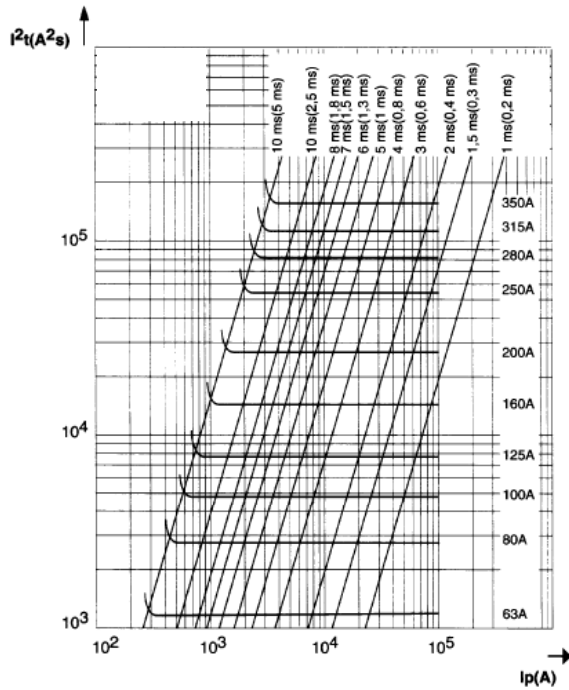

**Size 1**

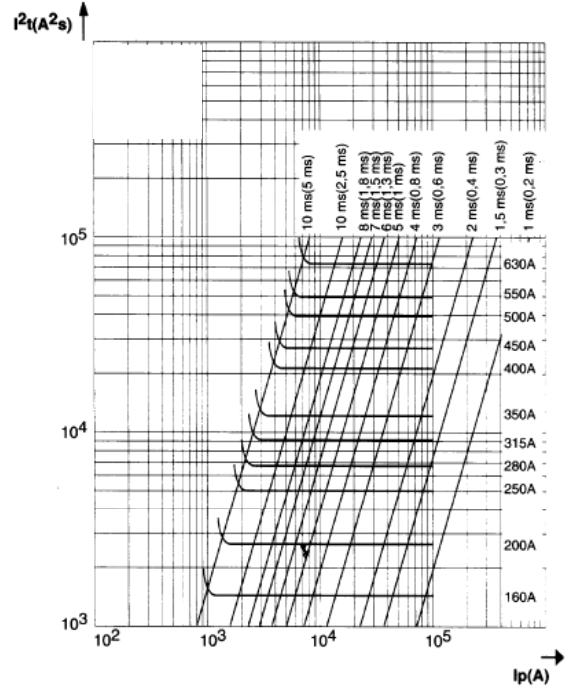

**Size 2**

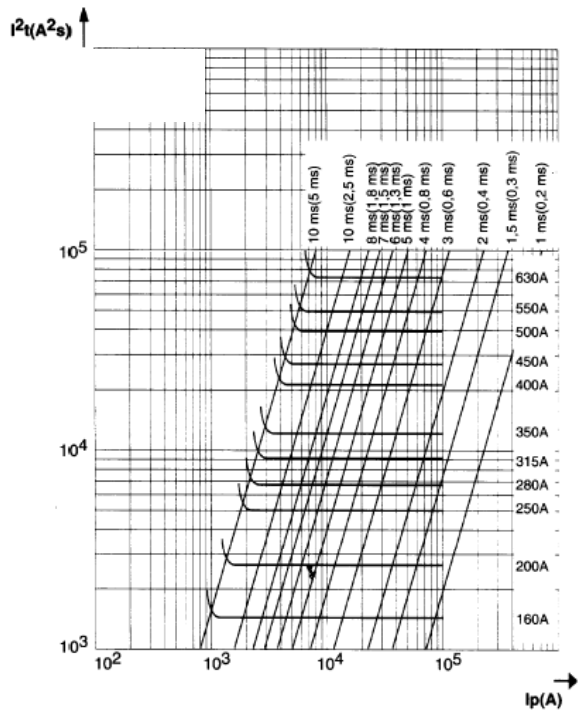

**Size 3**

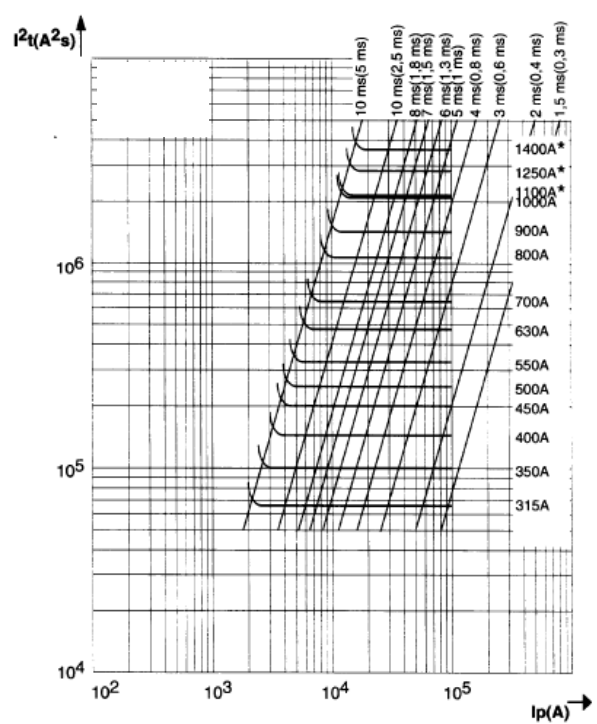

**Cut off Characteristics:**

The curves below indicate, for each rated current, the peak value  $I_c$  that the current may reach as a function of the prospective fault current  $I_p$ .

**Size 0**

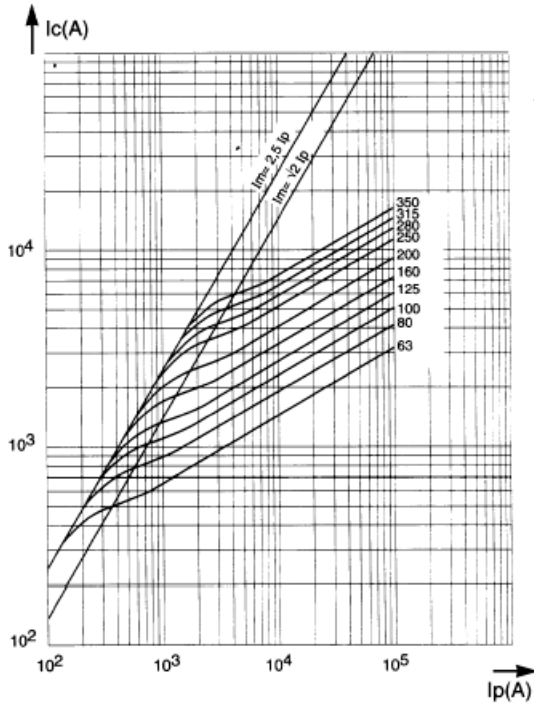

**Size 1**

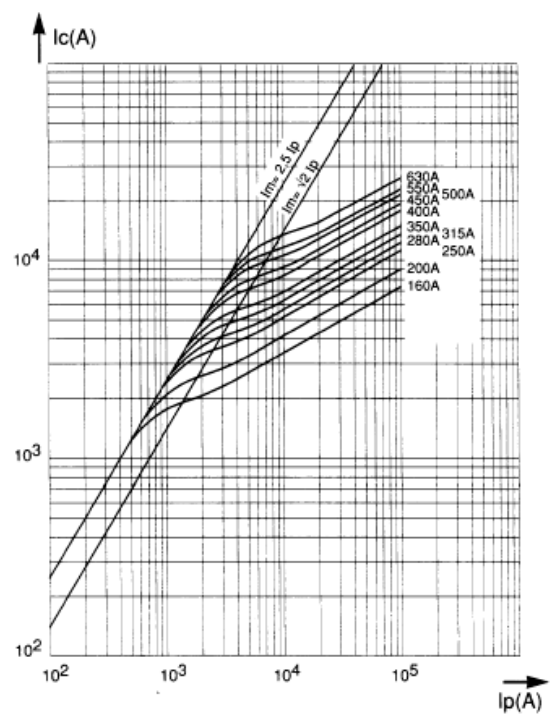

**Size 2**

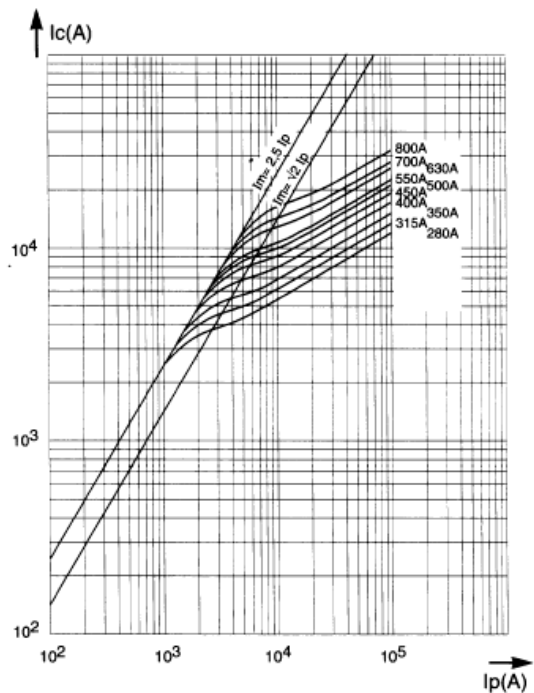

**Size 3**

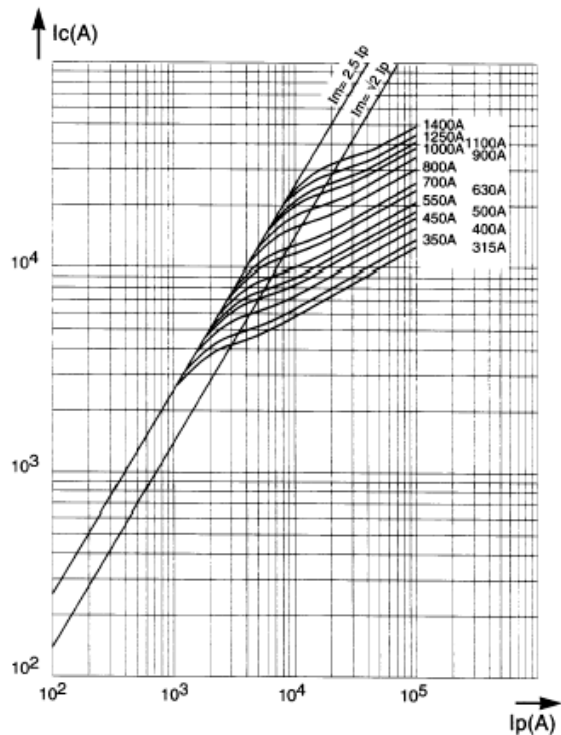

**Corrective Factor – Peak Arc Voltage:**

**Multiplier Coefficient:**

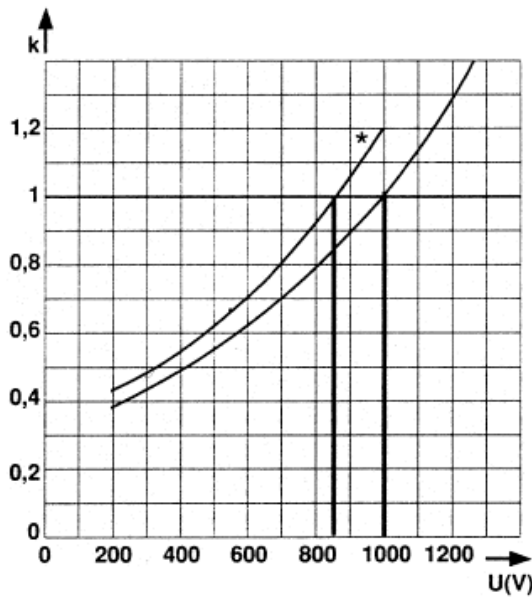

**Arc Voltage:**

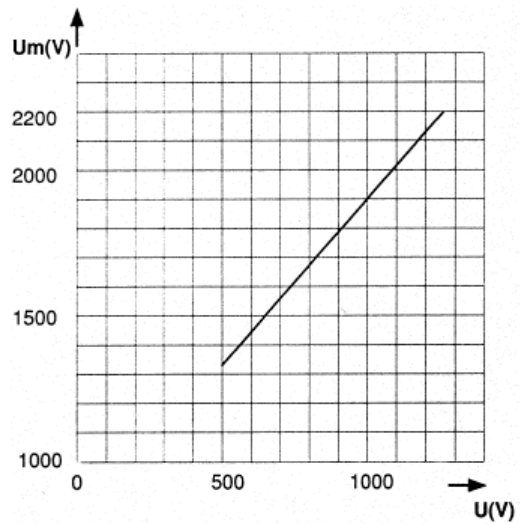

The above Mean curve shows variation of total  $I^2t$  ( $I^2t_t$ ) and total operating time  $T_t$  in accordance with working voltage  $U$ .

Curve indicating peak arc voltage  $U_m$  which may appear across fuse terminals as a function of working voltage  $U$  @  $\cos \varphi = 0.15$

**Dissipated Power:**

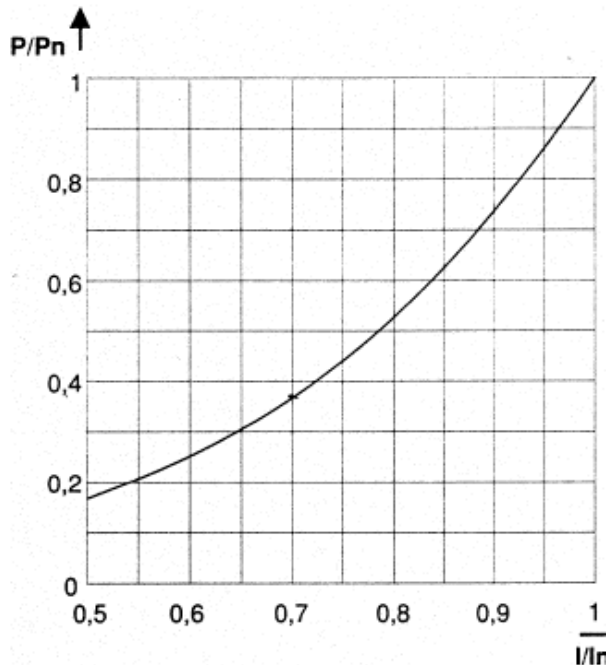

Curve enabling calculation of dissipated power  $P$  by a fuse rated  $I_N$ , as a function of the RMS current  $I$ , in multiples of  $I_N$ , in a steady state.

**Outline Drawing & Ordering Information:**

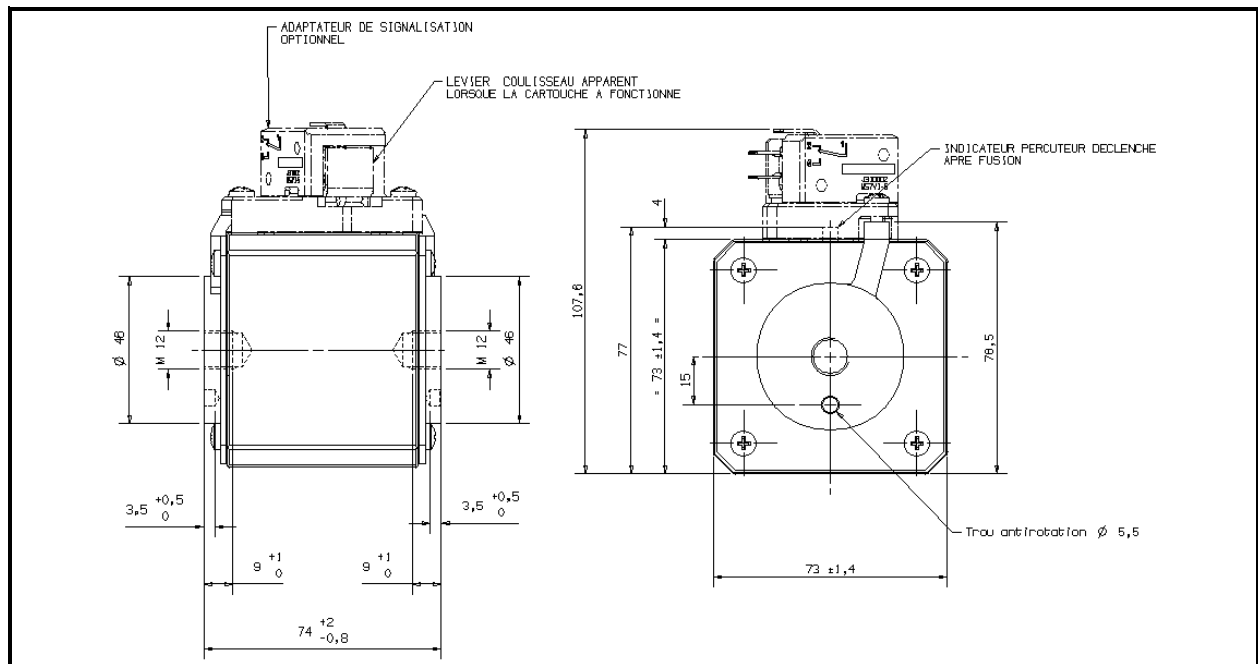

**Dimensions (mm)**

Size	A	B	C	D	M	N	E	d	G	P	Weight
0	40	46.5	82	26	22	27	74	M8	9	6	350g
1	51	56.5	91	30	19	24	74	M8	9	9	520g
2	60	65.5	100	38 (* 42)	19	39	74	M10	15	9	760 / 800g*
3	74.5	79.5	114	46 (* 52)	24	39	74	M12	15	9	1130g / 1250g*

(\* ) size 2 from 900A and size 3 from 1250A

**ORDERING INFORMATION**

(Please quote code as below)

Voltage Rating (V)	Type	Size	Fixing	Current Rating (A)	Indicator
600 – 1250V	UR	0, 1, 2, 3	S	0063 – 1800A	B

Order code: e.g. 125UR3S0450B = 1250V, French Standard End Contact, Size 3, 450A fuse with Button Indicator

**IXYS Semiconductor GmbH**  
 Edisonstraße 15  
 D-68623 Lampertheim  
 Tel: +49 6206 503-0  
 Fax: +49 6206 503-627  
 E-mail: [marcom@ixys.de](mailto:marcom@ixys.de)

**WESTCODE**  
 An IXYS Company

**Westcode Semiconductors Ltd**  
 Langley Park Way Langley Park  
 Chippenham Wiltshire SN15 1GE  
 Tel: +44 (0)1249 444524  
 Fax: +44 (0)1249 659448  
 E-mail: [WSL.sales@westcode.com](mailto:WSL.sales@westcode.com)

**IXYS Corporation**  
 3540 Bassett Street  
 Santa Clara CA 95054 USA  
 Tel: +1 (408) 982 0700  
 Fax: +1 (408) 496 0670  
 E-mail: [sales@ixys.com](mailto:sales@ixys.com)

[www.westcode.com](http://www.westcode.com)

[www.ixys.com](http://www.ixys.com)

**Westcode Semiconductors Inc**  
 3270 Cherry Avenue  
 Long Beach CA 90807 USA  
 Tel: +1 (562) 595 6971  
 Fax: +1 (562) 595 8182  
 E-mail: [WSI.sales@westcode.com](mailto:WSI.sales@westcode.com)

The information contained herein is confidential and is protected by Copyright. The information may not be used or disclosed except with the written permission of and in the manner permitted by the proprietors Westcode Semiconductors Ltd.

© Westcode Semiconductors Ltd.

In the interest of product improvement, Westcode reserves the right to change specifications at any time without prior notice.

# WESTCODE

An IXYS Company

Date:- 18 Mar, 2005

Data Sheet Issue:- 1

## Ultra Rapid Semiconductor Protection Fuse European Square Body Fuses



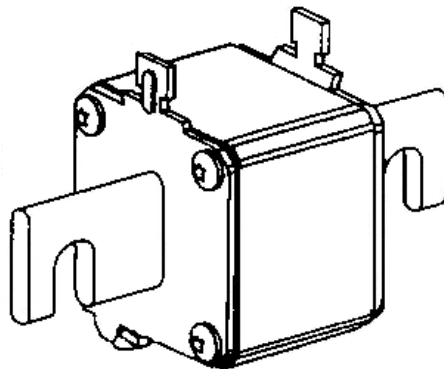







French Standard Blade Contact  
Voltage Rating 500V to 690V  
Current Ratings 63A to 1400A  
aR Characteristics  
Sizes 0, 1, 2, 3













### **Key Features:**

- ❖ Extremely high interrupting rating fuses for the protection of power semiconductors in accordance with IEC Standard 60269.1 and 4.
- ❖ Exceptionally low  $I^2t$ , power losses
- ❖ Highly reliable low voltage trip indicator system which conforms to UL, IEC, DIN and VDE standards
- ❖ Non Magnetic construction
- ❖ Increased technical performance gives higher ratings and a reduction in volume and weight
- ❖ Microswitch system reference : MS 3V 1-5
- ❖ Fuse holder type : SI DIN 80









**Main Characteristics:**

Size	Voltage	Ref:		Current rating $I_N$ (A)	Pre-arcing $I^2t @ 1 ms$ $I^2t_p$ (kA <sup>2</sup> s)	Total Clearing $I^2t @ U_N$ (kA <sup>2</sup> s)	Watt Losses		Tested Interrupting rating
							$0.8I_N$	$I_N$	
0	690V	069UF0A0063B		63	0.2	1.1	7.5	14	200kA @660V (IEC) 170kA @700V (USA)
		069UF0A0080B		80	0.33	1.75	9.5	19	
		069UF0A0100B		100	0.47	2.5	13	26	
		069UF0A0125B		125	0.85	4.5	15	30	
		069UF0A0160B		160	1.6	8.5	18.5	37	
		069UF0A0200B		200	3	15.5	21.5	43	
		069UF0A0250B		250	5.8	30	25	50	
		069UF0A0315B		315	12	62	22.5	55	
		069UF0A0350B		350	15.5	80	30	60	
		069UF0A0400B		400	23	120	32.5	65	

Notes: Minimum operating voltage for integrated trip indicator = 20V  
Microswitch reference : MS 3V 1-5











Size	Voltage	Ref:		Current rating $I_N$ (A)	Pre-arcing $I^2t @ 1 ms$ $I^2t_p$ (kA <sup>2</sup> s)	Total Clearing $I^2t @ U_N$ (kA <sup>2</sup> s)	Watt Losses		Tested Interrupting rating
							$0.8I_N$	$I_N$	
1	690V	069UF1B0200B		200	2.6	13.5	22.5	45	200kA @660V (IEC) 170kA @700V (USA)
		069UF1B0250B		250	4.7	25	25.5	52	
		069UF1B0315B		315	7.5	40	32.5	65	
		069UF1B0350B		350	10.5	55	33.5	67	
		069UF1B0400B		400	19	100	34	68	
		069UF1B0450B		450	26.5	140	35	70	
		069UF1B0500B		500	37	195	36	72	
		069UF1B0550B		550	52	280	37.5	75	
		069UF1B0630B		630	75	390	42.5	85	
		069UF1B0800B		800	140	800	52.5	105	

Notes: Minimum operating voltage for integrated trip indicator = 20V  
Microswitch reference : MS 3V 1-5

Size	Voltage	Ref:		Current rating $I_N$ (A)	Pre-arcing $I^2t @ 1 ms$ $I^2t_p$ (kA <sup>2</sup> s)	Total Clearing $I^2t @ U_N$ (kA <sup>2</sup> s)	Watt Losses		Tested Interrupting rating
							$0.8I_N$	$I_N$	
2	690V	069UF2B0400B		400	15	80	32.5	75	200kA @660V (IEC) 170kA @700V (USA)
		069UF2B0450B		450	20	115	40	80	
		069UF2B0500B		500	28	145	45	90	
		069UF2B0550B		550	37	195	47.5	95	
		069UF2B0630B		630	54	280	52.5	105	
		069UF2B0700B		700	76	400	55	110	
		069UF2B0800B		800	115	600	60	120	
		069UF2B0900B		900	170	900	62.5	125	

Notes: Minimum operating voltage for integrated trip indicator = 20V  
Microswitch reference : MS 3V 1-5

**Main Characteristics continued.....**

Size	Voltage	Ref:		Current rating I <sub>N</sub> (A)	Pre-arcing I <sup>2</sup> t @ 1 ms I <sup>2</sup> t <sub>p</sub> (kA <sup>2</sup> s)	Total Clearing I <sup>2</sup> t @ U <sub>N</sub> (kA <sup>2</sup> s)	Watt Losses		Tested Interrupting rating
							0.8I <sub>N</sub>	I <sub>N</sub>	
3	690V	069UF3B0500B		500	19	100	52.5	105	200kA @660V (IEC)  170kA @700V (USA)
		069UF3B0550B		550	27	140	55	110	
		069UF3B0630B		630	40	210	60	120	
		069UF3B0700B		700	55	300	62.5	125	
		069UF3B0800B		800	95	490	65	130	
		069UF3B0900B		900	135	700	67.5	135	
		069UF3B1000B		1000	170	900	77.5	155	
		069UF3B1100B		1100	240	1260	80	160	
		069UF3B1250B		1250	350	1850	90	180	
		069UF3B1400B		1400	480	2500	100	200	

Notes: Minimum operating voltage for integrated trip indicator = 20V  
 Microswitch reference : MS 3V 1-5

**Electrical Characteristics:**

**Times vs current characteristics**

The curves shown on page 4 indicate the pre-arcing time for each rated current as a function of RMS value of pre-arcing current I:

- Tolerances on this current ± 8%
- Beyond 30 sec or 10 sec, small overloads must be eliminated by another device.

Curve CC' represents the maximum times taken by the associated device to clear small overloads; only its horizontal line is represented.

Its oblique line must be plotted according to sketch in top right corner:

- The intersection of the fuse and CC' curves indicates the minimum breaking current I<sub>pm</sub> of the fuse.



**Times vs current characteristics**

**Size 0**

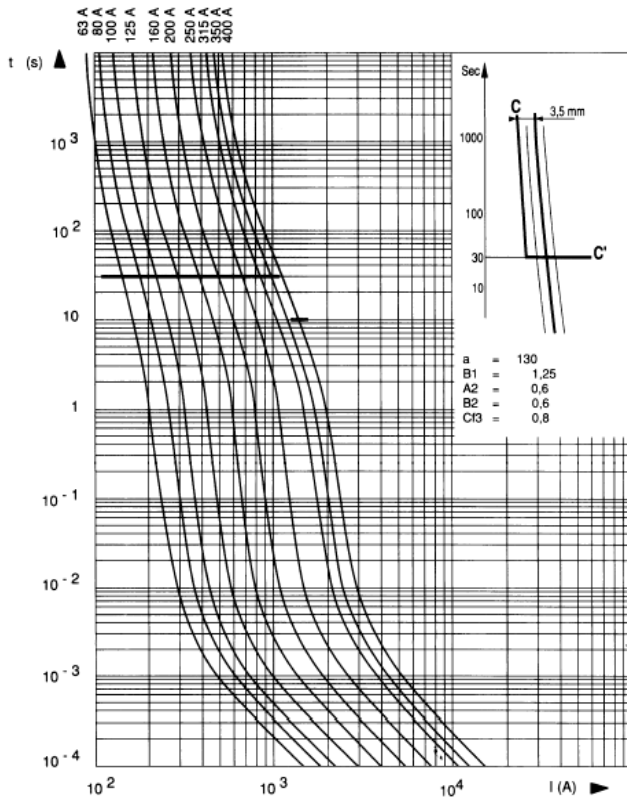

**Size 1**

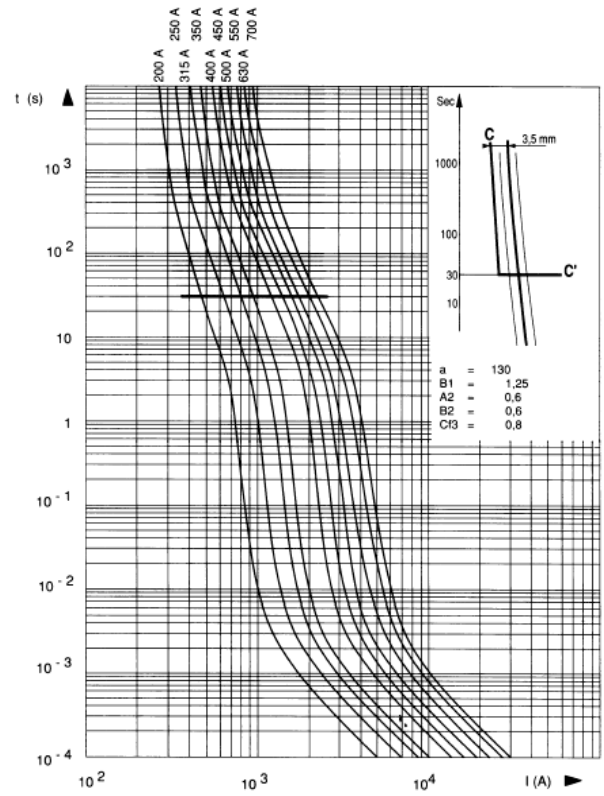

**Size 2**

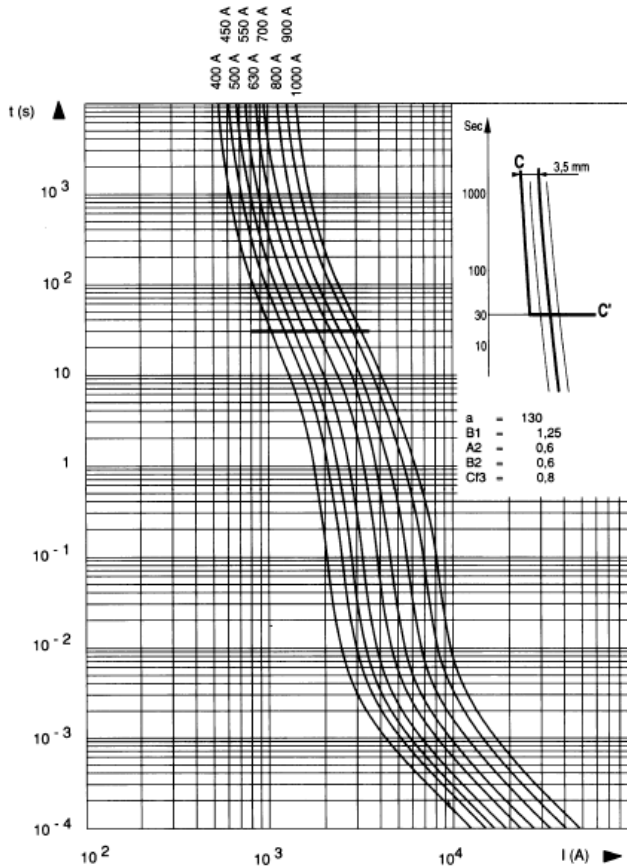

**Size 3**

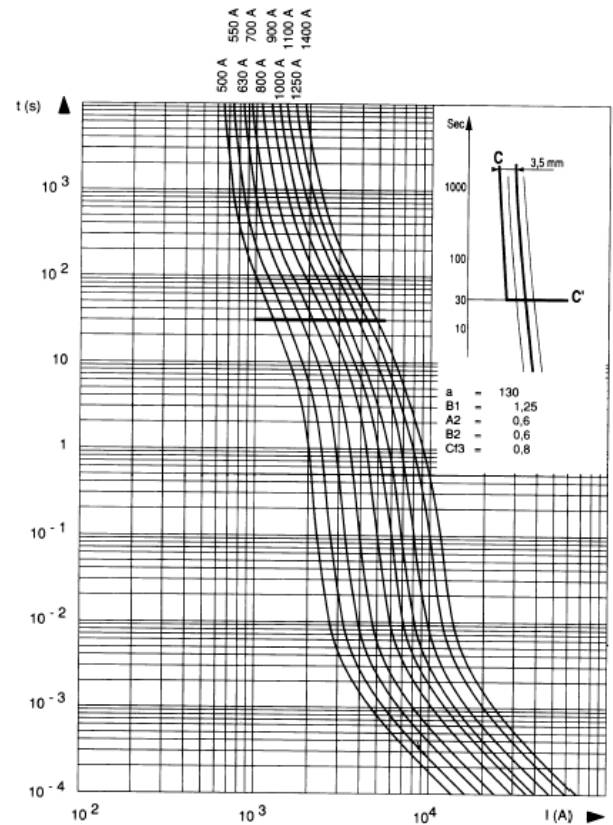

**Total clearing I<sup>2</sup>T:**

The horizontal curves given below indicated the maximum values of total operating I<sup>2</sup>t (I<sup>2</sup>t<sub>t</sub>) as a function of prospective current I<sub>p</sub> @ 660V, cosφ = 0.15. Oblique lines indicate the corresponding total operating time T<sub>t</sub>, with pre-arcing time in brackets.

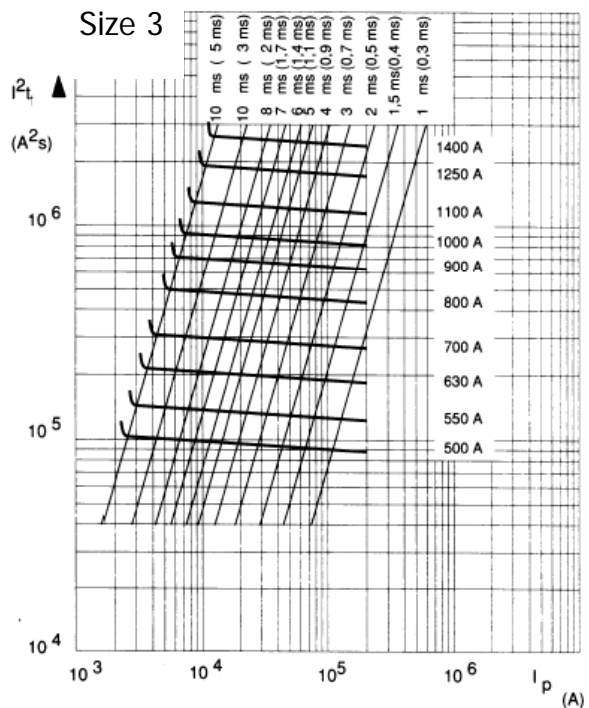
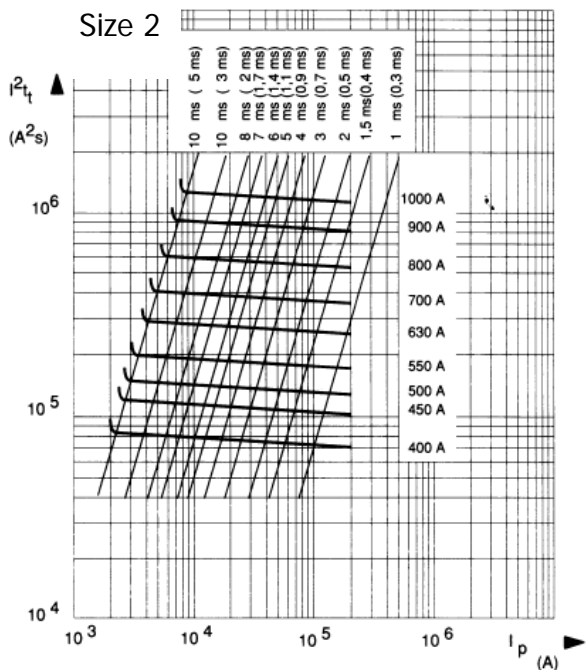
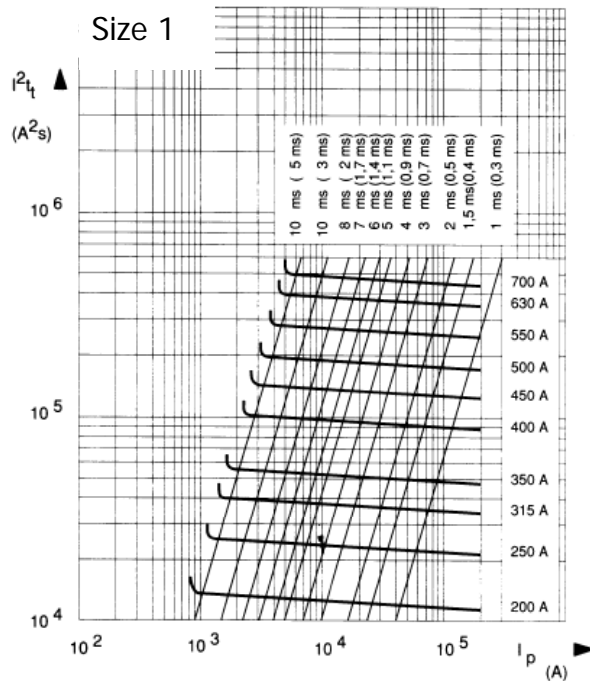
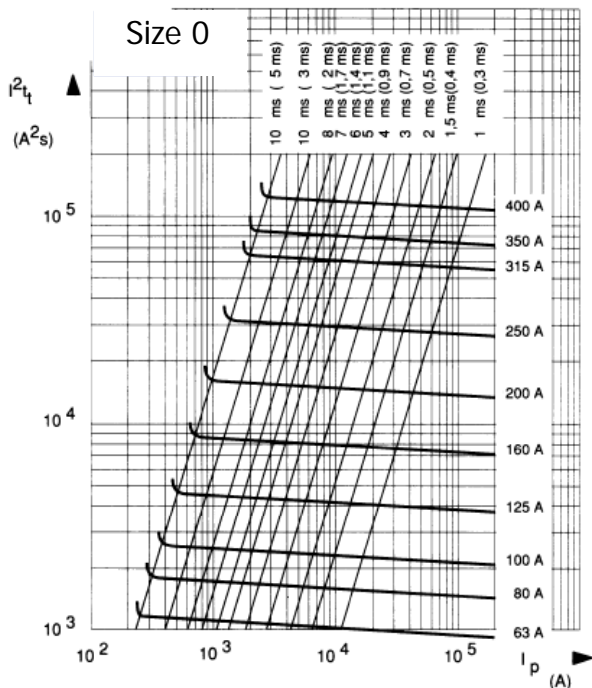

**Cut off Characteristics:**

The curves below indicate, for each rated current, the peak value  $I_c$  that the current may reach as a function of the prospective fault current  $I_p$ .

**Size 0**

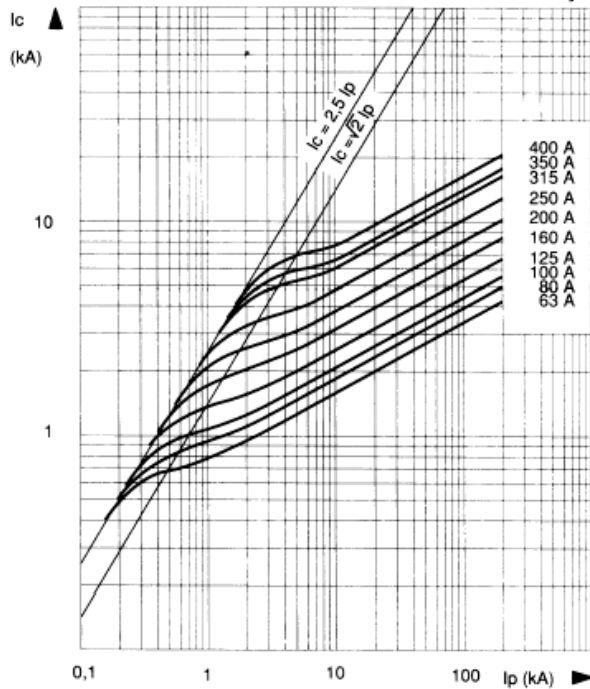

**Size 1**

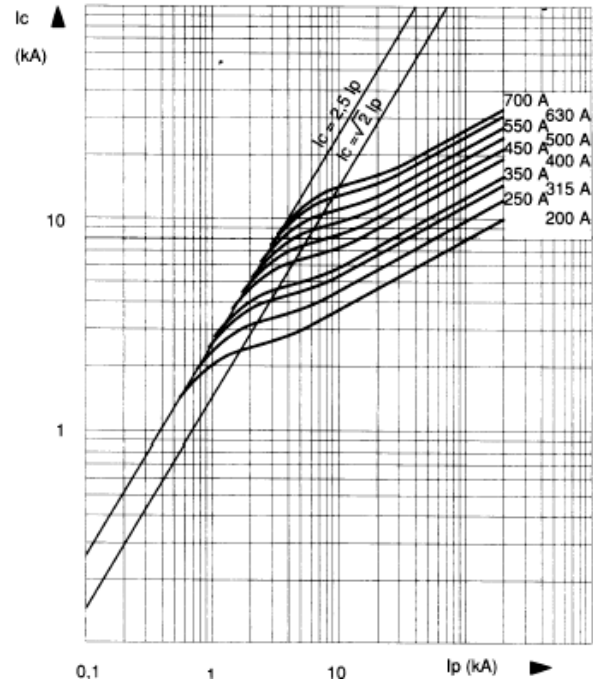

**Size 2**

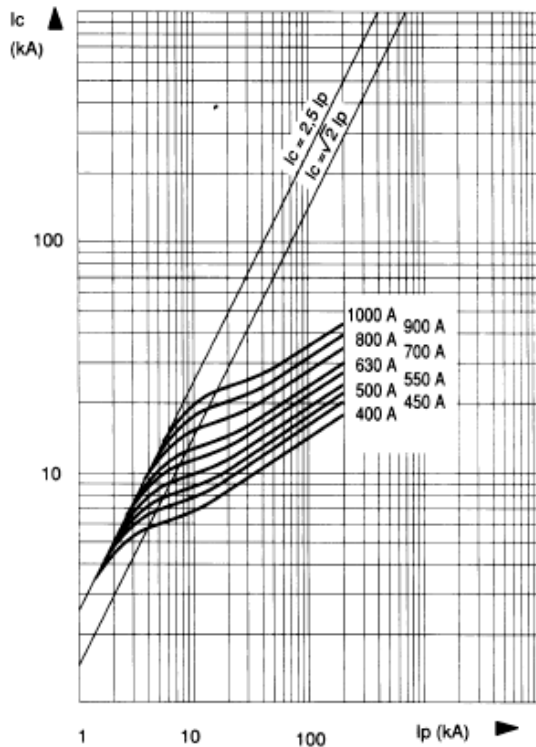

**Size 3**

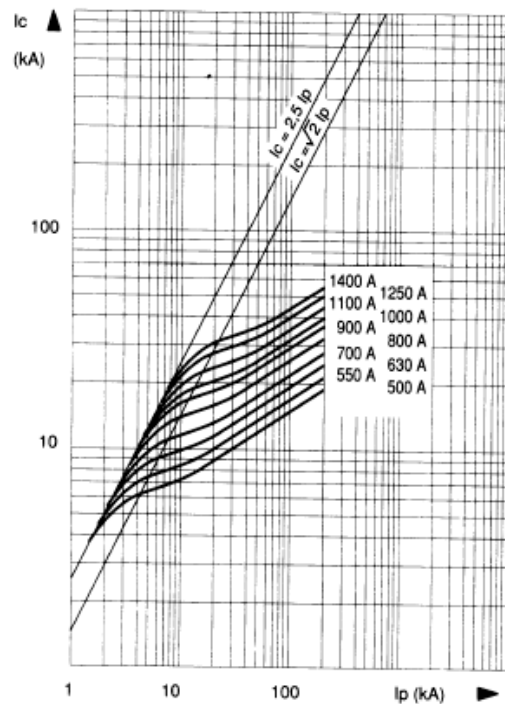

### I<sup>2</sup>t Multiplier Coefficient

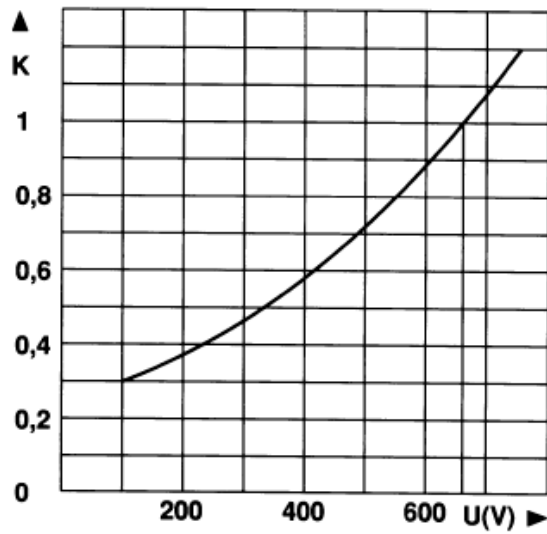

The above Mean curve shows variation of total clearing time ( $I^2t_i$ ) and total operating time  $T_i$  in accordance with working voltage U.

### Peak Arc Voltage

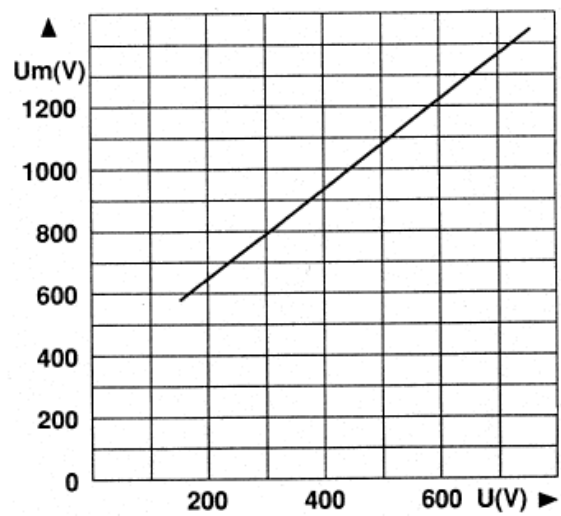

Curve indicating peak arc voltage  $U_m$  which may appear across fuse terminals as a function of working voltage U @  $\cos \varphi = 0.15$ .

### Dissipated Power

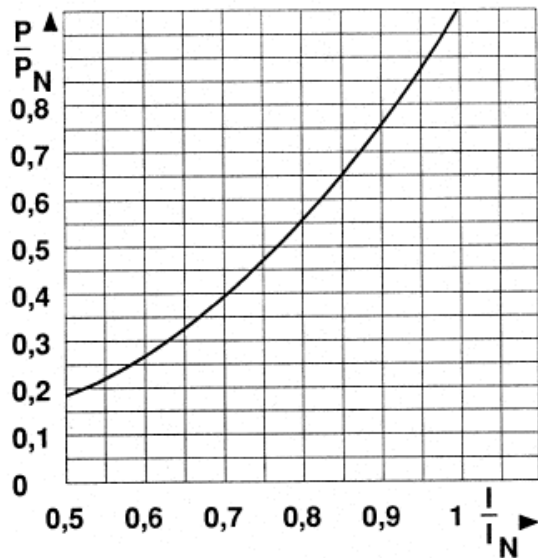

Curve enabling calculation of dissipated power P by a fuse rated  $I_N$ , as a function of the RMS current I, in multiples of  $I_N$  in a steady state.

**Outline Drawing & Ordering Information:**

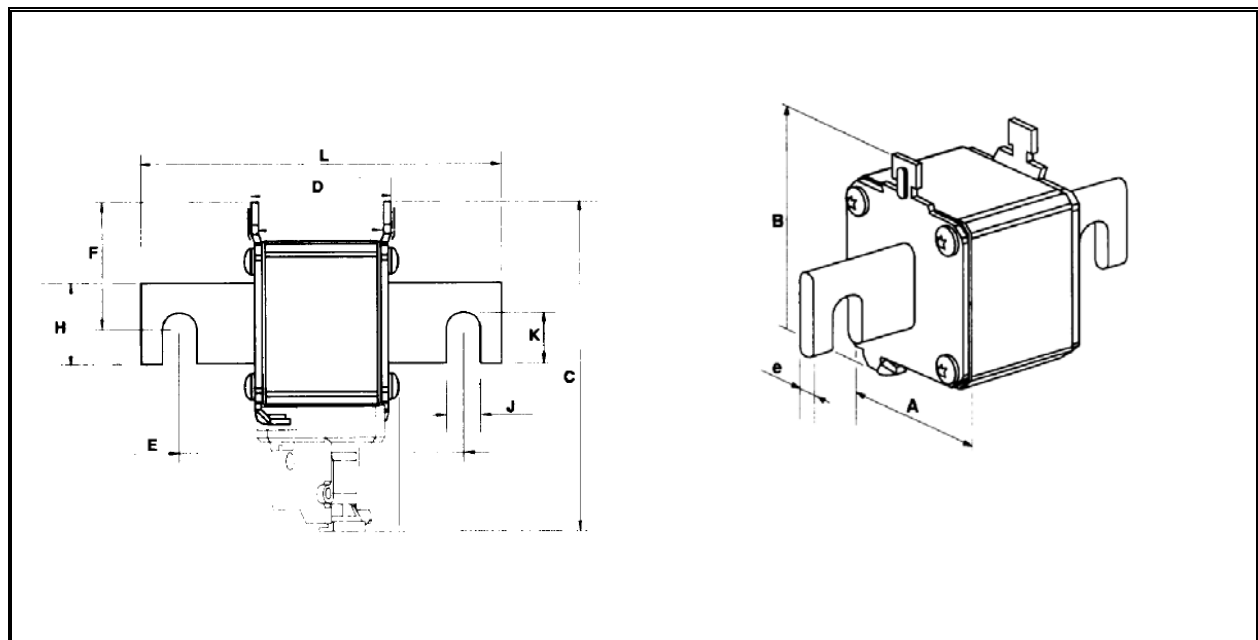

**Dimensions (mm)**

Size	A	B	C	D	E	L	F	H	J	K	e	Weight
0	40	62	96	44.6	76.6	100	38	18	9	11	6	290g
1	51	69	103	44.6	86.6	110	39	25	10.5	16	6	430g
2	60	78	112	44.6	91	126	43	32	13	21.2	6	590g
3	74.5	92.5	127	44.6	91	126	57	40	13	19.5	6	860g

**ORDERING INFORMATION**

(Please quote code as below)

Voltage Rating (V)	Type	Sizes	Fixing	Current Ratings	Indicator
690	UF	0, 1, 2, 3	A or B	0063 – 1400	B

Order code: e.g. **069UF3B0315B** = 690V, French Standard Blade, Size 3, 90mm, 315A with button indicator

**IXYS Semiconductor GmbH**  
 Edisonstraße 15  
 D-68623 Lampertheim  
 Tel: +49 6206 503-0  
 Fax: +49 6206 503-627  
 E-mail: [marcom@ixys.de](mailto:marcom@ixys.de)



An IXYS Company

**Westcode Semiconductors Ltd**  
 Langley Park Way Langley Park  
 Chippenham Wiltshire SN15 1GE  
 Tel: +44 (0)1249 444524  
 Fax: +44 (0)1249 659448  
 E-mail: [WSL.sales@westcode.com](mailto:WSL.sales@westcode.com)

**IXYS Corporation**  
 3540 Bassett Street  
 Santa Clara CA 95054 USA  
 Tel: +1 (408) 982 0700  
 Fax: +1 (408) 496 0670  
 E-mail: [sales@ixys.com](mailto:sales@ixys.com)

[www.westcode.com](http://www.westcode.com)

[www.ixys.com](http://www.ixys.com)

**Westcode Semiconductors Inc**  
 3270 Cherry Avenue  
 Long Beach CA 90807 USA  
 Tel: +1 (562) 595 6971  
 Fax: +1 (562) 595 8182  
 E-mail: [WSI.sales@westcode.com](mailto:WSI.sales@westcode.com)

The information contained herein is confidential and is protected by Copyright. The information may not be used or disclosed except with the written permission of and in the manner permitted by the proprietors Westcode Semiconductors Ltd.

© Westcode Semiconductors Ltd.

In the interest of product improvement, Westcode reserves the right to change specifications at any time without prior notice.

## Ultra Rapid Semiconductor Protection Fuse French Ferrule Type













French Ferrule Fuses  
Voltage Ratings 660V to 700V  
Current Ratings from 1A to 32A  
Size 10x38



### Key Features:

- ❖ Extremely high interrupting rating fuses protection of power semiconductors as per IEC Standard 60269.1 and 4.
- ❖ 660V to 690V voltage rating complying with IEC 33
- ❖ Non Magnetic construction
- ❖ gR Characteristics with current ratings from 1A to 32A in accordance with VDE 636-23
  - Clearing all overloads
  - Improved safety and protection
  - Enabling selective co-ordination among all distribution circuit fuses
- ❖ All models without trip-indicator
- ❖ gRC fuses from 8A to 50A are 700VAC-DC UL recognised

**Main Characteristics:**

Size	Voltage $U_N$ (V)	Ref:		Current rating $I_N$ (A)	Pre-arcing $I^2t @ 1\text{ ms}$ $I^2t_p$ (kA <sup>2</sup> s)	Total Clearing $I^2t @ U_N$ (kA <sup>2</sup> s)	Power Losses		Tested Interrupting rating
							$0.8I_N$	$I_N$	
10x38	690V	F070A001N		1	0.066	0.21	0.57	1	160kA @690V
		F070A002N		2	0,42	1.3	1.1	2	
		F070A003N		3	1.55	4.6	1.25	2.3	
		F070A004N		4	4	12	1.35	2.6	
		F070A005N		5	8.6	25	1.4	2.7	
		F070A006N		6	15	44	1.5	2.9	
		F070A008N		8	3,3	33	1.35	2.4	
		F070A010N		10	5,4	55	1.85	3.4	
		F070A016N		16	16	145	2.3	4.1	
		F070A020N		20	30	250	2.4	4.3	
		F070A025N		25	58	470	2.7	4.7	
		F070A030N		30	96	740	2.9	5	
		F070A032N		32	96	740	2.9	5	

Notes: Minimum operating voltage for integrated trip indicator = 20V

**Electrical Characteristics:**

**Times vs current characteristics**

The following curves indicate, for each rated current, pre-arcing time as a function of RMS value of pre-arcing current I.

Tolerances on this current:  $\pm 10\%$  = ratings from 1 to 6A  
 $\pm 9\%$  = ratings from 8 to 30-32A

Fuse with gR characteristics can eliminate all overloads. They do not show any minimum breaking capacity but limit currents of non-operation or operation in compliance with standard VDE 636/23.

**I ≤ 6**

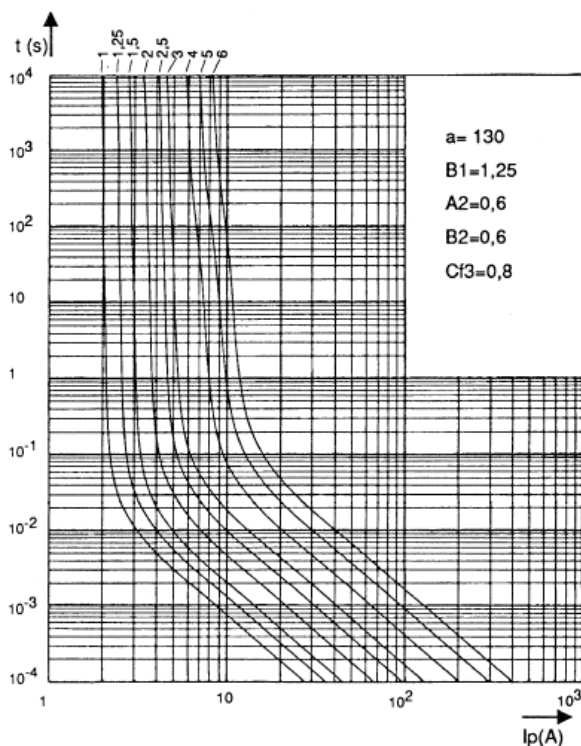

**I ≥ 8**

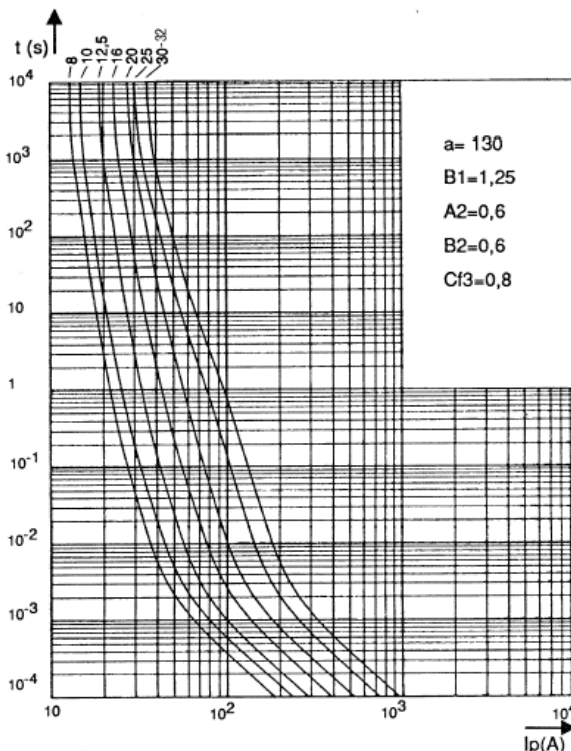

**Cut off Characteristics:**

The curves below indicate, for each rated current, the peak value  $I_c$  that the current may reach as a function of prospective fault current  $I_p$ .

**I ≤ 6**

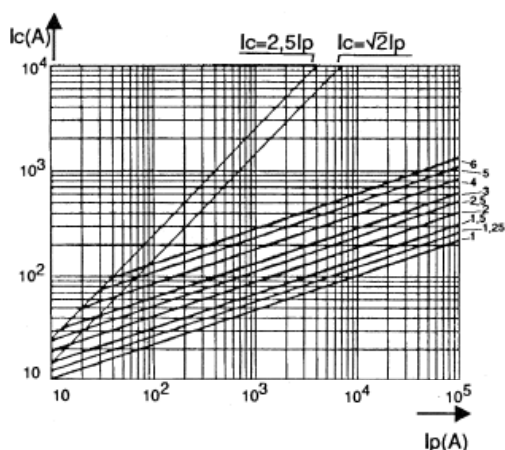

**I ≥ 8**

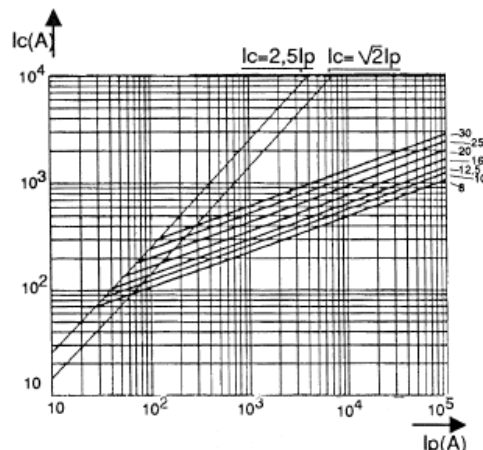



**Arc Voltage:**

$I \leq 6$

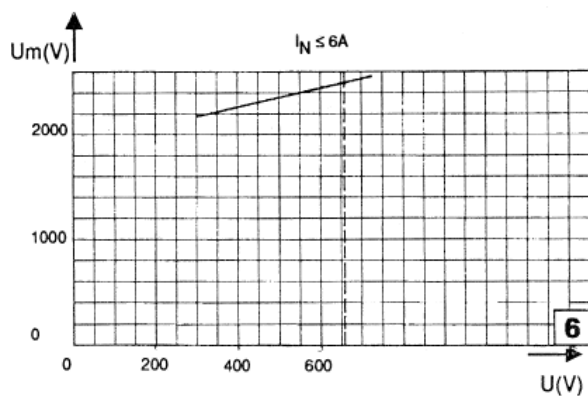

$I \geq 8$

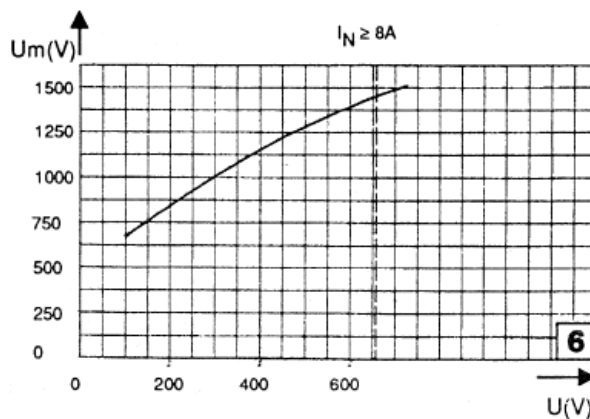

**Multiplier Coefficient:**

$I \leq 6$

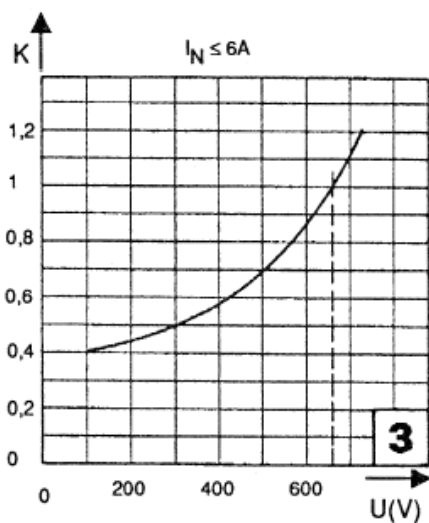

$I \geq 8$

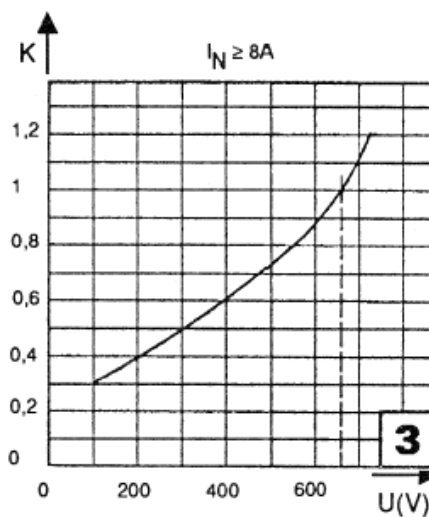

**Outline Drawing & Ordering Information**

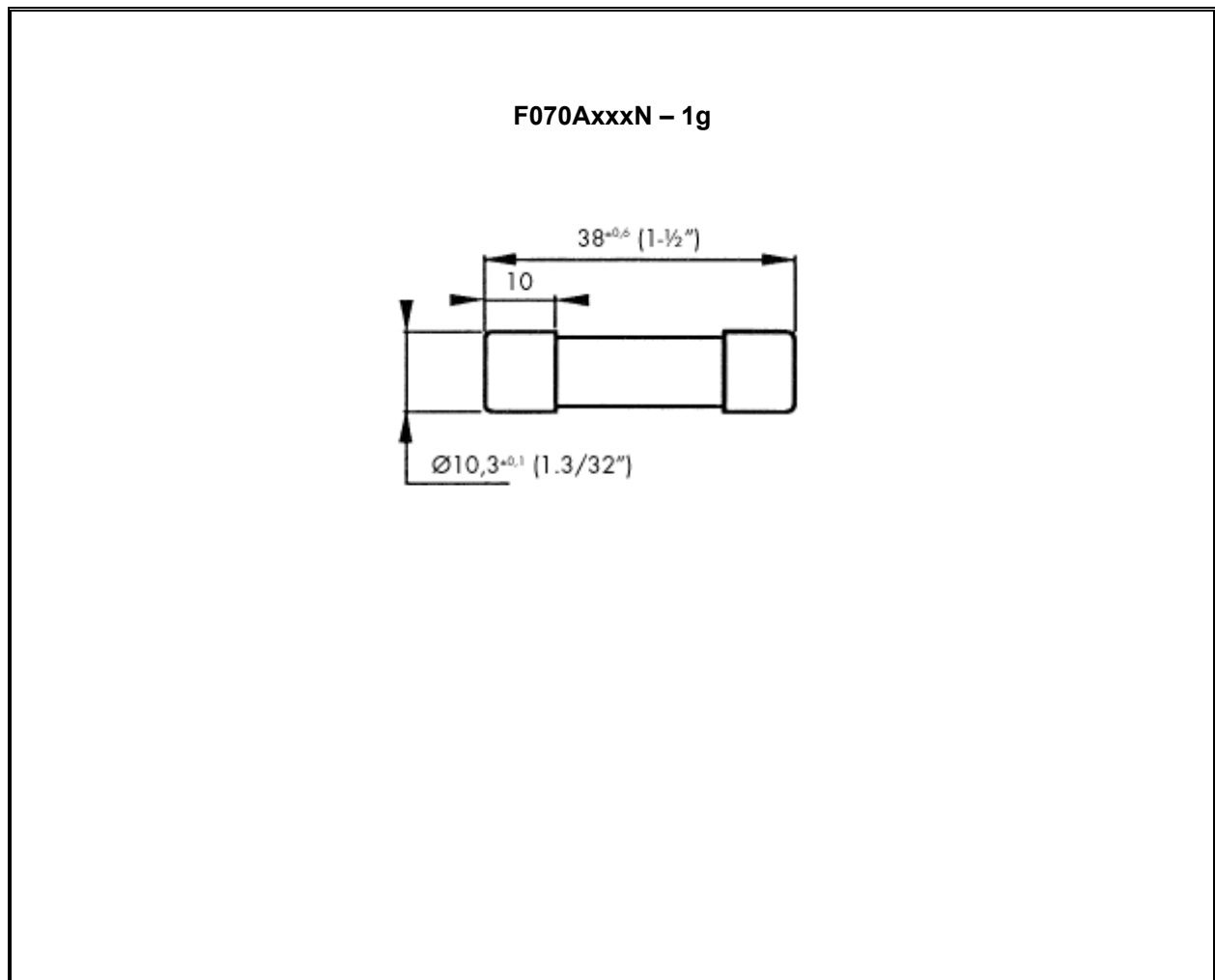

**ORDERING INFORMATION**

(Please quote code as below)

Type	Voltage Rating (V)	Size	Current Rating (A)	Trip Indicator
F	700	A	1 - 32	N

Order code: e.g. **F070A0025N** = French Ferrule type fuse, 700V, 10x38, 25A without trip indicator

**IXYS Semiconductor GmbH**  
 Edisonstraße 15  
 D-68623 Lampertheim  
 Tel: +49 6206 503-0  
 Fax: +49 6206 503-627  
 E-mail: [marcom@ixys.de](mailto:marcom@ixys.de)

**WESTCODE**

An  IXYS Company

**Westcode Semiconductors Ltd**  
 Langley Park Way Langley Park  
 Chippenham Wiltshire SN15 1GE  
 Tel: +44 (0)1249 444524  
 Fax: +44 (0)1249 659448  
 E-mail: [WSL.sales@westcode.com](mailto:WSL.sales@westcode.com)

**IXYS Corporation**  
 3540 Bassett Street  
 Santa Clara CA 95054 USA  
 Tel: +1 (408) 982 0700  
 Fax: +1 (408) 496 0670  
 E-mail: [sales@ixys.com](mailto:sales@ixys.com)

[www.westcode.com](http://www.westcode.com)

[www.ixys.com](http://www.ixys.com)

**Westcode Semiconductors Inc**  
 3270 Cherry Avenue  
 Long Beach CA 90807 USA  
 Tel: +1 (562) 595 6971  
 Fax: +1 (562) 595 8182  
 E-mail: [WSI.sales@westcode.com](mailto:WSI.sales@westcode.com)

The information contained herein is confidential and is protected by Copyright. The information may not be used or disclosed except with the written permission of and in the manner permitted by the proprietors Westcode Semiconductors Ltd.

© Westcode Semiconductors Ltd.

In the interest of product improvement, Westcode reserves the right to change specifications at any time without prior notice.

# WESTCODE

An IXYS Company

Date:- 17 Mar, 2005

Data Sheet Issue:- 1

## Ultra Rapid Semiconductor Protection Fuse French Ferrule Type

French Ferrule Fuses  
Voltage Rating 700V  
Current Rating from 1A to 50A  
Size 14x51



### Key Features:

- ❖ Extremely high interrupting rating fuses protection of power semiconductors as per IEC Standard 60269.1 and 4.
- ❖ 660V to 690V voltage rating complying with IEC 33
- ❖ Non Magnetic construction
- ❖ gR Characteristics with current ratings from 1A to 32A in accordance with VDE 636-23
  - Clearing all overloads
  - Improved safety and protection
  - Enabling selective co-ordination among all distribution circuit fuses
- ❖ All models available with or without trip-indicator
- ❖ gRC fuses from 8A to 50A are 700VAC-DC UL recognised

**Main Characteristics:**

Size	Voltage U <sub>N</sub> (V)	Ref:		Current rating I <sub>N</sub> (A)	Pre-arcing I <sup>2</sup> <sub>t</sub> @ 1 ms I <sup>2</sup> <sub>tp</sub> (kA <sup>2</sup> s)	Total Clearing I <sup>2</sup> <sub>t</sub> @ U <sub>N</sub> (kA <sup>2</sup> s)	Watt Losses		Tested Interrupting rating
							0.8I <sub>N</sub>	I <sub>N</sub>	
<b>14x51 without trip indicator</b>	690	F070B001N		1	0.31	1.4	0.17	0.35	100kA @ 690V
		F070B002N		2	1	4.3	0.33	0.60	
		F070B004N		4	6.7	30	0.77	1.4	
		F070B006N		6	1.4	19	1.3	2.5	
		F070B008N		8	2.4	30	1.5	3.0	
		F070B010N		10	4.3	44	1.75	3.3	
		F070B012N		12	5.4	65	2.25	4.25	
		F070B016N		16	13	110	2.5	4.8	
		F070B020N		20	27	175	2.75	5.25	
		F070B025N		25	53	300	3.0	5.8	
		F070B032N		32	97	550	3.5	7.0	
		F070B040N		40	210	1210	4.5	8.8	
F070B050N		50	390	2250	5.0	10			

Size	Voltage U <sub>N</sub> (V)	Ref:		Current rating I <sub>N</sub> (A)	Pre-arcing I <sup>2</sup> <sub>t</sub> @ 1 ms I <sup>2</sup> <sub>tp</sub> (kA <sup>2</sup> s)	Total Clearing I <sup>2</sup> <sub>t</sub> @ U <sub>N</sub> (kA <sup>2</sup> s)	Watt Losses		Tested Interrupting rating
							0.8I <sub>N</sub>	I <sub>N</sub>	
<b>14x51 with Trip indicator</b>	690	F070B001S		1	0.8	3.5	0.17	0.35	100kA @ 690V
		F070B002S		2	1.5	6.7	0.33	0.60	
		F070B004S		4	7.2	33	0.77	1.4	
		F070B006S		6	1.4	19	1.3	2.5	
		F070B008S		8	2.4	30	1.5	3.0	
		F070B010S		10	4.3	44	1.75	3.3	
		F070B012S		12	5.4	65	2.25	4.25	
		F070B016S		16	13	110	2.5	4.8	
		F070B020S		20	27	175	2.75	5.25	
		F070B025S		25	53	300	3.0	5.8	
		F070B032S		32	97	550	3.5	7.0	
		F070B040S		40	210	1210	4.5	8.8	
F070B050S		50	390	2250	5.0	10			

Notes: Minimum operating voltage for integrated trip indicator = 20V

**Electrical Characteristics:**

**Times vs current characteristics**

The following curves indicate, for each rated current, pre-arcing time as a function of RMS value of pre-arcing current I.

Tolerance for mean pre-arcing current:  $\pm 10\%$  = ratings from 1, 2, 4A  
 $\pm 8\%$  = ratings from 6 to 63A

Fuses with gR characteristics can eliminate all overloads. They do not show a minimum breaking capacity but limit currents of non-operation or operation in compliance with standard VDE 636/23.

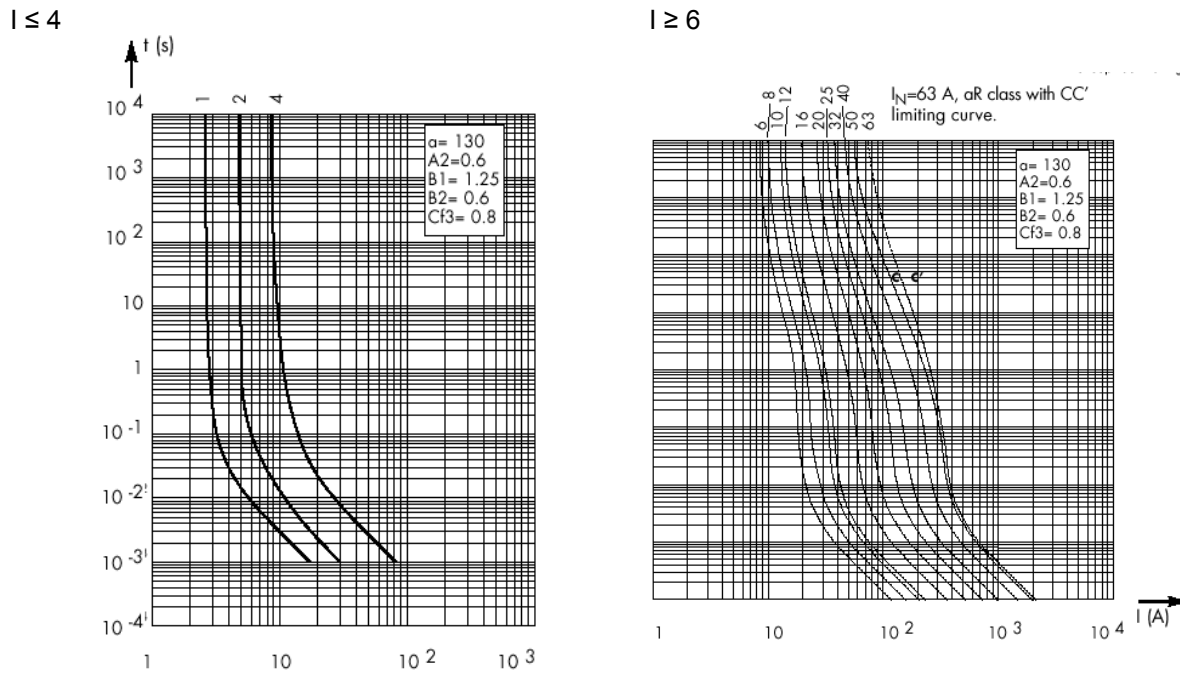

**Total clearing  $I^2t$ :**

Horizontal curves show maximum values of total clearing  $I^2t$  ( $I^2t_t$ ) for each rated current as a function of prospective current  $I_p$  @ 690V  $\cos\phi = 0.15$  (for 63A @ 600V  $\cos\phi = 0.15$ ). Oblique lines indicate total clearing duration  $Tt$ , with associated pre-arcing duration in brackets.

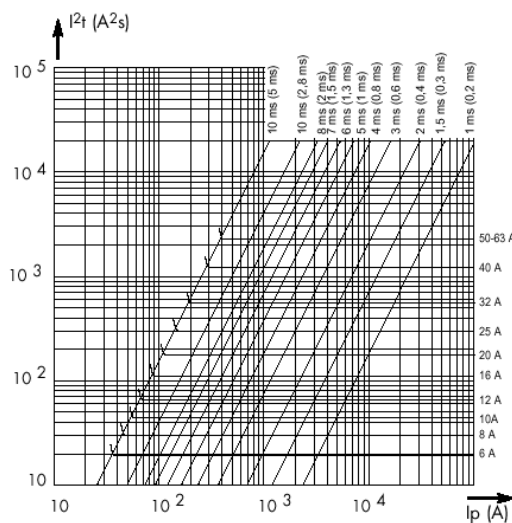

**Cut off Characteristics:**

The curves below show, for each rating, value of peak let-through current  $I_C$  as a function of available fault current  $I_p$ .

$I \leq 4$

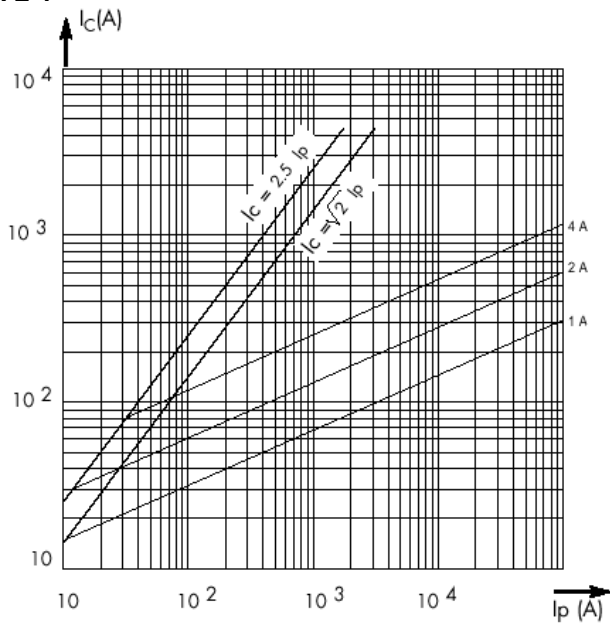

$I \geq 6$

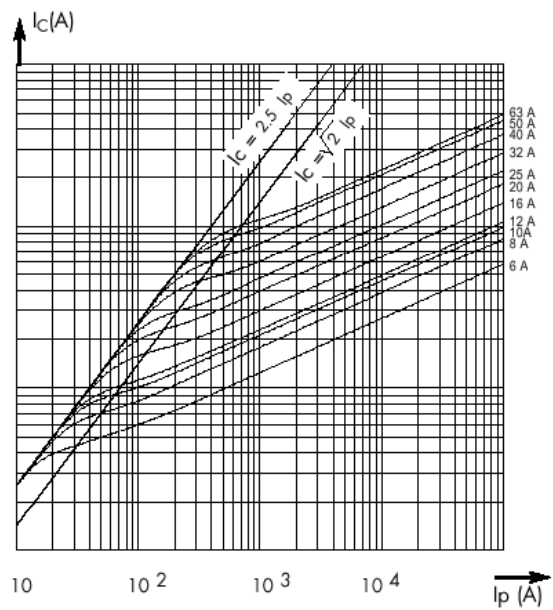

**Corrective Factor:**

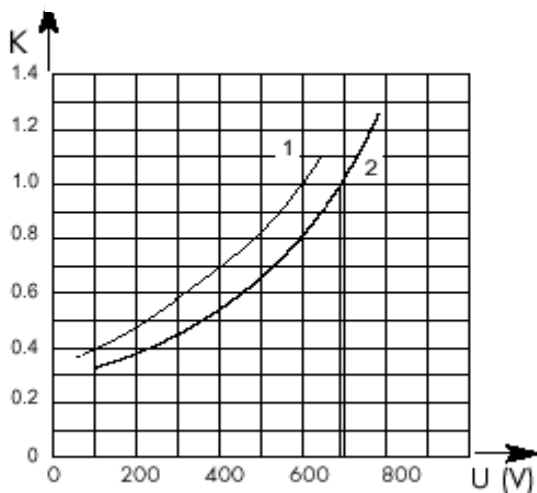

Mean curves showing variation of total clearing time ( $I^2t_t$ ) and total clearing duration  $T_t$  as a function of operating voltage  $U$ .

- (1) 63A rating – 600V
- (2) (2) 1-50A rating – 690V

**Peak Arc Voltage:**

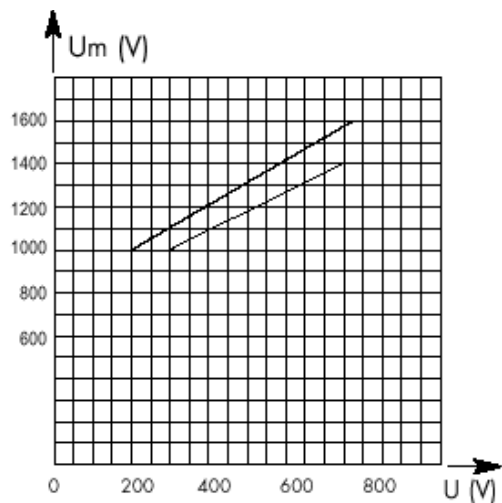

Curves showing peak value  $U_m$  of arc voltage which appears across fuse-link as a function of operating voltage  $U$  @  $\cos\phi = 0.15$ .

**Outline Drawing & Ordering Information:**

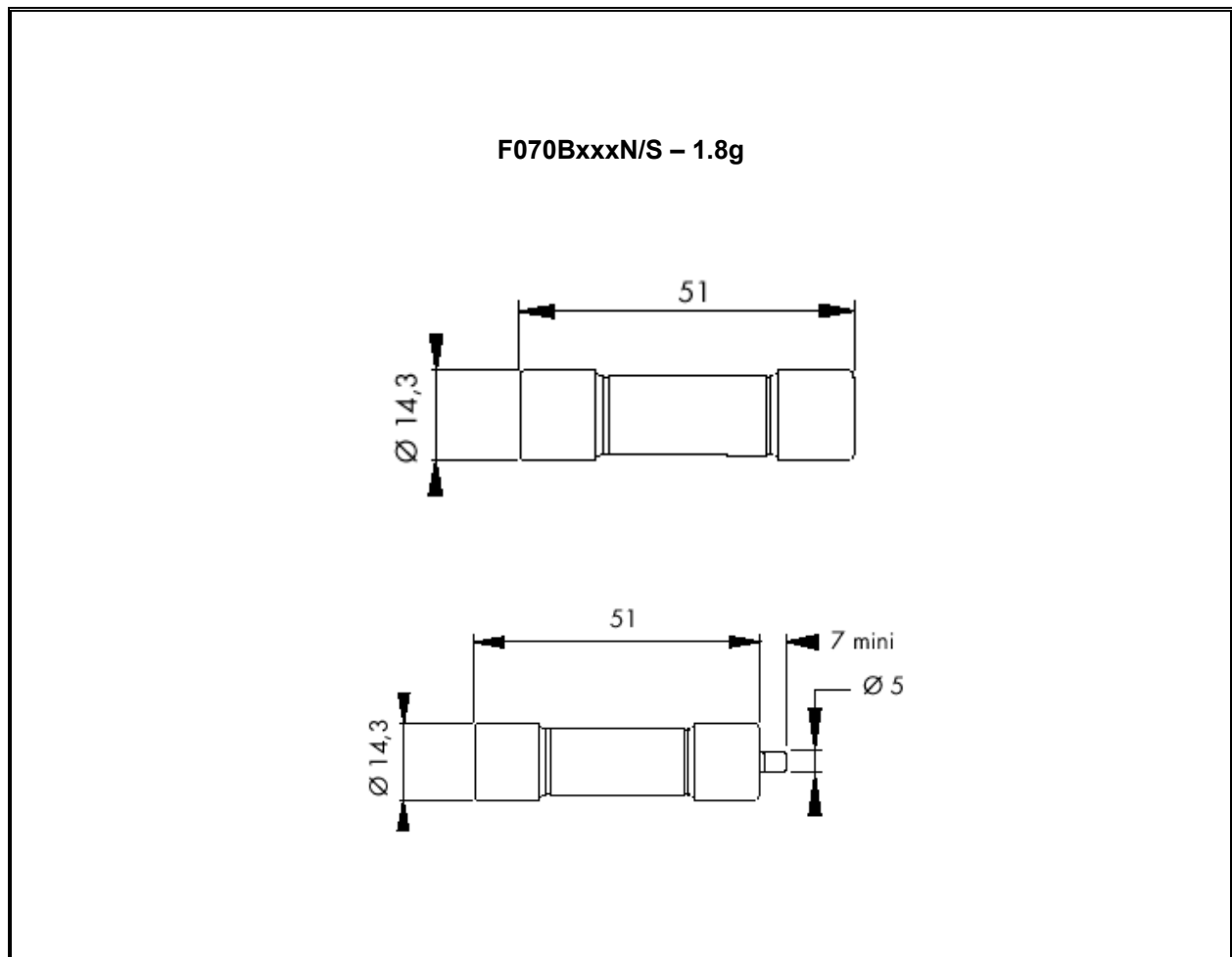

<b>ORDERING INFORMATION</b>				
(Please quote code as below)				
Size	Voltage Rating (V)	Type	Current Rating I <sub>N</sub> (A)	With (S) or without (N) indicator
14x51	700	B	001 to 050	S or N

Order code: e.g. **F070B001N** = Ferrule Type, 700V, 14mm x 51mm, 1 amp fuse without indicator.

**IXYS Semiconductor GmbH**  
 Edisonstraße 15  
 D-68623 Lampertheim  
 Tel: +49 6206 503-0  
 Fax: +49 6206 503-627  
 E-mail: [marcom@ixys.de](mailto:marcom@ixys.de)



An IXYS Company

**Westcode Semiconductors Ltd**  
 Langley Park Way Langley Park  
 Chippenham Wiltshire SN15 1GE  
 Tel: +44 (0)1249 444524  
 Fax: +44 (0)1249 659448  
 E-mail: [WSL.sales@westcode.com](mailto:WSL.sales@westcode.com)

**IXYS Corporation**  
 3540 Bassett Street  
 Santa Clara CA 95054 USA  
 Tel: +1 (408) 982 0700  
 Fax: +1 (408) 496 0670  
 E-mail: [sales@ixys.com](mailto:sales@ixys.com)

[www.westcode.com](http://www.westcode.com)

[www.ixys.com](http://www.ixys.com)

**Westcode Semiconductors Inc**  
 3270 Cherry Avenue  
 Long Beach CA 90807 USA  
 Tel: +1 (562) 595 6971  
 Fax: +1 (562) 595 8182  
 E-mail: [WSI.sales@westcode.com](mailto:WSI.sales@westcode.com)

The information contained herein is confidential and is protected by Copyright. The information may not be used or disclosed except with the written permission of and in the manner permitted by the proprietors Westcode Semiconductors Ltd.

© Westcode Semiconductors Ltd.

In the interest of product improvement, Westcode reserves the right to change specifications at any time without prior notice.

# WESTCODE

An IXYS Company

Date:- 17 Mar, 2005

Data Sheet Issue:- 1

## Ultra Rapid Semiconductor Protection Fuse French Ferrule Type

French Ferrule Fuses  
Voltage Rating 690V  
Current Ratings from 20A to 100A  
Size 22x58



















### Key Features:

- ❖ Extremely high interrupting rating fuses protection of power semiconductors as per IEC Standard 60269.1 and 4.
- ❖ 660V to 690V voltage rating complying with IEC 33
- ❖ Non Magnetic construction
- ❖ gR Characteristics with current ratings from 1A to 32A in accordance with VDE 636-23
  - Clearing all overloads
  - Improved safety and protection
  - Enabling selective co-ordination among all distribution circuit fuses
- ❖ All models available with or without trip-indicator
- ❖ gRC fuses are 700VAC-DC UL recognised



**Main Characteristics:**

Size	Voltage $U_N$ (V)	Ref:		Current rating $I_N$ (A)	Pre-arcing $I^2t @ 1 \text{ ms}$ $I^2t_p(A^2s)$	Total Clearing $I^2t @ U_N$ ( $A^2s$ )	Power Losses $0.8I_N$	$I_N$	Tested Interrupting rating tested
<b>22x58 without trip indicator</b>	690V	F070C020N		20	17	125	4	6.5	100kA @ 690V
		F070C025N		25	39	280	4.5	7.5	
		F070C032N		32	72	490	5	9	
		F070C040N		40	118	785	5.5	10	
		F070C050N		50	242	1390	7	11.5	
		F070C063N		63	430	2460	8	13.5	
		F070C080N		80	970	5565	9	15.5	
		F070C100N		100	2080	11950	10	17	

Size	Voltage $U_N$ (V)	Ref:		Current rating $I_N$ (A)	Pre-arcing $I^2t @ 1 \text{ ms}$ $I^2t_p(A^2s)$	Total Clearing $I^2t @ U_N$ ( $A^2s$ )	Power Losses $0.8I_N$	$I_N$	Tested Interrupting rating
<b>22x58 with Trip indicator</b>	690V	F070C020S		20	17	125	4	6.5	100kA @ 690V
		F070C025S		25	39	280	4.5	7.5	
		F070C032S		32	72	490	5	9	
		F070C040S		40	118	785	5.5	10	
		F070C050S		50	242	1390	7	11.5	
		F070C063S		63	430	2460	8	13.5	
		F070C080S		80	970	5565	9	15.5	
		F070C100S		100	2080	11950	10	17	

Notes: Minimum operating voltage for integrated trip indicator = 20V

**Electrical Characteristics:**

**Times vs current characteristics**

The following curve indicate, for each rated current, pre-arcing time as a function of RMS value of pre-arcing current I.

Tolerance for mean pre-arcing current:

±10% = ratings from 1, 2, 4A

± 8% = ratings from 6 to 63A

Fuses with gR characteristics can eliminate all overloads.

They do not show a minimum breaking capacity but limit currents of non-operation or operation in compliance with standard VDE 636/23.

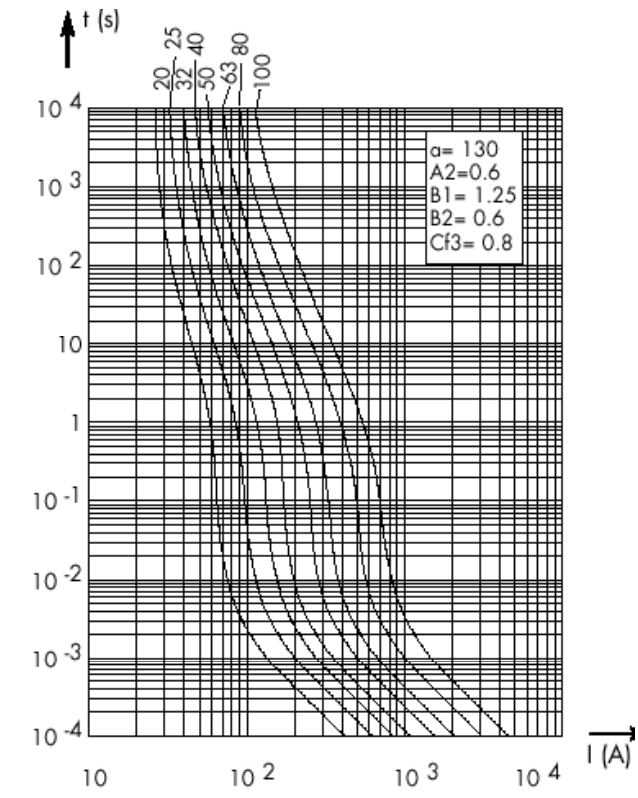

**Total clearing I<sup>2</sup>T:**

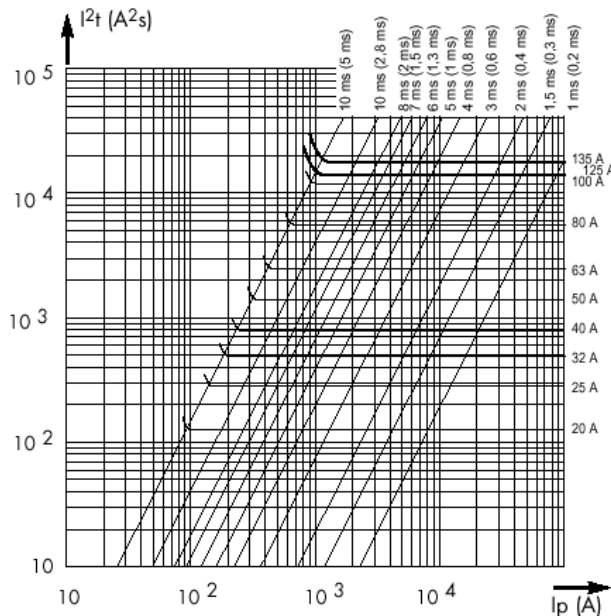

Horizontal curve shows maximum values of total clearing I<sup>2</sup>t (I<sup>2</sup>t<sub>t</sub>) for each rated current as a function of prospective current Ip @ 690V cosφ = 0.15 (for 125-135A @ 600V cosφ = 0.15). Oblique lines indicate total clearing duration Tt, with associated pre-arcing duration in brackets.

**Cut off Characteristics:**

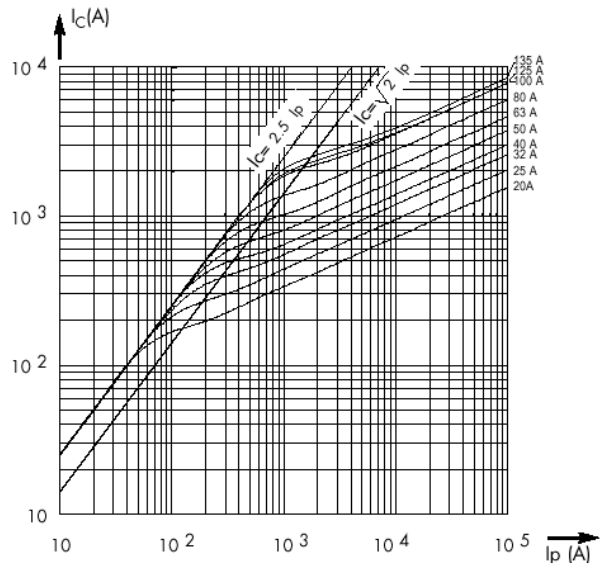

The curve above shows, for each rating, value of peak let-through current Ic as a function of available fault current Ip.

**Corrective Factor**

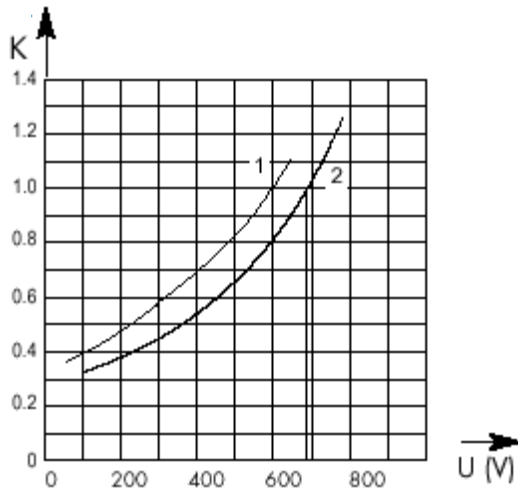

Mean curves showing variation of total clearing time ( $I^2t_t$ ) and total clearing duration  $Tt$  as a function of operating voltage  $U$ .

125A and 135A rating (2) 20-100A rating

**Peak arc voltage**

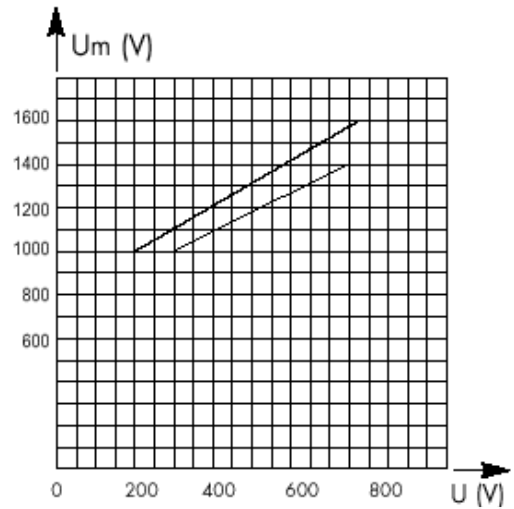

Curves showing peak value  $U_m$  of arc voltage which appears across fuse-link as a function of operating voltage  $U$  @  $\cos\phi = 0.15$

**Outline Drawing & Ordering Information**

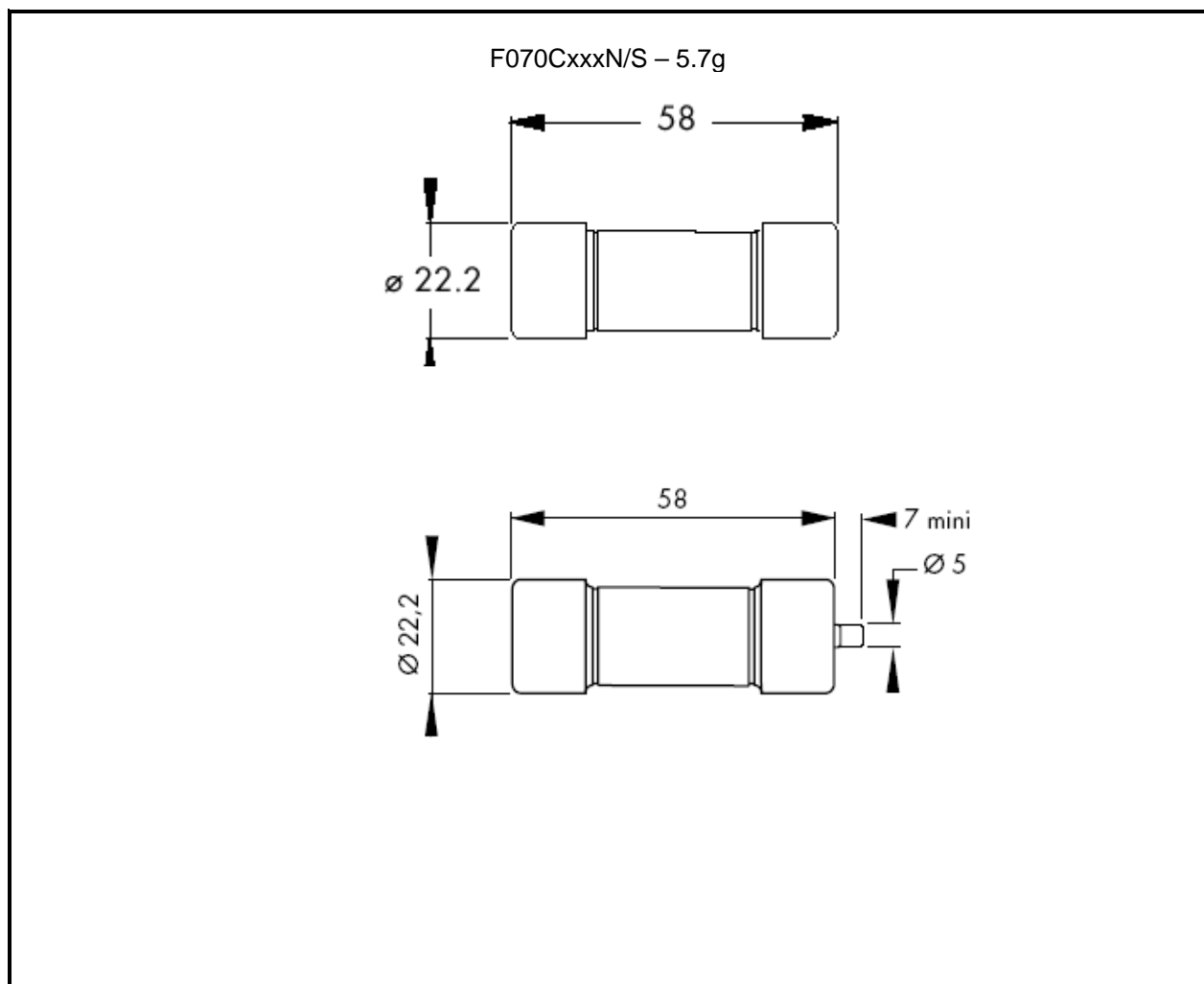

ORDERING INFORMATION				
(Please quote code as below)				
Type	Voltage Rating (V)	Size	Current Rating (A)	With (S) or without (N) Indicator
F	690	C	020 - 100	N or S

Order code: e.g. F070C050S = French Ferrule Fuse, 690V, 50Amps with trip indicator

**IXYS Semiconductor GmbH**  
 Edisonstraße 15  
 D-68623 Lampertheim  
 Tel: +49 6206 503-0  
 Fax: +49 6206 503-627  
 E-mail: [marcom@ixys.de](mailto:marcom@ixys.de)

**WESTCODE**  
 An IXYS Company

**Westcode Semiconductors Ltd**  
 Langley Park Way Langley Park  
 Chippenham Wiltshire SN15 1GE  
 Tel: +44 (0)1249 444524  
 Fax: +44 (0)1249 659448  
 E-mail: [WSL.sales@westcode.com](mailto:WSL.sales@westcode.com)

**IXYS Corporation**  
 3540 Bassett Street  
 Santa Clara CA 95054 USA  
 Tel: +1 (408) 982 0700  
 Fax: +1 (408) 496 0670  
 E-mail: [sales@ixys.com](mailto:sales@ixys.com)

[www.westcode.com](http://www.westcode.com)

[www.ixys.com](http://www.ixys.com)

**Westcode Semiconductors Inc**  
 3270 Cherry Avenue  
 Long Beach CA 90807 USA  
 Tel: +1 (562) 595 6971  
 Fax: +1 (562) 595 8182  
 E-mail: [WSI.sales@westcode.com](mailto:WSI.sales@westcode.com)

The information contained herein is confidential and is protected by Copyright. The information may not be used or disclosed except with the written permission of and in the manner permitted by the proprietors Westcode Semiconductors Ltd.

© Westcode Semiconductors Ltd.

In the interest of product improvement, Westcode reserves the right to change specifications at any time without prior notice.

# WESTCODE

An IXYS Company

Date:- 18 Mar, 2005

Data Sheet Issue:- 1

## Ultra Rapid Semiconductor Protection Fuse European Square Body Fuses













German Standard DIN 80 Blade Contact  
Voltage Ratings 600V to 690V  
Current Ratings 63A to 1600A  
aR Characteristics  
Sizes 0, 1, 2, 3













### Key Features:

- ❖ Extremely high interrupting rating fuses for the protection of power semiconductors in accordance with IEC Standard 60269.1 and 4.
- ❖ Exceptionally low  $I^2t$ , power losses
- ❖ Highly reliable low voltage trip indicator system which conforms to UL, IEC, DIN and VDE standards
- ❖ Non Magnetic construction
- ❖ Increased technical performance gives higher ratings and a reduction in volume and weight
- ❖ Microswitch system reference : MS 3V 1-5
- ❖ Fuse holder types : SI DIN80 630A or SI DIN80 1250A









**Main Characteristics:**

Size	Voltage	Ref:		Current rating $I_N$ (A)	Pre-arcing $I^2t @ 1 \text{ ms}$ $I^2t_p$ (kA <sup>2</sup> s)	Total Clearing $I^2t @ U_N$ (kA <sup>2</sup> s)	Watt Losses 0.8I <sub>N</sub> I <sub>N</sub>		Tested Interrupting rating
0	690V	069UR0A0063B		63	0.2	1.1	7.5	14	200kA @690V (IEC) 200kA @700V (USA)
		069UR0A0080B		80	0.33	1.8	9.5	19	
		069UR0A0100B		100	0.47	2.5	13.0	26	
		069UR0A0125B		125	0.85	4.5	15.0	30	
		069UR0A0160B		160	1.6	8.5	18.5	37	
		069UR0A0200B		200	3.	15.5	21.5	43	
		069UR0A0250B		250	5.8	30	25	50	
		069UR0A0315B		315	12	62	22.5	55	
		069UR0A0350B		350	15.5	80	30	60	
	069UR0A0400B		400	23	120	32.5	65		
	690V +6%	069UR0A0450B		450	26	150	44	88	
		069UR0A0500B		500	41	240	44	88	
069UR0A0550B			550	52	300	45	90		











Notes: Minimum operating voltage for integrated trip indicator = 20V  
Microswitch Reference : MS 3V 1-5

Size	Voltage	Ref:		Current rating $I_N$ (A)	Pre-arcing $I^2t @ 1 \text{ ms}$ $I^2t_p$ (kA <sup>2</sup> s)	Total Clearing $I^2t @ U_N$ (kA <sup>2</sup> s)	Watt Losses 0.8I <sub>N</sub> I <sub>N</sub>		Tested Interrupting rating
1	690V	069UR1A0160B		160	1.3	7	27.5	35	200kA @690V (IEC) 200kA @700V (USA)
		069UR1A0200B		200	2.6	13.5	22.5	45	
		069UR1A0315B		250	4.7	25	25.5	52	
		069UR1A0315B		315	7.5	40	32.5	65	
		069UR1A0350B		350	10.5	55	33.5	67	
		069UR1A0400B		400	19	100	34	68	
		069UR1A0450B		450	26.5	140	35	70	
		069UR1A0500B		500	37	195	36	72	
		069UR1A0550B		550	52	280	37.5	75	
		069UR1A0630B		630	75	390	42.5	85	
		069UR1A0700B		700	95	490	42.5	95	

Notes: Minimum operating voltage for integrated trip indicator = 20V  
Microswitch Reference : MS 3V 1-5

Size	Voltage	Ref:		Current rating $I_N$ (A)	Pre-arcing $I^2t @ 1 \text{ ms}$ $I^2t_p(\text{kA}^2\text{s})$	Total Clearing $I^2t @ U_N$ (kA <sup>2</sup> s)	Watt Losses 0.8I <sub>N</sub> I <sub>N</sub>		Tested Interrupting rating
2	690V	069UR2A0400B		400	15	80	32.5	75	200kA @690V (IEC)
		069UR2A0450B		450	20	115	40	80	
		069UR2A0500B		500	28	145	45	90	
		069UR2A0550B		550	37	195	47.5	95	
		069UR2A0630B		630	54	280	52.5	105	
		069UR2A0700B		700	76	400	55	110	
		069UR2A0800B		800	115	600	60	120	
	690V	069UR2A0900B		900	170	905	62.5	125	170kA @700V (USA)
	+6%	069UR2A1000B		1000	240	1250	67.5	135	
	600V	060UR2A1100B	-	1100	270	1450	82.5	165	150kA @600V (IEC)

Notes: Minimum operating voltage for integrated trip indicator = 20V  
 Microswitch Reference : MS 3V 1-5

Size	Voltage	Ref:		Current rating $I_N$ (A)	Pre-arcing $I^2t @ 1 \text{ ms}$ $I^2t_p(\text{kA}^2\text{s})$	Total Clearing $I^2t @ U_N$ (kA <sup>2</sup> s)	Watt Losses 0.8I <sub>N</sub> I <sub>N</sub>		Tested Interrupting rating
3	690V	069UR3A0500B		500	19	100	52.5	105	200kA @690V (IEC)
		069UR3A0550B		550	27	140	55	110	
		069UR3A0630B		630	40	210	60	120	
		069UR3A0700B		700	55	300	62.5	125	
		069UR3A0800B		800	95	490	65	130	
		069UR3A0900B		900	135	700	67.5	135	
		069UR3A1000B		1000	170	900	77.5	155	
		069UR3A1100B		1100	240	1260	80	160	
	690V	069UR3A1250B		1250	350	1850	90	180	160kA @700V (USA)
	+6%	069UR3A1400B		1400	480	2500	100	200	
600V	060UR3A1600B	-	1600	555	2900	120	240	200kA @600V (IEC)	

Notes: Minimum operating voltage for integrated trip indicator = 20V  
 Microswitch Reference : MS 3V 1-5

**Electrical Characteristics:**

**Times vs current characteristics**

The following curves indicate the pre-arcing time for each rated current as a function of RMS value of pre-arcing current I:

- Tolerances on this current ± 8%
- Beyond 30 sec or 10 sec, small overloads must be eliminated by another device.

Curve CC' represents the maximum times taken by the associated device to clear small overloads; only its horizontal line is represented.

Its oblique line must be plotted according to sketch in top right corner:

- The intersection of the fuse and CC' curves indicates the minimum breaking current I<sub>pm</sub> of the fuse.

**Times vs current characteristics**

**Size 0**

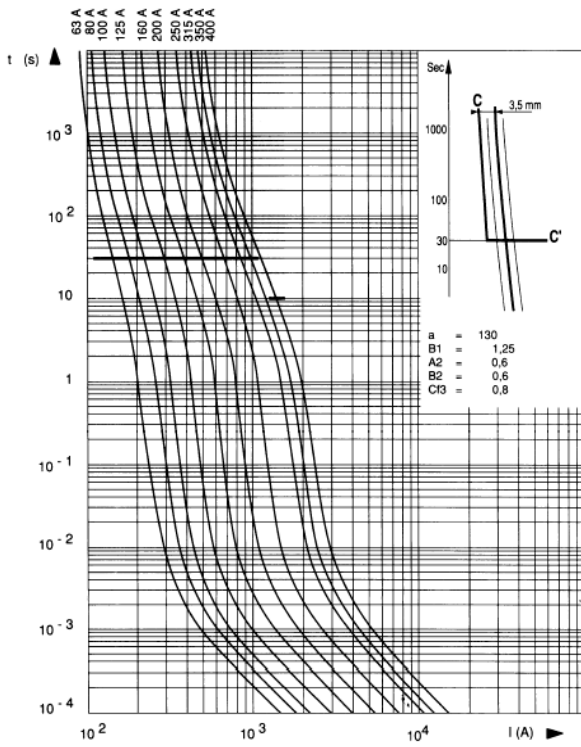

**Size 1**

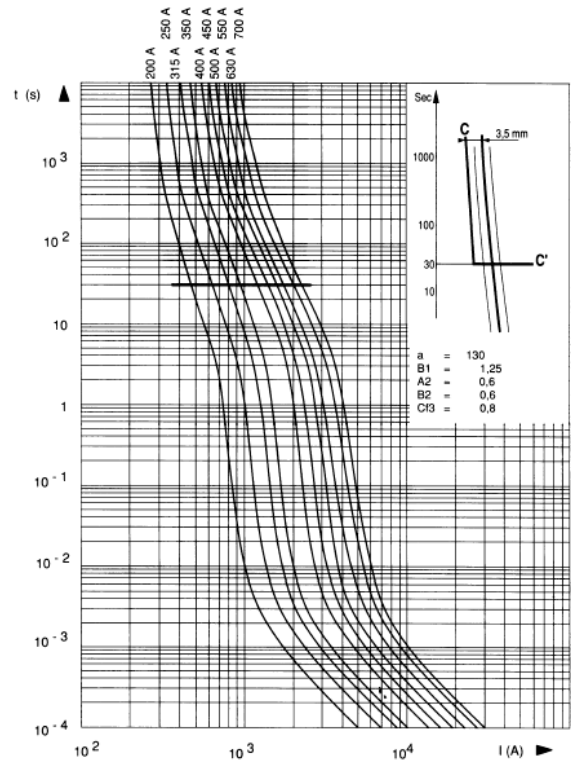

**Size 2**

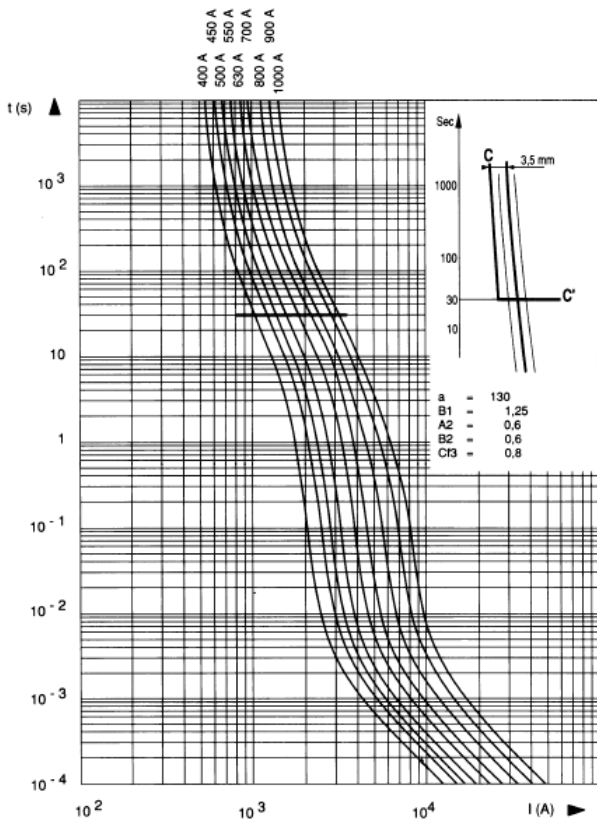

**Size 3**

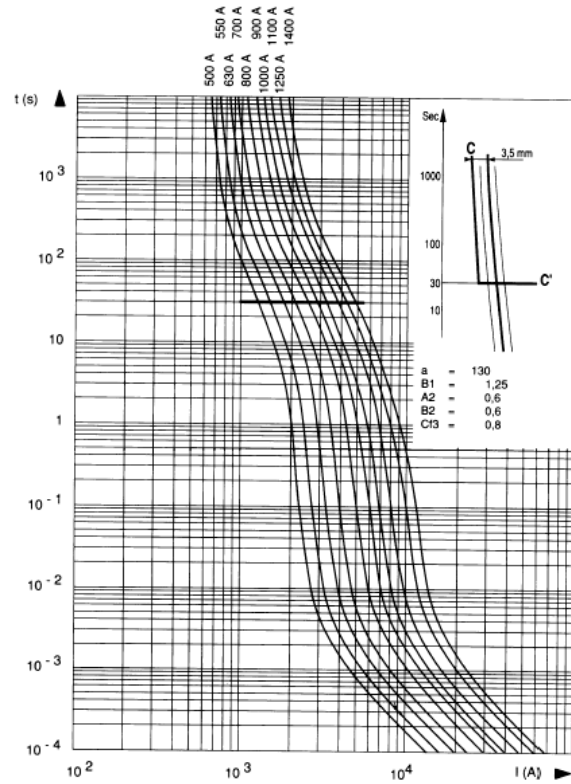



**Total clearing I<sup>2</sup>T:**

The horizontal curves given below indicated the maximum values of total operating I<sup>2</sup>t (I<sup>2</sup>t<sub>t</sub>) as a function of prospective current I<sub>p</sub> @ 660V, cosφ = 0.15. Oblique lines indicate the corresponding total operating time T<sub>t</sub>, with pre-arcing time in brackets.

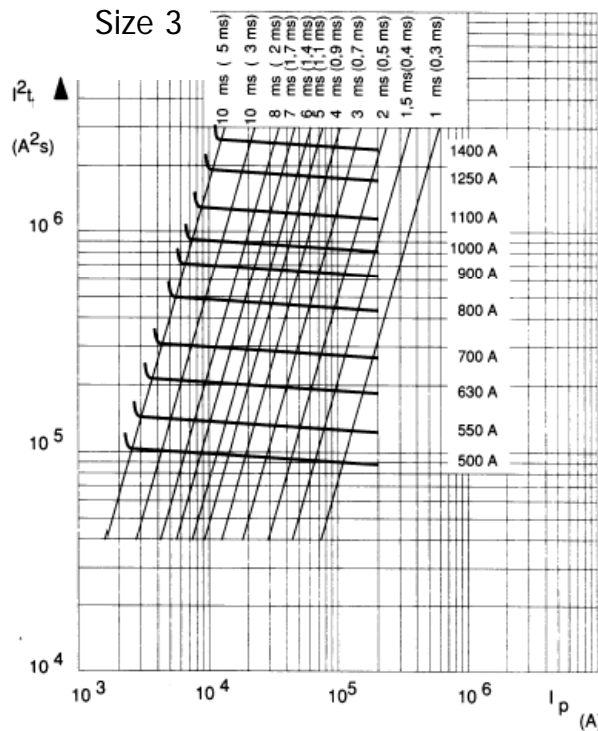
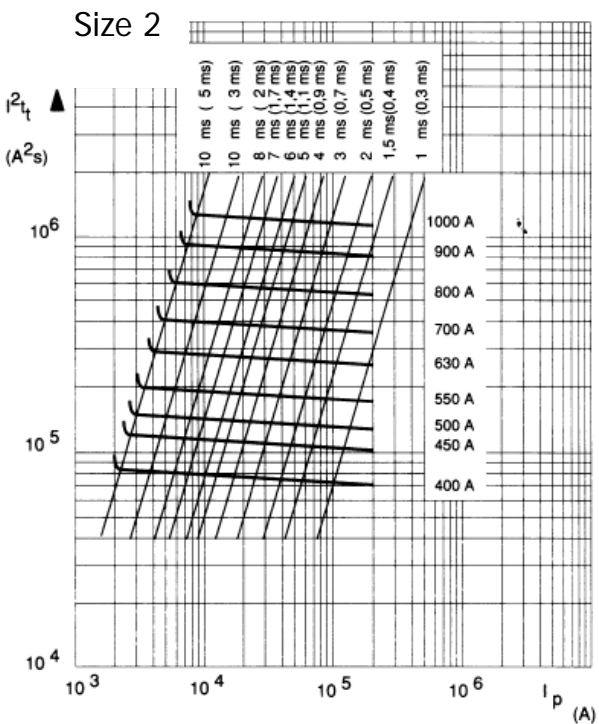
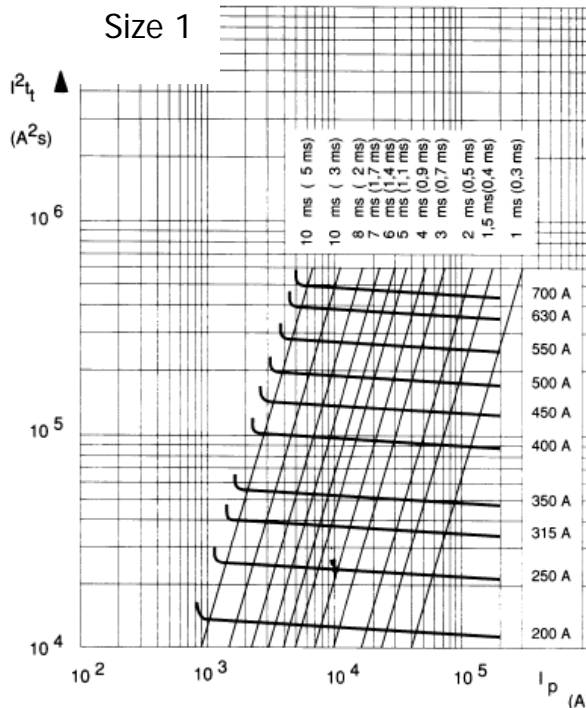
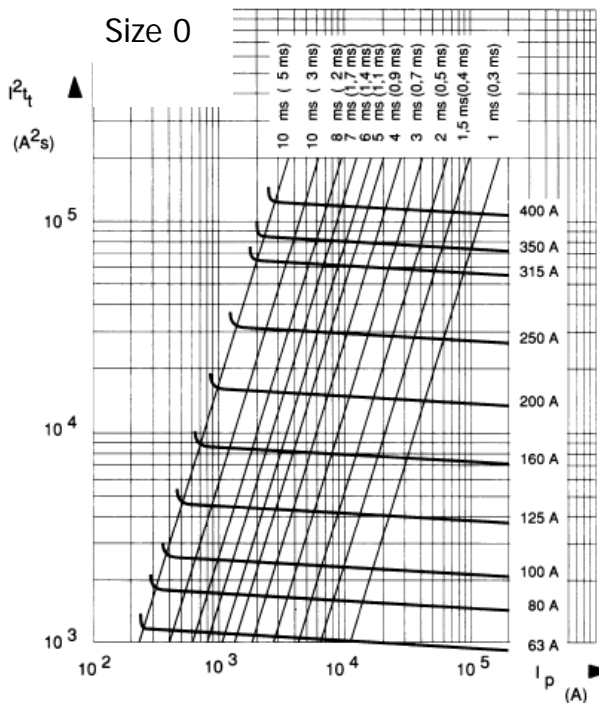

**Cut off Characteristics:**

The curves below indicate, for each rated current, the peak value  $I_c$  that the current may reach as a function of the prospective fault current  $I_p$ .

**Size 0**

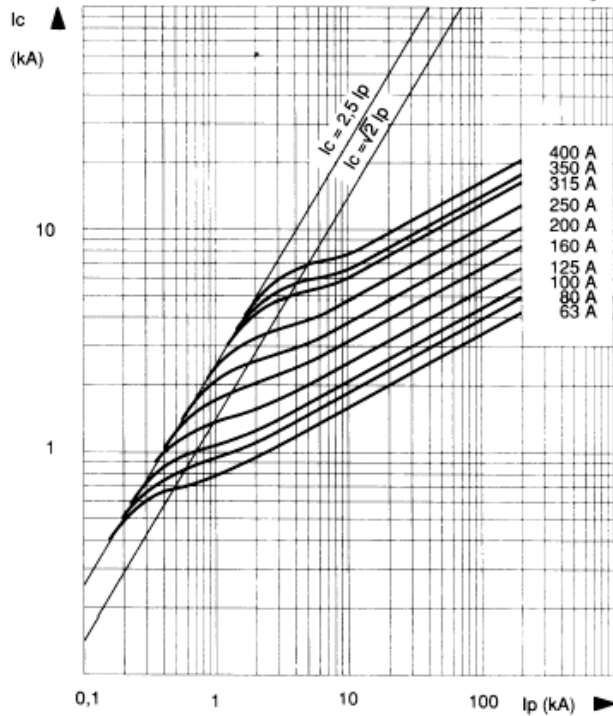

**Size 1**

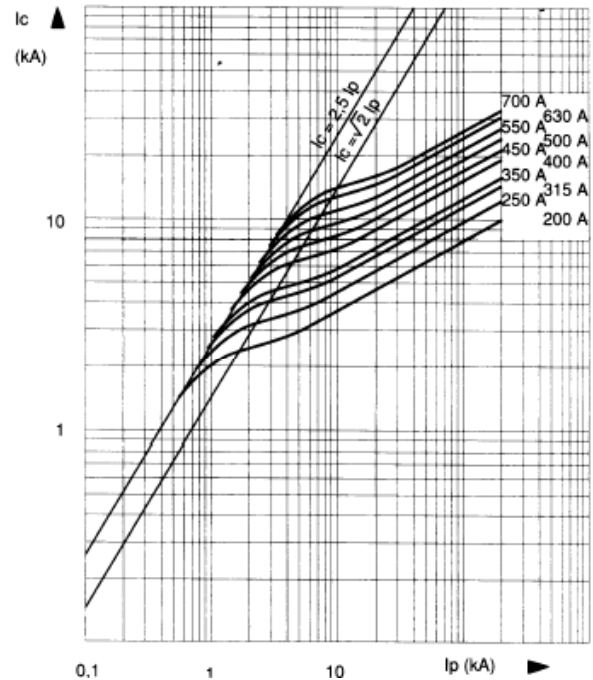

**Size 2**

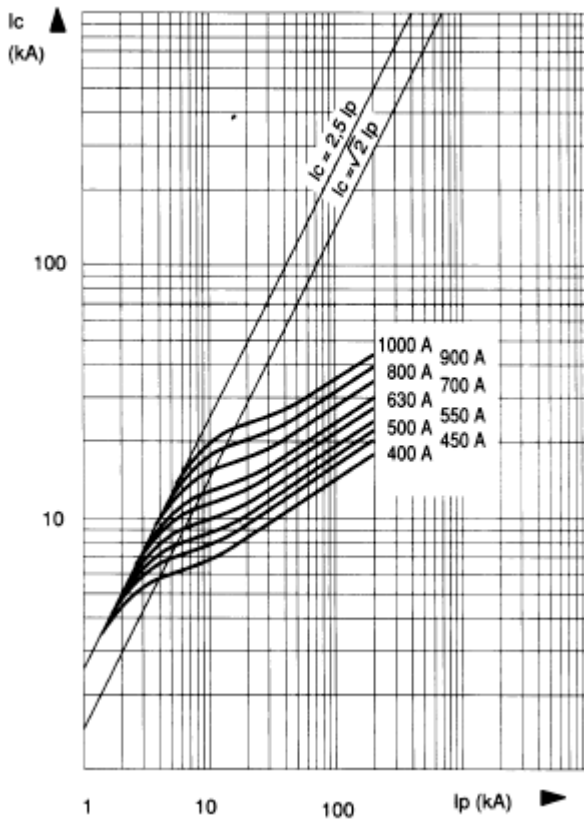

**Size 3**

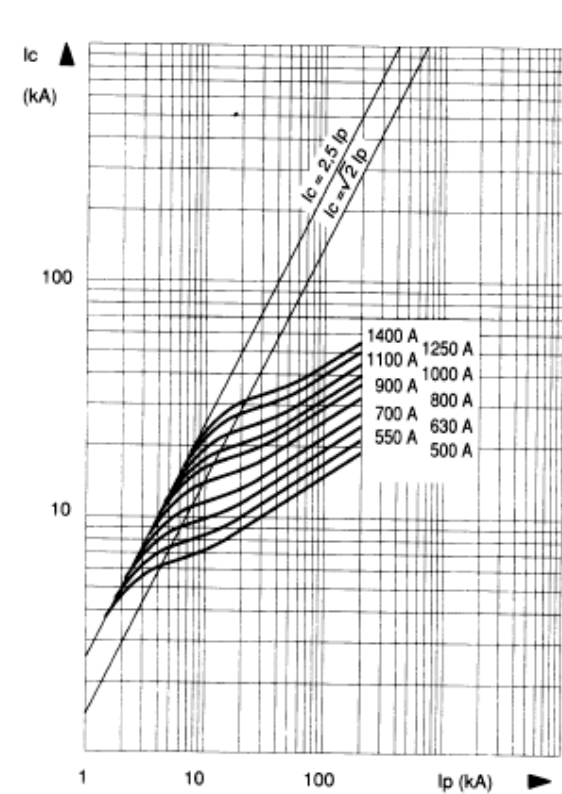

### I<sup>2</sup>t Multiplier Coefficient

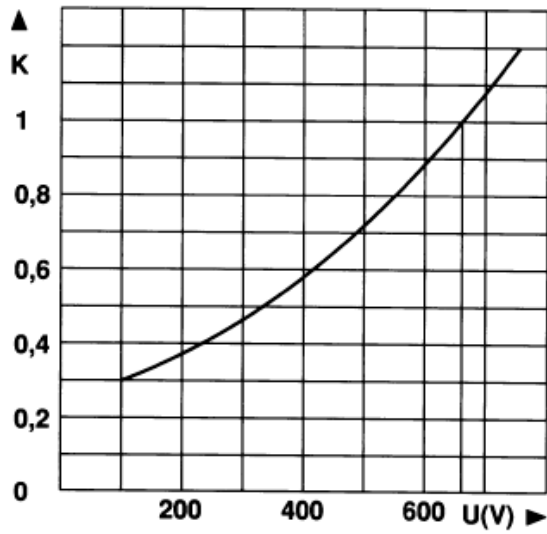

The above Mean curve shows variation of total clearing time ( $I^2t_i$ ) and total operating time  $T_i$  in accordance with working voltage U.

### Peak Arc Voltage

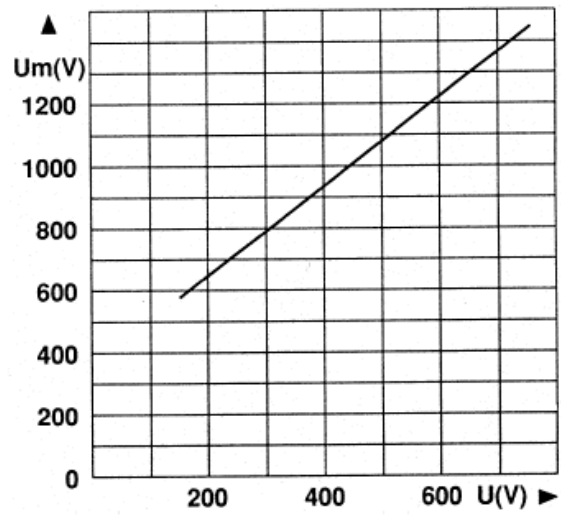

Curve indicating peak arc voltage  $U_m$  which may appear across fuse terminals as a function of working voltage U @  $\cos \varphi = 0.15$ .

### Dissipated Power

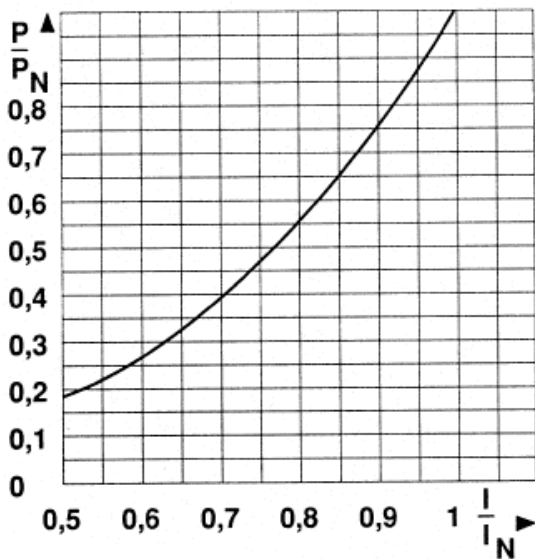

Curve enabling calculation of dissipated power P by a fuse rated  $I_N$ , as a function of the RMS current I, in multiples of  $I_N$  in a steady state.

**Outline Drawing & Ordering Information:**

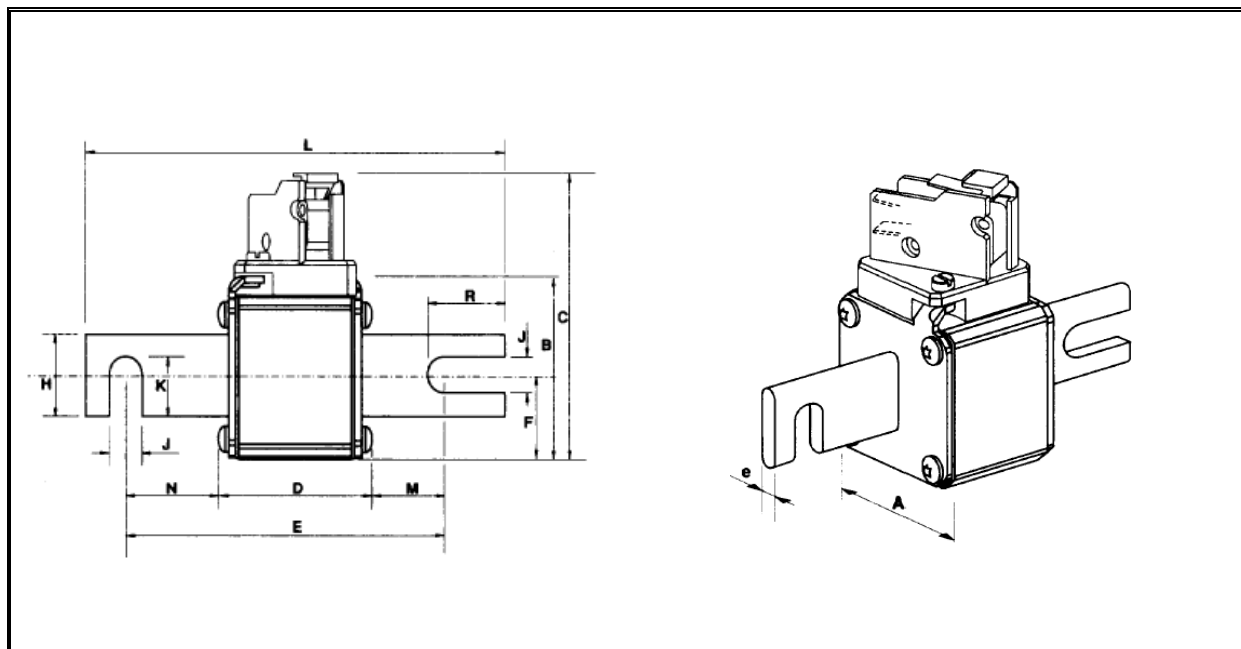

**Dimensions (mm)**

Size	A	B	C	D	E	F	H	J	K	L	M	N	R	e	Weight
0	40	46.5	82	47.5	77	21	25	10.5	17.7	110	11.5	18.5	25.2	6	290g
1	51	56.5	91	47.5	77	25.5	25	10.5	17.7	110	11.5	18.5	25.2	6	430g
2	60	65.5	100	47.5	77	30	32	10.5	21.2	110	11.5	18.5	25.2	6	590g
3	74.5	79.5	114	48.5	77	37.2	40	10.5	25.2	110	11	18	25.2	6	860g

**ORDERING INFORMATION**

(Please quote code as below)

Voltage Rating (V)	Type	Size	Fixing	Current Rating (A)	Indicator
600 – 690	UR	0, 1, 2, 3	A	0063 – 1600	B

Order code: e.g. **069UR1A0350B** = 690V, German Blade Contact, Size 1, DIN80 fixing, 350A, with button indicator

**IXYS Semiconductor GmbH**  
 Edisonstraße 15  
 D-68623 Lampertheim  
 Tel: +49 6206 503-0  
 Fax: +49 6206 503-627  
 E-mail: [marcom@ixys.de](mailto:marcom@ixys.de)



An IXYS Company

**Westcode Semiconductors Ltd**  
 Langley Park Way Langley Park  
 Chippenham Wiltshire SN15 1GE  
 Tel: +44 (0)1249 444524  
 Fax: +44 (0)1249 659448  
 E-mail: [WSL.sales@westcode.com](mailto:WSL.sales@westcode.com)

**IXYS Corporation**  
 3540 Bassett Street  
 Santa Clara CA 95054 USA  
 Tel: +1 (408) 982 0700  
 Fax: +1 (408) 496 0670  
 E-mail: [sales@ixys.com](mailto:sales@ixys.com)

[www.westcode.com](http://www.westcode.com)

[www.ixys.com](http://www.ixys.com)

**Westcode Semiconductors Inc**  
 3270 Cherry Avenue  
 Long Beach CA 90807 USA  
 Tel: +1 (562) 595 6971  
 Fax: +1 (562) 595 8182  
 E-mail: [WSI.sales@westcode.com](mailto:WSI.sales@westcode.com)

The information contained herein is confidential and is protected by Copyright. The information may not be used or disclosed except with the written permission of and in the manner permitted by the proprietors Westcode Semiconductors Ltd.

© Westcode Semiconductors Ltd.

In the interest of product improvement, Westcode reserves the right to change specifications at any time without prior notice.

# WESTCODE

An IXYS Company

Date:- 18 Mar, 2005

Data Sheet Issue:- 1

## Ultra Rapid Semiconductor Protection Fuse European Square Body Fuses













German Standard DIN 110 Blade Contact  
Voltage Ratings 600V to 690V  
Current Ratings 63A to 1600A  
Sizes 0, 1, 2, 3













### Key Features:

- ❖ Extremely high interrupting rating fuses for the protection of power semiconductors in accordance with IEC Standard 60269.1 and 4.
- ❖ Exceptionally low  $I^2t$ , power losses
- ❖ Highly reliable low voltage trip indicator system which conforms to UL, IEC, DIN and VDE standards
- ❖ Non Magnetic construction
- ❖ Increased technical performance gives higher ratings and a reduction in volume and weight
- ❖ Microswitch system reference : MS 3V 1-5
- ❖ Fuse holder types : SI DIN80 630A or SI DIN80 1250A









**Main Characteristics:**

Size	Voltage	Ref:		Current rating $I_N$ (A)	Pre-arcing $I^2t @ 1 \text{ ms}$ $I^2t_p$ (kA <sup>2</sup> s)	Total Clearing $I^2t @ U_N$ (kA <sup>2</sup> s)	Watt Losses 0.8 $I_N$ $I_N$		Tested Interrupting rating
0	690V	069UR0D0063B		63	0.2	1.1	7.5	14	200kA @690V
		069UR0D0080B		80	0.33	1.8	9.5	19	
		069UR0D0100B		100	0.47	2.50	13.0	26	
		069UR0D0125B		125	0.85	4.50	15.0	30	
		069UR0D0160B		160	1.6	8.5	18.5	37	
		069UR0D0200B		200	3.	15.5	21.5	43	
		069UR0D0250B		250	5.8	30	25	50	
		069UR0D0315B		315	12	62	22.5	55	
		069UR0D0350B		350	15.5	80	30	60	
		069UR0D0400B		400	23	120	32.5	65	
	690V +6%	069UR0D0450B		450	26	150	44	88	
		069UR0D0500B		500	41	240	44	88	
		069UR0D0550B	-	550	52	300	45	90	











Notes: Minimum operating voltage for integrated trip indicator = 20V  
Microswitch Reference : MS 3V 1-5

Size	Voltage	Ref:		Current rating $I_N$ (A)	Pre-arcing $I^2t @ 1 \text{ ms}$ $I^2t_p$ (kA <sup>2</sup> s)	Total Clearing $I^2t @ U_N$ (kA <sup>2</sup> s)	Watt Losses 0.8 $I_N$ $I_N$		Tested Interrupting rating
1	690V	069UR1D0160B		160	1.3	7	27.5	35	200kA @690V
		069UR1D0200B		200	2.6	13.5	22.5	45	
		069UR1D0315B		250	4.7	25	25.5	52	
		069UR1D0315B		315	7.5	40	32.5	65	
		069UR1D0350B		350	10.5	55	33.5	67	
		069UR1D0400B		400	19	100	34	68	
		069UR1D0450B		450	26.5	140	35	70	
		069UR1D0500B		500	37	195	36	72	
		069UR1D0550B		550	52	280	37.5	75	
		069UR1D0630B		630	75	390	42.5	85	
		069UR1D0700B		700	95	490	42.5	95	

Notes: Minimum operating voltage for integrated trip indicator = 20V  
Microswitch Reference : MS 3V 1-5

Size	Voltage	Ref:		Current rating $I_N$ (A)	Pre-arcing $I^2t @ 1 \text{ ms}$ $I^2t_p(\text{kA}^2\text{s})$	Total Clearing $I^2t @ U_N (\text{kA}^2\text{s})$	Watt Losses $0.8I_N I_N$		Tested Interrupting rating
2	690V	069UR2D0400B		400	15	80	32.5	75	200kA @660V
		069UR2D0450B		450	20	115	40	80	
		069UR2D0500B		500	28	145	45	90	
		069UR2D0550B		550	37	195	47.5	95	
		069UR2D0630B		630	54	280	52.5	105	
		069UR2D0700B		700	76	400	55	110	
		069UR2D0800B		800	115	600	60	120	
	690V	069UR2D0900B		900	170	900	62.5	125	200kA @600V
	+6%	069UR2D1000B		1000	240	1250	67.5	135	
	600V	060UR2D1100B	-	1100	270	1450	82.5	165	

Notes: Minimum operating voltage for integrated trip indicator = 20V  
Microswitch Reference : MS 3V 1-5

Size	Voltage	Ref:		Current rating $I_N$ (A)	Pre-arcing $I^2t @ 1 \text{ ms}$ $I^2t_p(\text{kA}^2\text{s})$	Total Clearing $I^2t @ U_N (\text{kA}^2\text{s})$	Watt Losses $0.8I_N I_N$		Tested Interrupting rating
3	690V	069UR3D0500B		500	19	100	52.5	105	200kA @660V
		069UR3D0550B		550	27	140	55	110	
		069UR3D0630B		630	40	210	60	120	
		069UR3D0700B		700	55	300	62.5	125	
		069UR3D0800B		800	95	490	65	130	
		069UR3D0900B		900	135	700	67.5	135	
		069UR3D1000B		1000	170	900	77.5	155	
		069UR3D1100B		1100	240	1260	80	160	
	690V	069UR3D1250B		1250	350	1850	90	180	170kA @700V
	+6%	069UR3D1400B		1400	480	2500	100	200	
600V	060UR3D1600B	-	1600	555	3300	120	240		

Notes: Minimum operating voltage for integrated trip indicator = 20V  
Microswitch Reference : MS 3V 1-5

**Electrical Characteristics:**

**Times vs current characteristics**

The following curves indicate the pre-arcing time for each rated current as a function of RMS value of pre-arcing current I:

- Tolerances on this current  $\pm 8\%$
- Beyond 30 sec or 10 sec, small overloads must be eliminated by another device.
- 

Curve CC' represents the maximum times taken by the associated device to clear small overloads; only its horizontal line is represented.

Its oblique line must be plotted according to sketch in top right corner:

- The intersection of the fuse and CC' curves indicates the minimum breaking current  $I_{pm}$  of the fuse.

**Times vs current characteristics**

**Size 0**

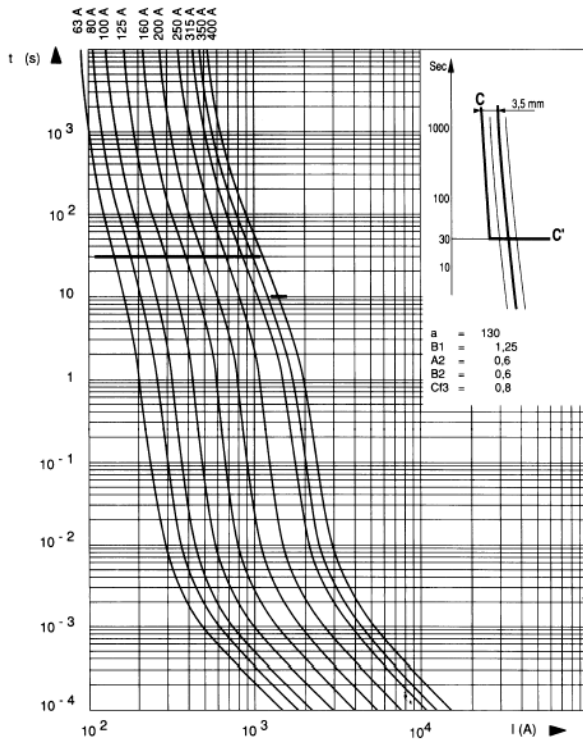

**Size 1**

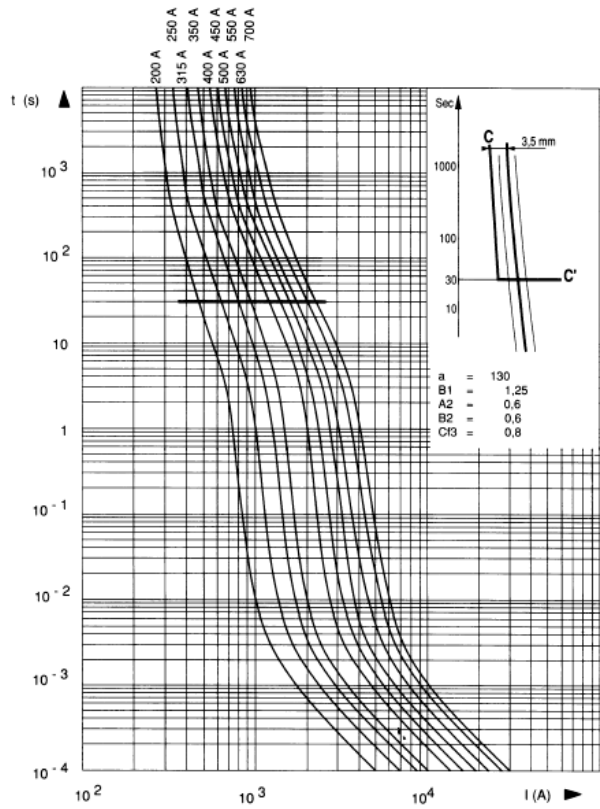

**Size 2**

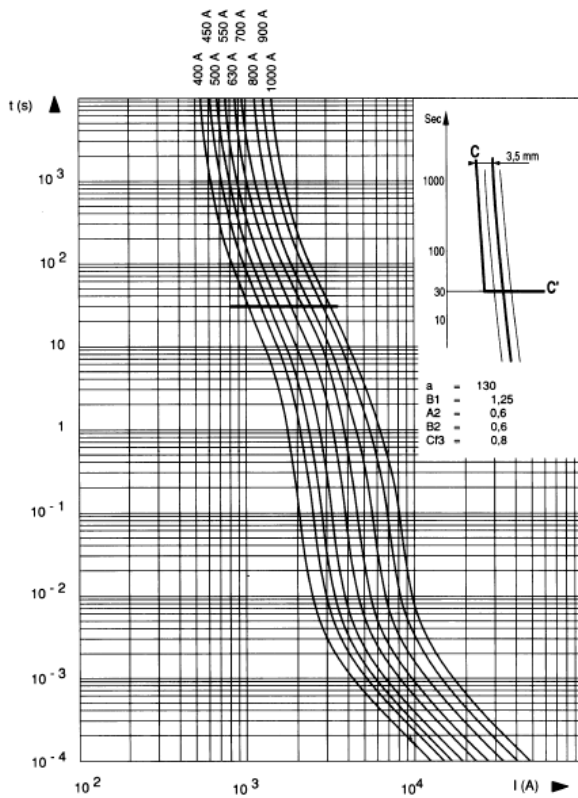

**Size 3**

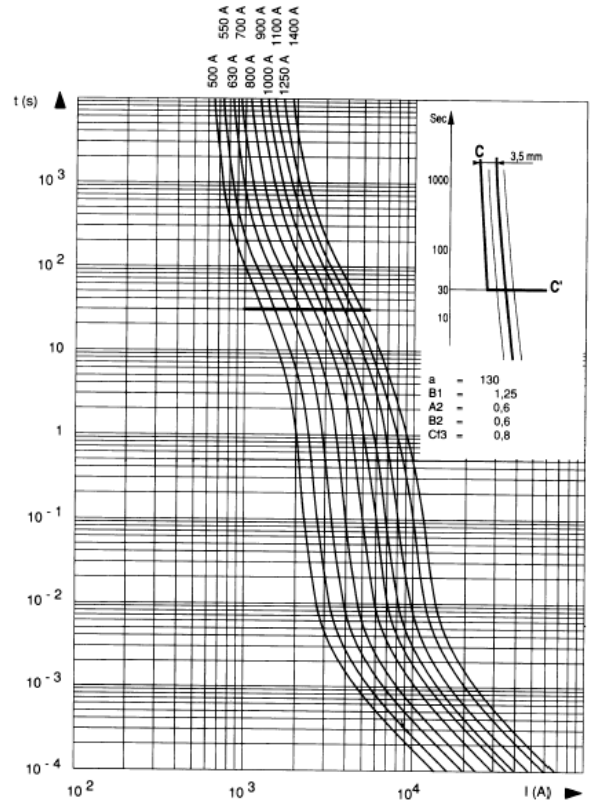



**Total clearing I<sup>2</sup>T:**

The horizontal curves given below indicated the maximum values of total operating I<sup>2</sup>t (I<sup>2</sup>t<sub>t</sub>) as a function of prospective current I<sub>p</sub> @ 660V, cosφ = 0.15. Oblique lines indicate the corresponding total operating time T<sub>t</sub>, with pre-arcing time in brackets.

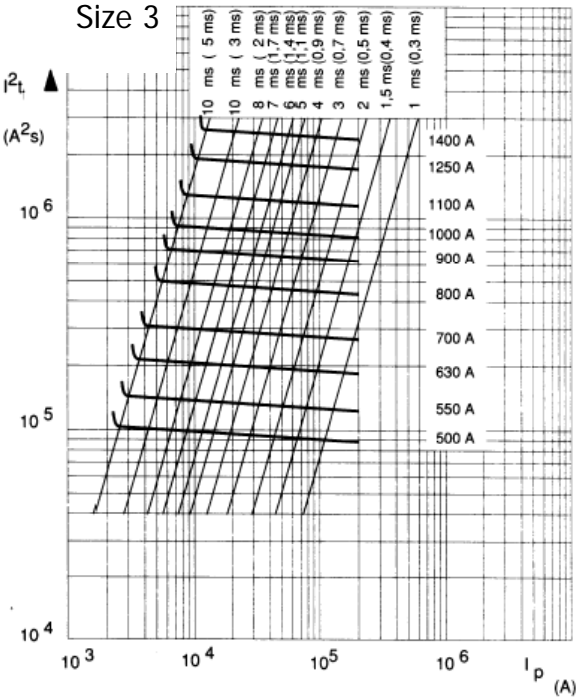
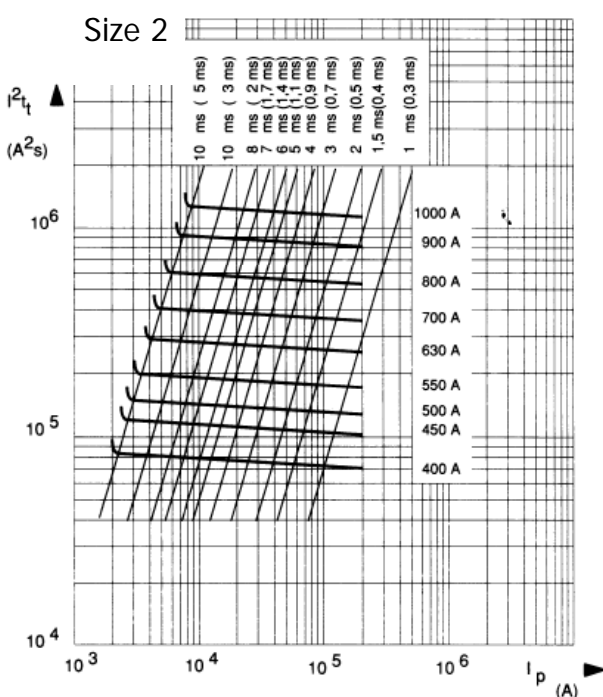
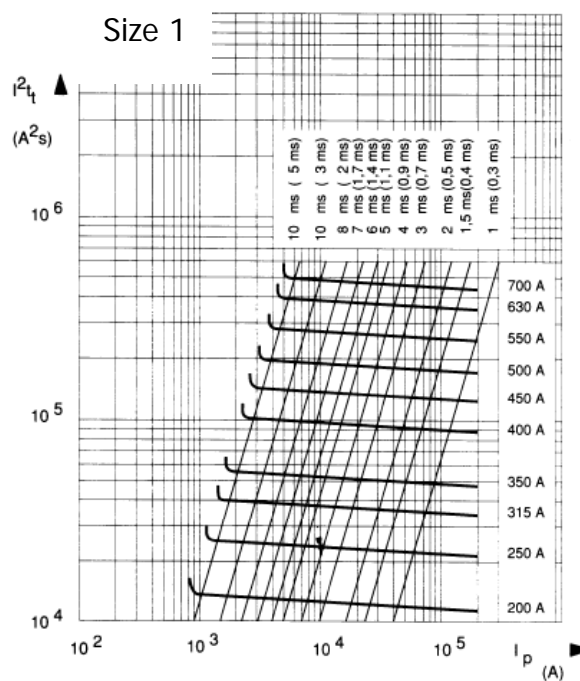
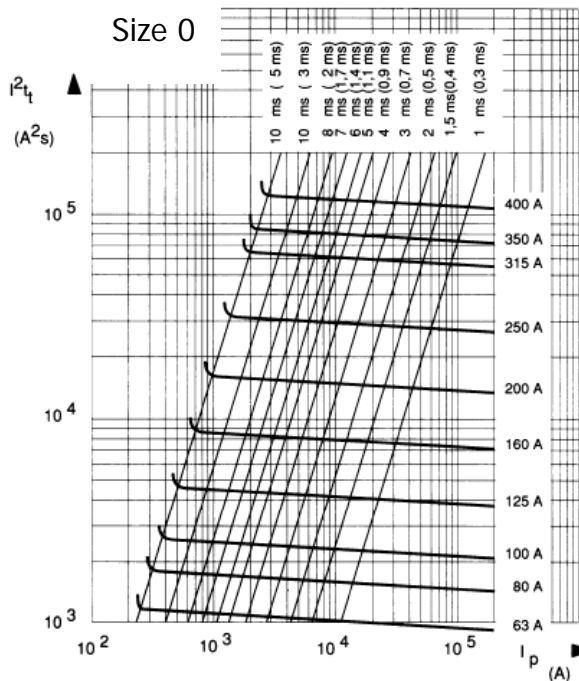

**Cut off Characteristics:**

The curves below indicate, for each rated current, the peak value  $I_c$  that the current may reach as a function of the prospective fault current  $I_p$ .

**Size 0**

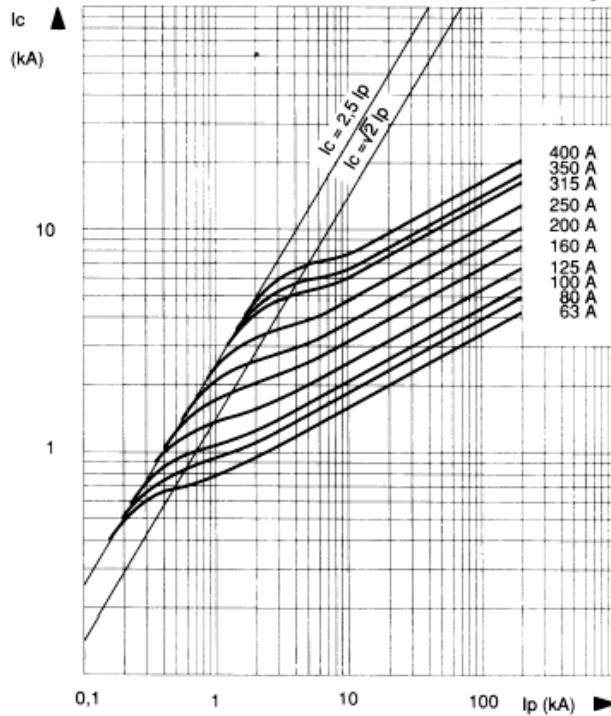

**Size 1**

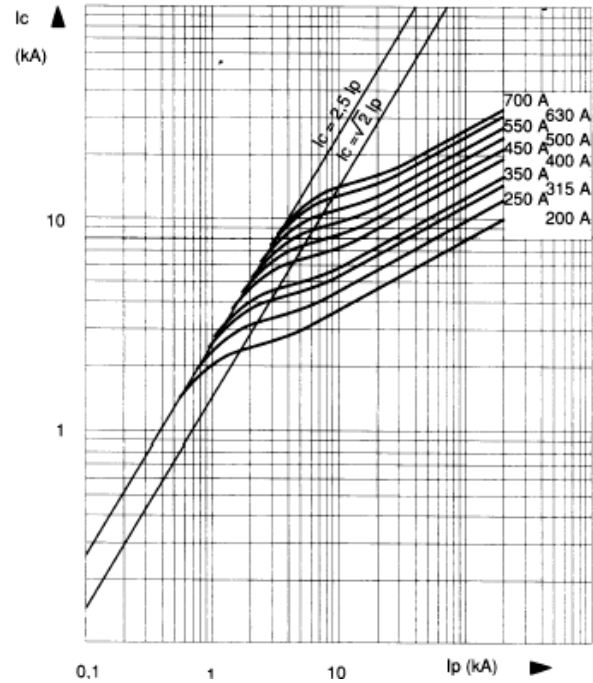

**Size 2**

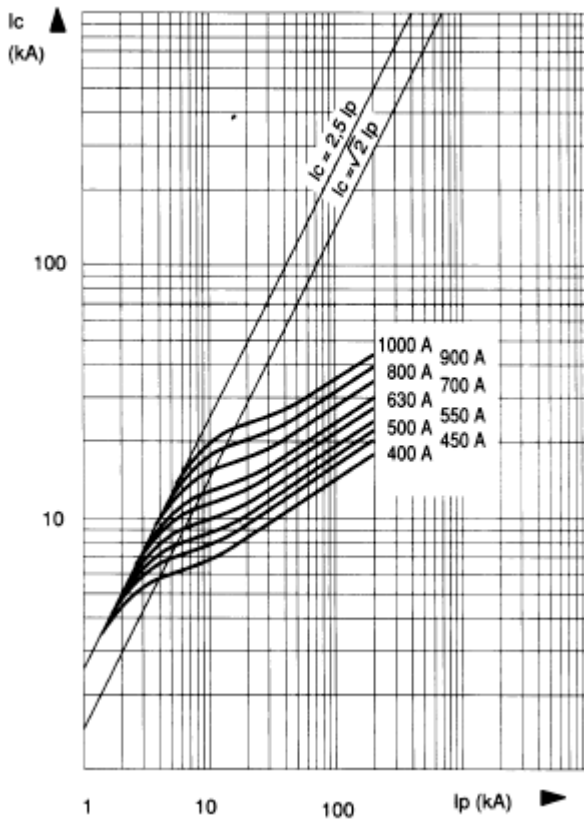

**Size 3**

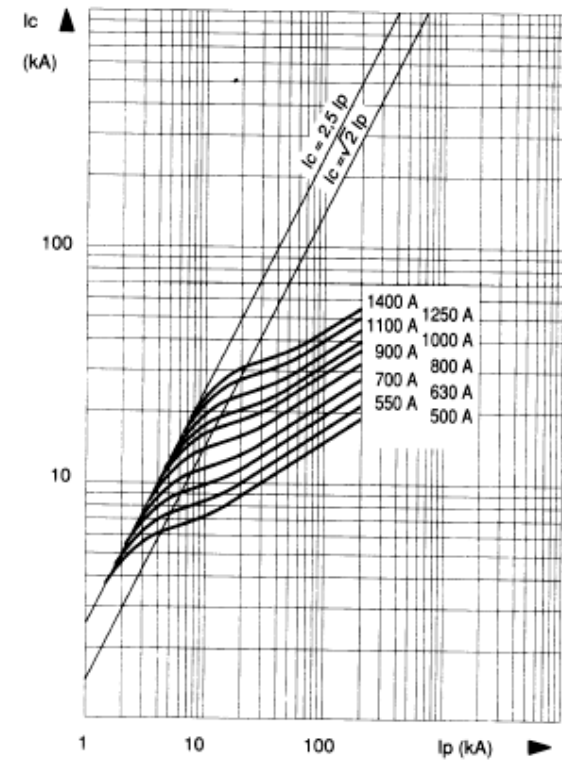

**I<sup>2</sup>t Multiplier Coefficient**

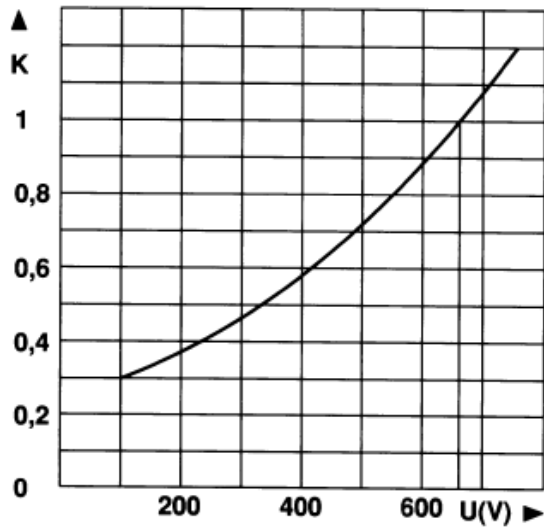

The above Mean curve shows variation of total clearing time ( $I^2t_t$ ) and total operating time  $T_t$  in accordance with working voltage  $U$ .

**Peak Arc Voltage**

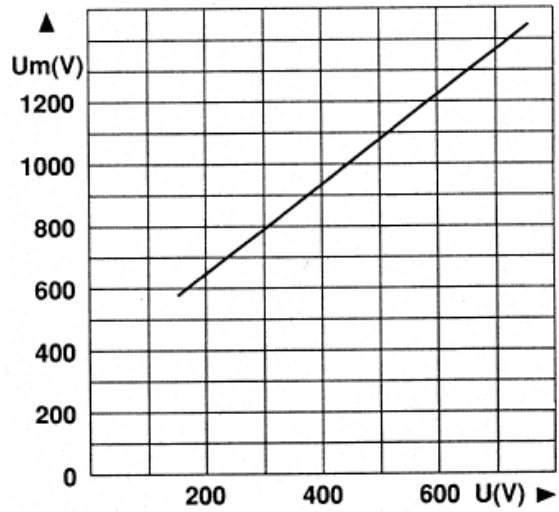

Curve indicating peak arc voltage  $U_m$  which may appear across fuse terminals as a function of working voltage  $U$  @  $\cos \varphi = 0.15$ .

**Dissipated Power**

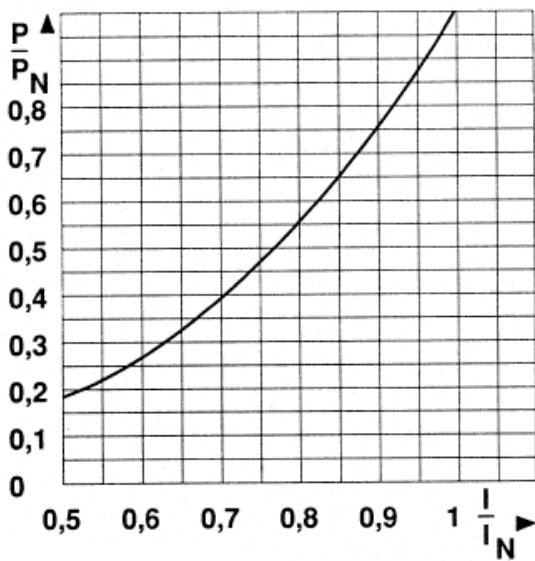

Curve enabling calculation of dissipated power  $P$  by a fuse rated  $I_N$ , as a function of the RMS current  $I$ , in multiples of  $I_N$  in a steady state.

**Outline Drawing & Ordering Information:**

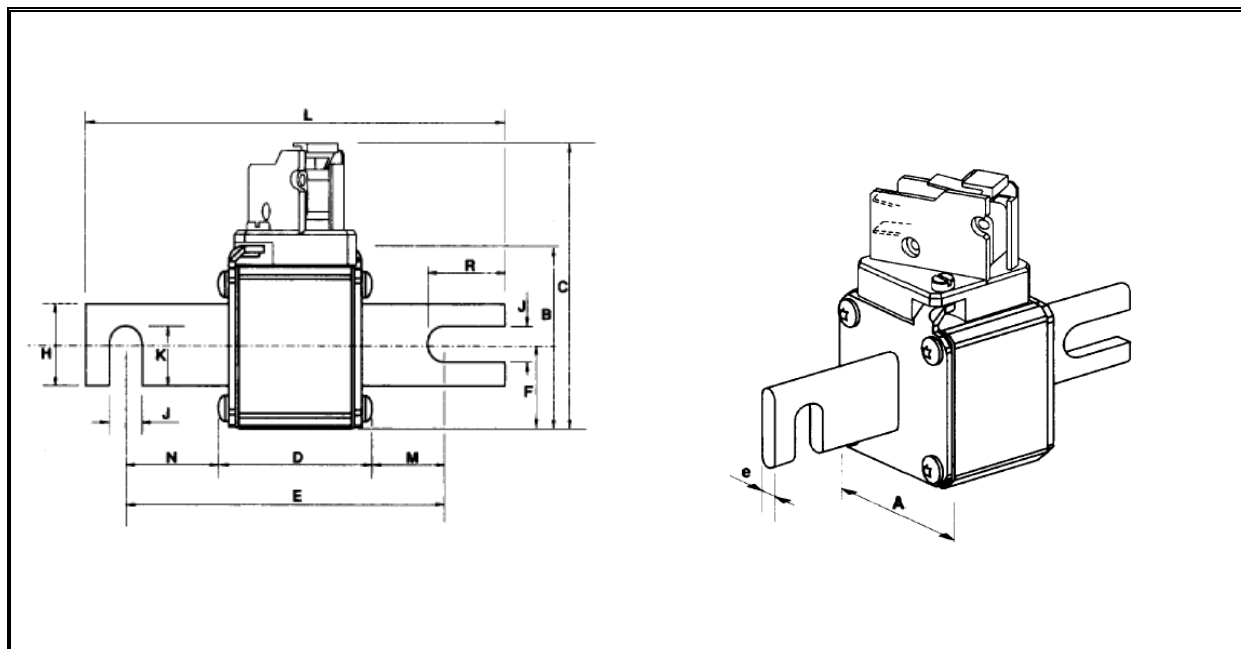

**Dimensions (mm)**

Size	A	B	C	D	E	F	H	J	K	L	M	N	R	e	Weight
0	40	46.5	82	47.5	101.6	21	25	10.5	17.7	134.6	23.8	30.8	25.2	6	290g
1	51	56.5	91	47.5	101.6	25.5	25	10.5	17.7	134.6	23.8	30.8	25.2	6	430g
2	60	65.5	100	47.5	101.6	30	32	10.5	21.2	134.6	23.8	30.8	25.2	6	590g
3	74.5	79.5	114	48.5	101.6	37.2	40	10.5	25.2	134.6	23.3	30.3	25.2	6	860g

**ORDERING INFORMATION**

(Please quote code as below)

Voltage Rating (V)	Type	Size	Fixing	Current Rating (A)	Indicator
600 – 690	UR	0, 1, 2, 3	D	0063 – 1600	B

Order code: e.g. **069UR1A0350B** = 690V, German Blade Contact, Size 1, DIN110, 350A, with button indicator

**IXYS Semiconductor GmbH**  
 Edisonstraße 15  
 D-68623 Lampertheim  
 Tel: +49 6206 503-0  
 Fax: +49 6206 503-627  
 E-mail: [marcom@ixys.de](mailto:marcom@ixys.de)



An IXYS Company

**Westcode Semiconductors Ltd**  
 Langley Park Way Langley Park  
 Chippenham Wiltshire SN15 1GE  
 Tel: +44 (0)1249 444524  
 Fax: +44 (0)1249 659448  
 E-mail: [WSL.sales@westcode.com](mailto:WSL.sales@westcode.com)

**IXYS Corporation**  
 3540 Bassett Street  
 Santa Clara CA 95054 USA  
 Tel: +1 (408) 982 0700  
 Fax: +1 (408) 496 0670  
 E-mail: [sales@ixys.com](mailto:sales@ixys.com)

[www.westcode.com](http://www.westcode.com)  
[www.ixys.com](http://www.ixys.com)

**Westcode Semiconductors Inc**  
 3270 Cherry Avenue  
 Long Beach CA 90807 USA  
 Tel: +1 (562) 595 6971  
 Fax: +1 (562) 595 8182  
 E-mail: [WSI.sales@westcode.com](mailto:WSI.sales@westcode.com)

The information contained herein is confidential and is protected by Copyright. The information may not be used or disclosed except with the written permission of and in the manner permitted by the proprietors Westcode Semiconductors Ltd.

© Westcode Semiconductors Ltd.

In the interest of product improvement, Westcode reserves the right to change specifications at any time without prior notice.

## Ultra Rapid Semiconductor Protection Fuse European Square Body Type

German Standard DIN110  
Voltage Rating 900V to 1250V  
Current Rating 63A to 1800A  
Sizes 0, 1, 2, 3



### Key Features:

- ❖ Extremely high interrupting rating fuses for the protection of power semiconductors in accordance with IEC standard 60269.1 and 4.
- ❖ UL Recognition for many devices, CSA investigated, IEC, DIN and VDE standards
- ❖ Increased technical performance giving higher ratings and a reduction in volume and weight.
- ❖ Exceptionally low  $I^2t$ , power losses
- ❖ Non Magnetic construction
- ❖ Highly reliable low voltage indicator system
- ❖ Microswitch reference MS 7V 1-5

**Main Characteristics:**

Size	Voltage U <sub>N</sub> (V)	Ref:		Current rating I <sub>N</sub> (A)	Pre-arcing I <sup>2</sup> t @ 1 ms I <sup>2</sup> t <sub>p</sub> (kA <sup>2</sup> s)	Total Clearing I <sup>2</sup> t @ U <sub>N</sub> (kA <sup>2</sup> s)	Watt Losses 0.8I <sub>N</sub> I <sub>N</sub>		Tested Interrupting rating
0	1250V	125UR0D0063B		63	0.21	1.2	13	26	100kA @ 1250V
		125UR0D0080B		80	0.47	2.7	13.5	27	
		125UR0D0100B		100	0.83	4.8	15	30	
		125UR0D0125B		125	1.3	7.5	19	38	
		125UR0D0160B		160	2.55	15	22.5	45	
		125UR0D0200B		200	4.7	27	28	56	
		125UR0D0250B		250	9.6	55	30.5	61	
	1200V	120UR0D0280B		280	14	82	32	64	100kA @ 1200V
		120UR0D0315B		315	20	115	36	72	
	1100V	110UR0D0350B		350	28	180	37.5	75	150kA @ 1100V

Notes: Minimum operating voltage for integrated trip indicator = 20V  
 Micro switch reference : MS 7V 1-5

Size	Voltage U <sub>N</sub> (V)	Ref:		Current rating I <sub>N</sub> (A)	Pre-arcing I <sup>2</sup> t @ 1 ms I <sup>2</sup> t <sub>p</sub> (kA <sup>2</sup> s)	Total Clearing I <sup>2</sup> t @ U <sub>N</sub> (kA <sup>2</sup> s)	Watt Losses 0.8I <sub>N</sub> I <sub>N</sub>		Tested Interrupting rating
1	1250V	125UR1D0160B		160	2.6	15	23	46	100kA @ 1250V
		125UR1D0200B		200	4.7	27	27	54	
		125UR1D0250B		250	8.9	51	30.5	61	
		125UR1D0280B		280	12	68	35	70	
		125UR1D0315B		315	16	92	38	76	
		125UR1D0350B		350	22	127	40	80	
		125UR1D0400B		400	38	220	40	80	
		125UR1D0450B		450	47	270	47.5	95	
	1100V	110UR1D0500B		500	68	390	50	100	150kA @ 1100V
		110UR1D0550B		550	84	485	56	112	
		100UR1D0630B		630	125	725	60	120	

Notes: Minimum operating voltage for integrated trip indicator = 20V  
 Micro switch reference : MS 7V 1-5

Size	Voltage U <sub>N</sub> (V)	Ref:		Current rating I <sub>N</sub> (A)	Pre-arcing I <sup>2</sup> t @ 1 ms I <sup>2</sup> t <sub>p</sub> (kA <sup>2</sup> s)	Total Clearing I <sup>2</sup> t @ U <sub>N</sub> (kA <sup>2</sup> s)	Watt Losses 0.8I <sub>N</sub> I <sub>N</sub>		Tested Interrupting rating
2	1250V	125UR2D0280B		280	10	60	36	72	100kA @ 1250V
		125UR2D0315B		315	15	87	38	76	
		125UR2D0350B		350	21	120	38.5	77	
		125UR2D0400B		400	32	190	40	80	
		125UR2D0450B		450	44	255	44.5	89	
		125UR2D0500B		500	57	330	49	98	
	125UR2D0550B		550	68	390	60	120		
	1100V	110UR2D0630B		630	105	610	62.5	125	150kA @ 1100V
	1000V	100UR2D0700B		700	145	815	70	140	150kA @ 1000V
100UR2D0800B			800	215	1240	73	146		

Notes: Minimum operating voltage for integrated trip indicator = 20V  
 Microswitch reference : MS 7V 1-5

Size	Voltage U <sub>N</sub> (V)	Ref:		Current rating I <sub>N</sub> (A)	Pre-arcing I <sup>2</sup> t @ 1 ms I <sup>2</sup> t <sub>p</sub> (kA <sup>2</sup> s)	Total Clearing I <sup>2</sup> t @ U <sub>N</sub> (kA <sup>2</sup> s)	Watt Losses 0.8I <sub>N</sub> I <sub>N</sub>		Tested Interrupting rating
3	1250V	125UR3D0315B		315	12	68	42	84	100kA @ 1250V
		125UR3D0350B		350	17	100	43	86	
		125UR3D0400B		400	25	145	46.5	93	
		125UR3D0450B		450	35	205	50	100	
		125UR3D0500B		500	44	255	56	112	
		125UR3D0550B		550	57	330	60	120	
	1200V	120UR3D0700B		700	110	640	73	146	100kA @ 1200V
	1100V	110UR3D0800B		800	190	1090	74	148	150kA @ 1100V
	1000V	100UR3D0900B		900	250	1440	85	170	150kA @ 1000V
	900V	090UR3D1000B		1000	370	1920	87	174	150kA @ 900V
		090UR3D1100B		1100	445	2280	104	208	

Notes: Minimum operating voltage for integrated trip indicator = 20V  
 Microswitch reference : MS 7V 1-5

**Electrical Characteristics:**

**Times vs current characteristics**

The curves shown on page 4 indicate the pre-arcing time for each rated current as a function of RMS value of pre-arcing current I:

- Tolerances on this current ± 8%
- Beyond 30 sec, small overloads must be eliminated by another device.
- 

Curve CC' represents the maximum times taken by the associated device to clear small overloads; only its horizontal line is represented.

Its oblique line must be plotted according to sketch in top right corner:

- The intersection of the fuse and CC' curves indicates the minimum breaking current I<sub>pm</sub> of the fuse.

Size 0

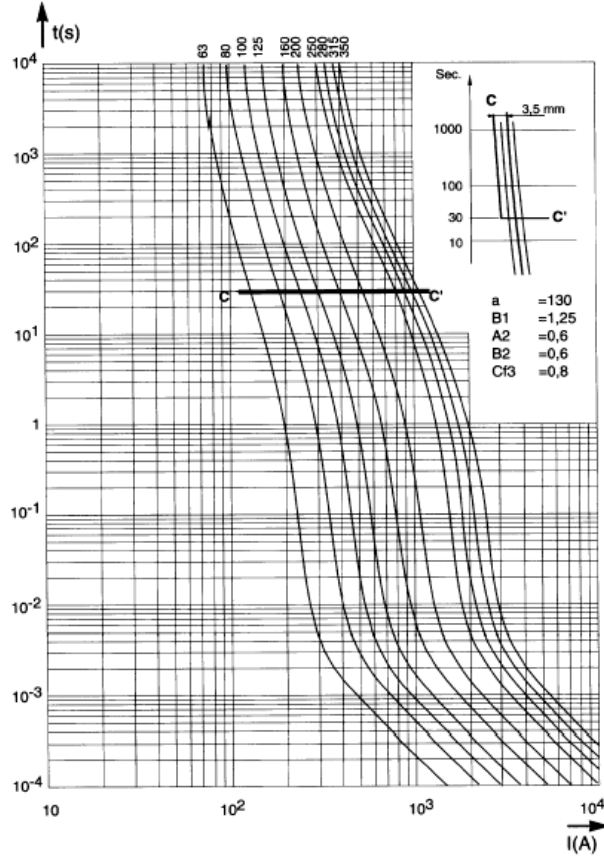

Size 1

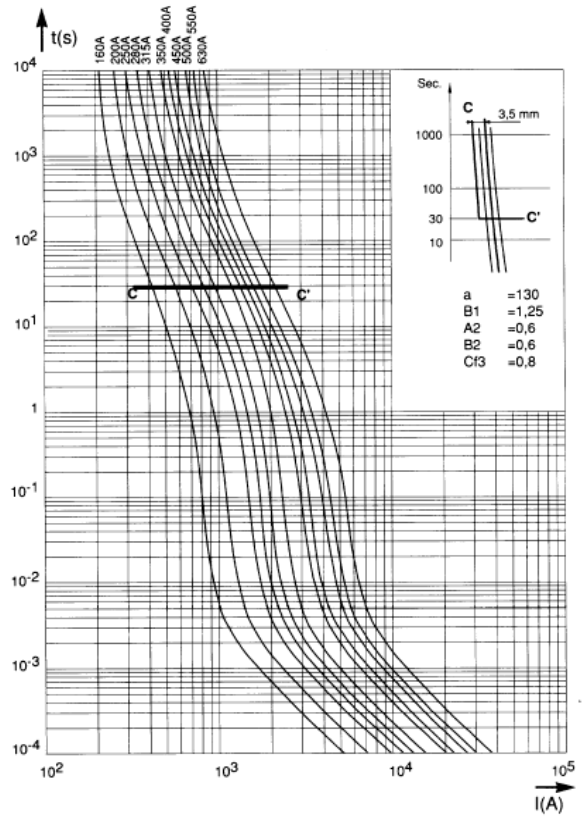

Size 2

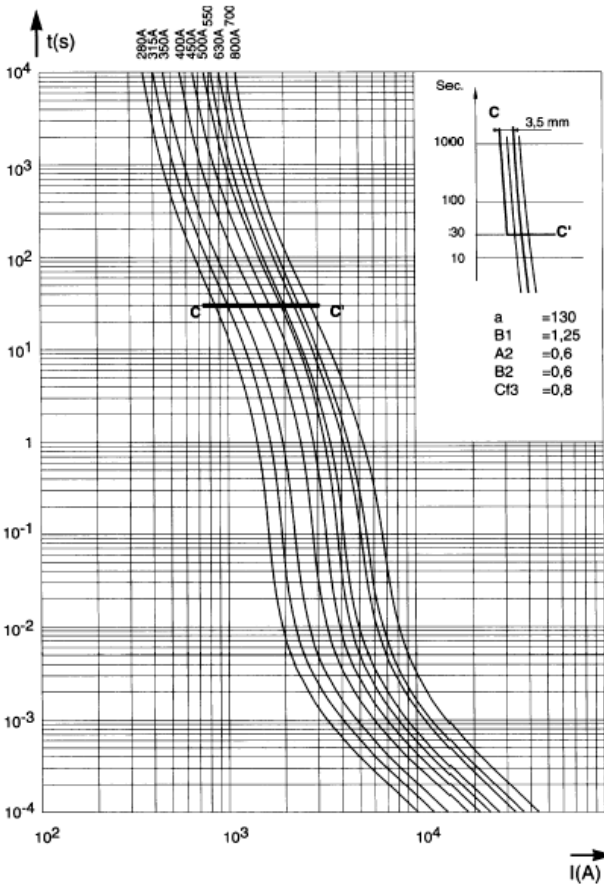

Size 3

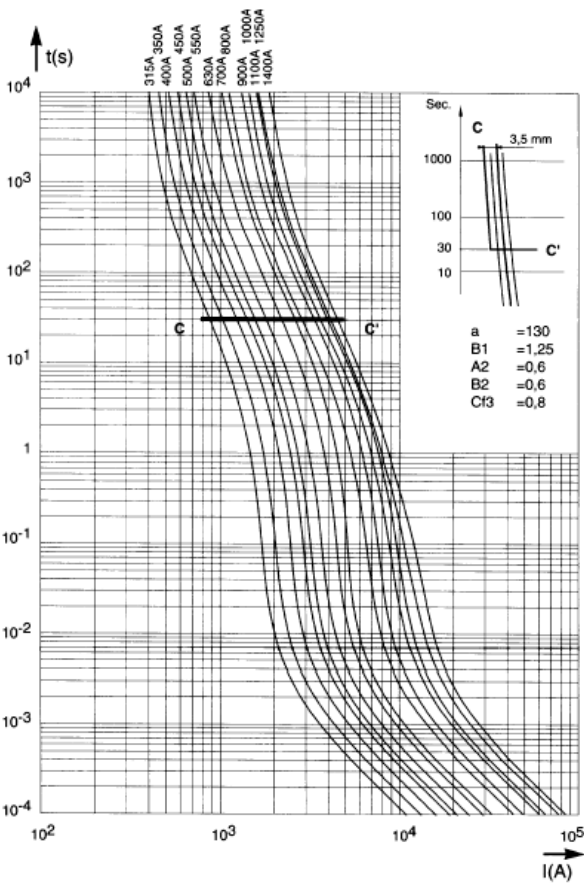



**Total clearing I<sup>2</sup>T:**

The horizontal curves given below indicate the maximum values of total operating I<sup>2</sup>t (I<sup>2</sup>t<sub>t</sub>) as a function of prospective current I<sub>p</sub> @ 1000V or 850V, cosφ = 0.15.

Oblique lines indicate the corresponding total operating time T<sub>t</sub>, with pre-arcing time in brackets.

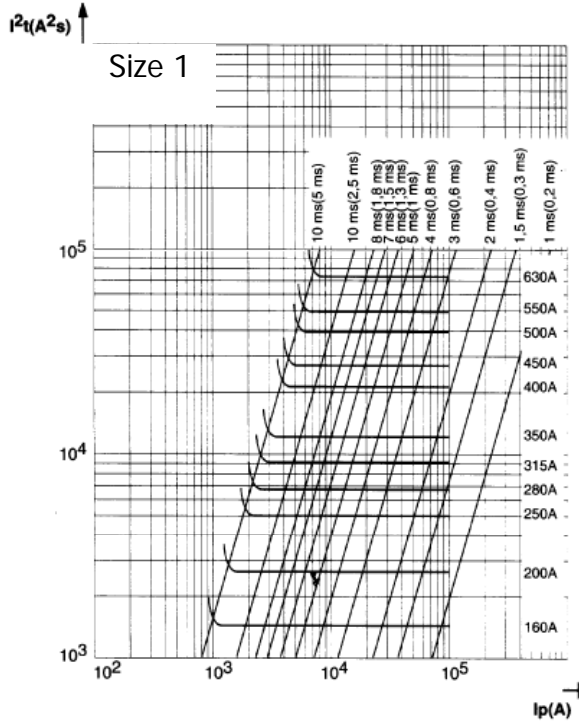
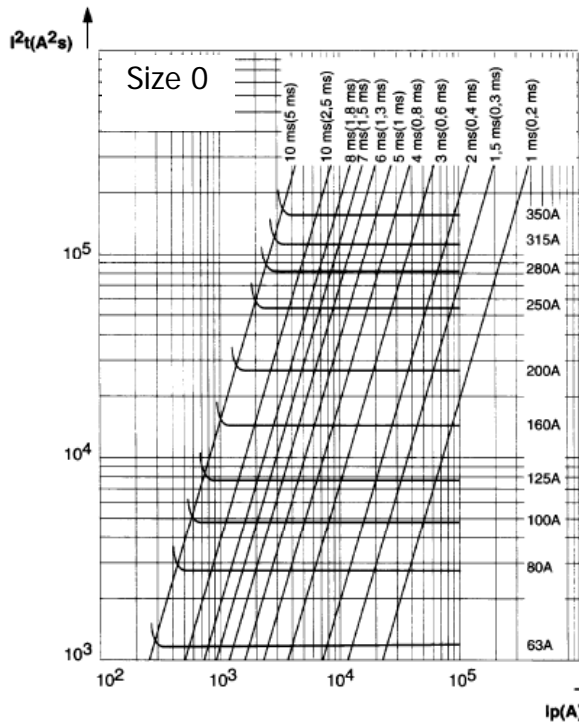

Curve currently unavailable

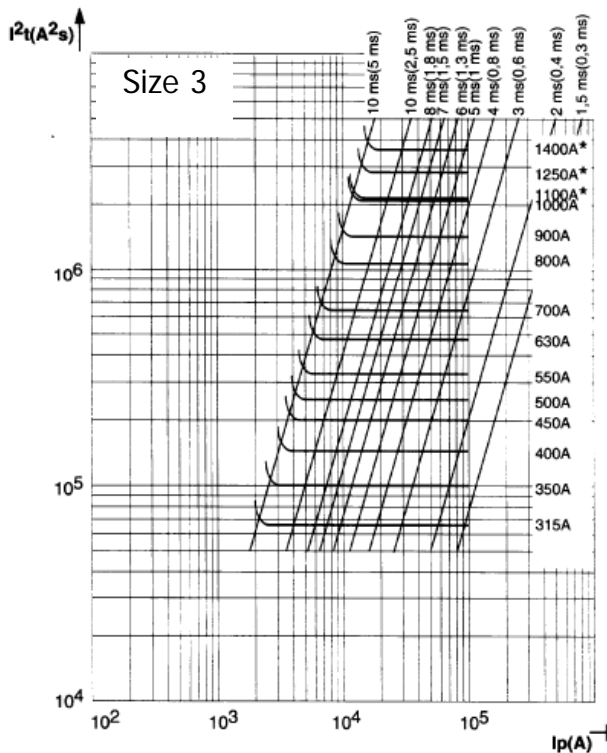

**Cut off Characteristics:**

The curves below indicate, for each rated current, the peak value  $I_c$  that the current may reach as a function of the prospective fault current  $I_p$ .

**Size 0**

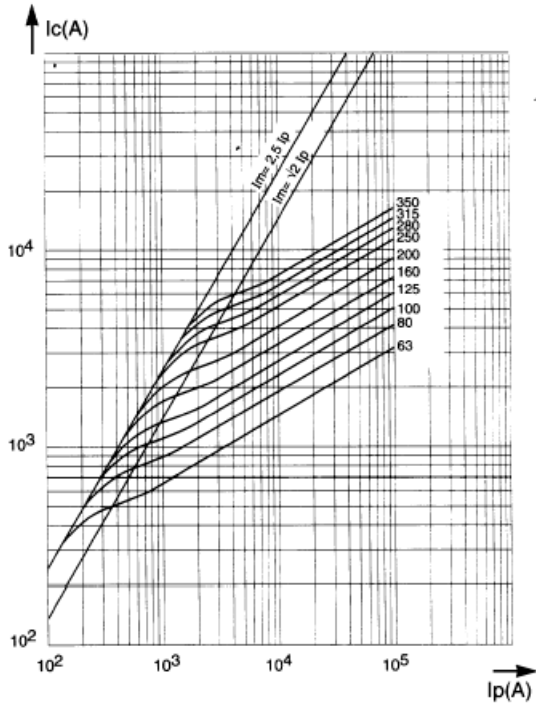

**Size 1**

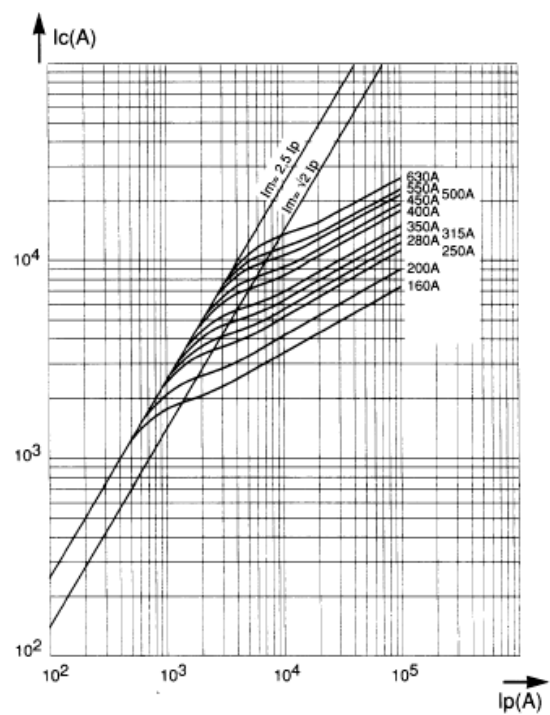

**Size 2**

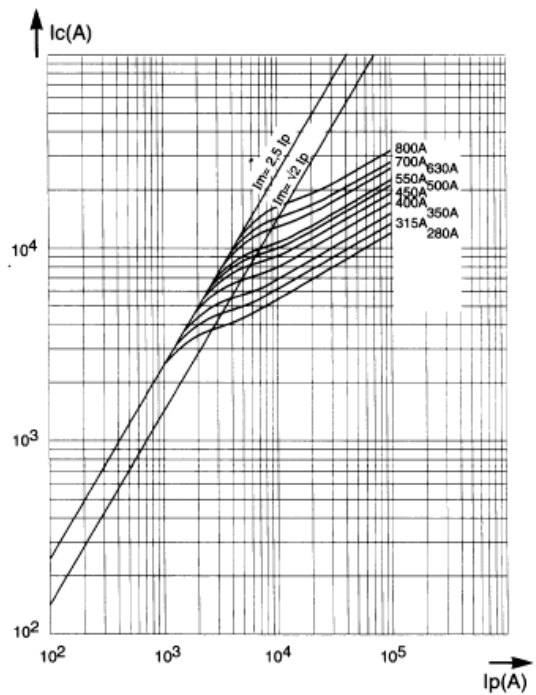

**Size 3**

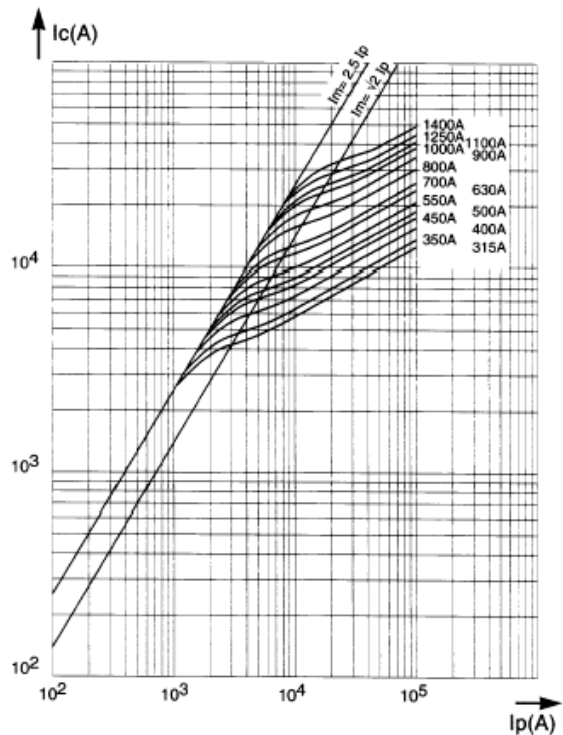

**Corrective Factor – Peak Arc Voltage:**

**Multiplier Coefficient:**

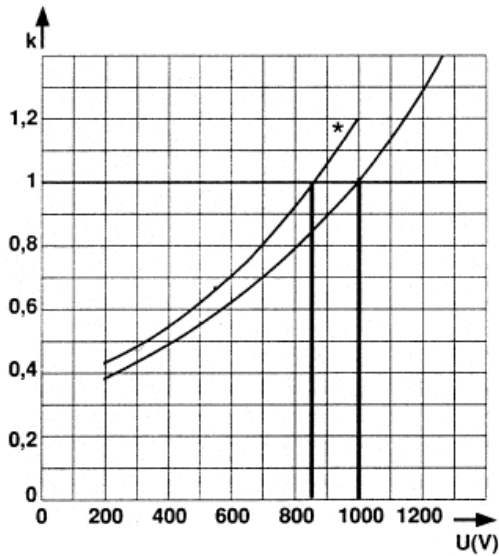

**Arc Voltage:**

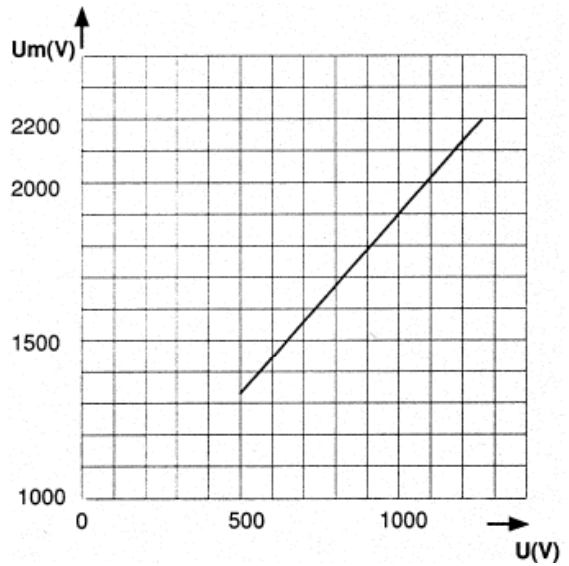

The above Mean curve shows variation of total  $I^2t$  ( $I^2t_t$ ) and total operating time  $T_t$  in accordance with working voltage  $U$ .

Curve indicating peak arc voltage  $U_m$  which may appear across fuse terminals as a function of working voltage  $U$  @  $\cos \varphi = 0.15$

**Dissipated Power:**

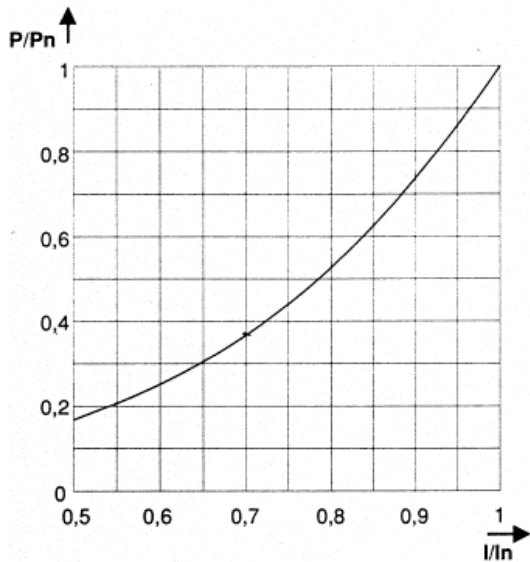

Curve enabling calculation of dissipated power  $P$  by a fuse rated  $I_N$ , as a function of the RMS current  $I$ , in multiples of  $I_N$ , in a steady state.

**Outline Drawing & Ordering Information**

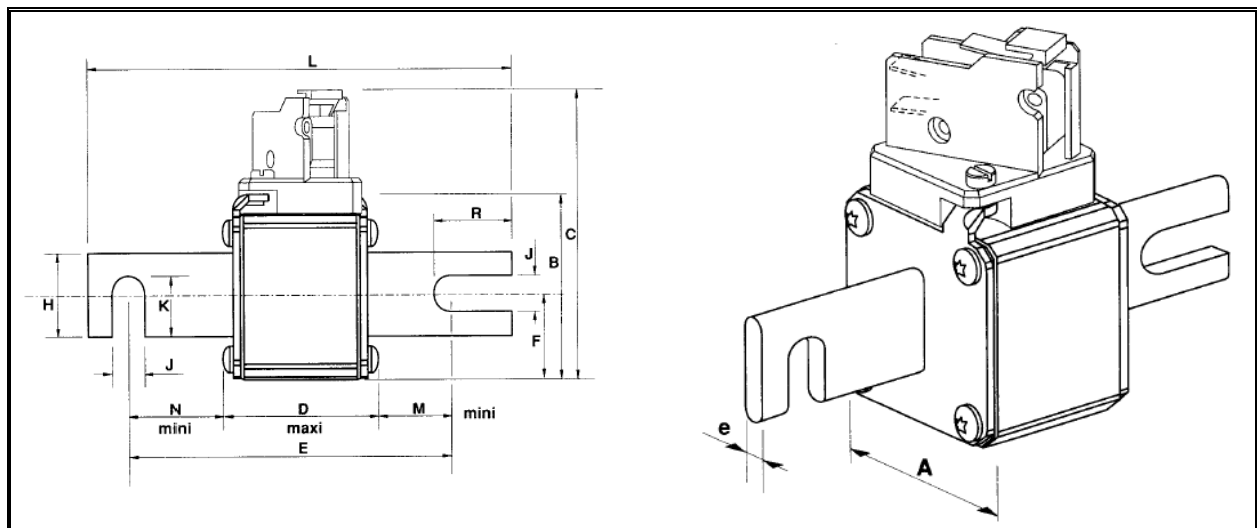

**Dimensions (mm)**

Size	A	B	C	D	E	L	F	H	J	K	M	N	R	e	Weight
0	40	46.5	82	71	100.4	133.4	21	25	10.5	17.7	11.5	18.5	25.2	6	380g
1	51	56.5	91	71	100.4	133.4	25.5	25	10.5	17.7	11.5	18.5	25.2	6	570g
2	60	65.5	100	71	100.4	133.4	30	32	10.5	21.2	11.5	18.5	25.2	6	800g
3	74.5	79.5	114	72	100.4	133.4	37.2	40	10.5	25.2	11	18	25.2	6	1150g

(\*) size 2 from 900A and size 3 from 1250A

**ORDERING INFORMATION**

(Please quote code as below)

Voltage Rating (V)	Type	Size	Fixing	Current Rating (A)	Indicator
900 – 1250	UR	0, 1, 2, 3	D	0063 – 1100	B

Order code: e.g. **125UR1D0350B** = 1250V, German Standard Square Body Fuse, Size 1, Din 110, 350A, with Button indicator.

**IXYS Semiconductor GmbH**  
 Edisonstraße 15  
 D-68623 Lampertheim  
 Tel: +49 6206 503-0  
 Fax: +49 6206 503-627  
 E-mail: [marcom@ixys.de](mailto:marcom@ixys.de)



An IXYS Company

**Westcode Semiconductors Ltd**  
 Langley Park Way Langley Park  
 Chippenham Wiltshire SN15 1GE  
 Tel: +44 (0)1249 444524  
 Fax: +44 (0)1249 659448  
 E-mail: [WSL.sales@westcode.com](mailto:WSL.sales@westcode.com)

**IXYS Corporation**  
 3540 Bassett Street  
 Santa Clara CA 95054 USA  
 Tel: +1 (408) 982 0700  
 Fax: +1 (408) 496 0670  
 E-mail: [sales@ixys.com](mailto:sales@ixys.com)

[www.westcode.com](http://www.westcode.com)

[www.ixys.com](http://www.ixys.com)

**Westcode Semiconductors Inc**  
 3270 Cherry Avenue  
 Long Beach CA 90807 USA  
 Tel: +1 (562) 595 6971  
 Fax: +1 (562) 595 8182  
 E-mail: [WSI.sales@westcode.com](mailto:WSI.sales@westcode.com)

The information contained herein is confidential and is protected by Copyright. The information may not be used or disclosed except with the written permission of and in the manner permitted by the proprietors Westcode Semiconductors Ltd.

© Westcode Semiconductors Ltd.

In the interest of product improvement, Westcode reserves the right to change specifications at any time without prior notice.

## Ultra Rapid Semiconductor Protection Fuse European Square Body Fuses - 690V

German Standard Din 80  
Voltage Rating - 690V  
Current Ratings from 16A to 160A  
gRB Characteristics  
Size 00



### Key Features:

- ❖ Extremely high breaking capacity fuses for the protection of power semiconductors as per IEC Standard 60269.1 and 4.
- ❖ 690V voltage rating complying with IEC 33
- ❖ Non Magnetic construction
- ❖ gRB Characteristics with ratings from 16 to 125A in accordance with VDE 636-23
  - Clearing all overloads
  - Improving safety and protection
  - Enabling selective co-ordination with all fuses
- ❖ All models available with or without integrated trip indicator
- ❖ Microswitch MS 4L 2-5 B
- ❖ Fuse holder SI 00 DIN80

**Main Characteristics:**

Size	Voltage U <sub>N</sub> (V)	Ref:	Micro Switch		Current rating I <sub>N</sub> (A)	Pre-arcing I <sup>2</sup> t @ 1 ms I <sup>2</sup> t <sub>p</sub> (A <sup>2</sup> s)	Total Clearing I <sup>2</sup> t @ U <sub>N</sub> (A <sup>2</sup> s)	Power Losses		Tested Interrupting rating
								0.8I <sub>N</sub>	I <sub>N</sub>	
00	690	069GSDA0016F	Y		16	8	61	2.7	5	200kA @ 690V
		069GSDA0020F	Y		20	12	86	3.3	6	
		069GSDA0025F	Y		25	18	140	4.4	8	
		069GSDA0032F	Y		32	39	250	6	11	
		069GSDA0040F	Y		40	68	450	7.1	13	
		069GSDA0050F	Y		50	116	750	8.8	16	
		069GSDA0063F	Y		63	210	1400	9.9	18	
		069GSDA0080F	Y		80	525	3000	10.5	19	
		069GSDA0100F	Y		100	970	5400	10.7	19.5	
		069GSDA0125F	Y		125	1710	9600	13.2	24	
		069GSDA0160F	Y		160	4270	22400	13.7	25	

Notes: Minimum operating voltage for integrated trip indicator = 20V

Micro switch reference: MS 4L 2-5 B6

**Electrical Characteristics:**

**Times vs Current Characteristics:**

These curves indicate, for each rated current, the pre-arcing time vs. the RMS pre-arcing current. Tolerance for the mean pre-arcing current ± 8%

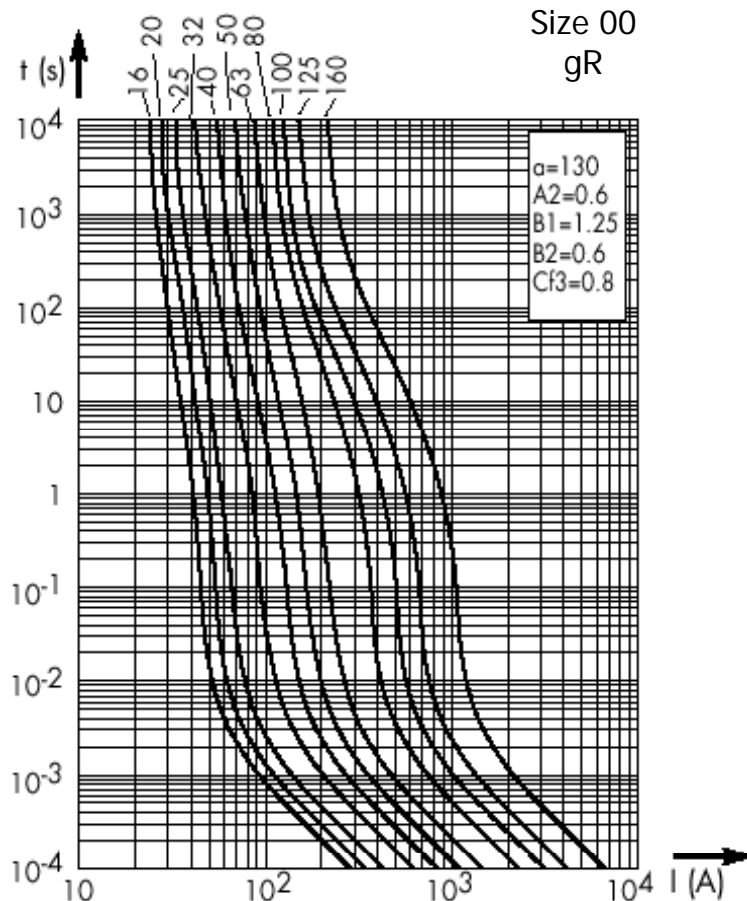

**Total Clearing  $I^2t$ :**

The horizontal curves show, for each rated current, values of total clearing  $I^2t(I^2t_t)$  as a function of prospective current  $I_p$  @  $U_N$  with  $\cos\phi = 0.15$ . Oblique lines indicate total clearing duration  $T_t$ , with associated pre-arcing duration in brackets.

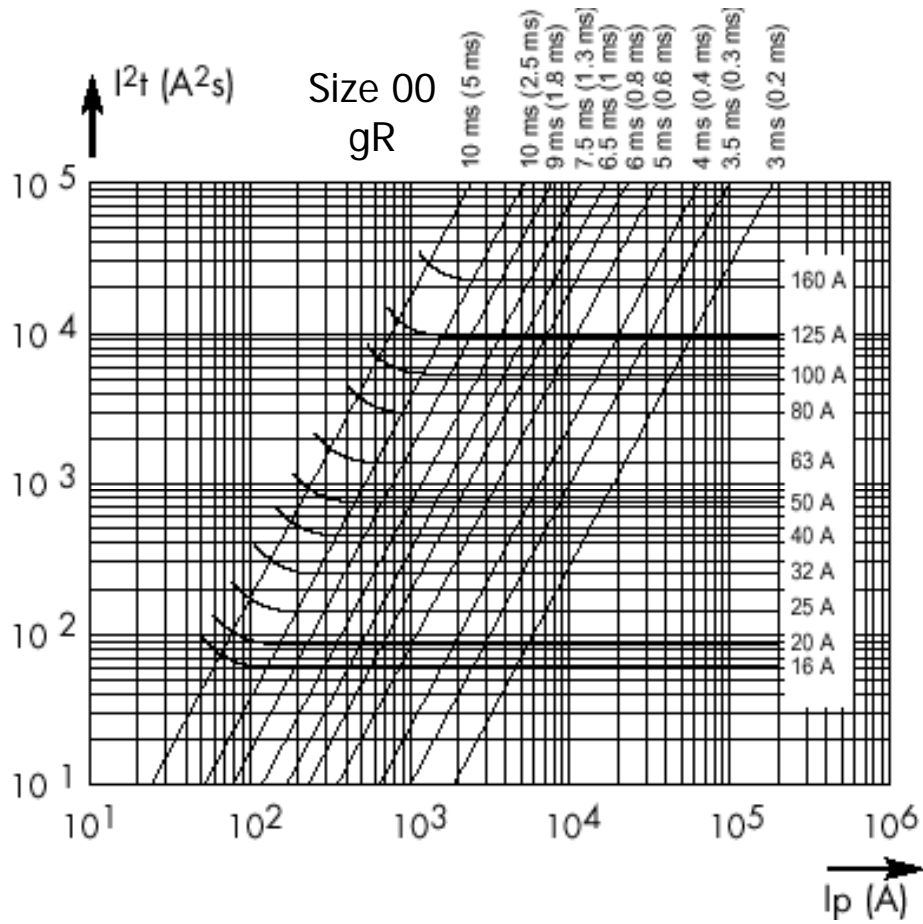

**Cut off Characteristics:**

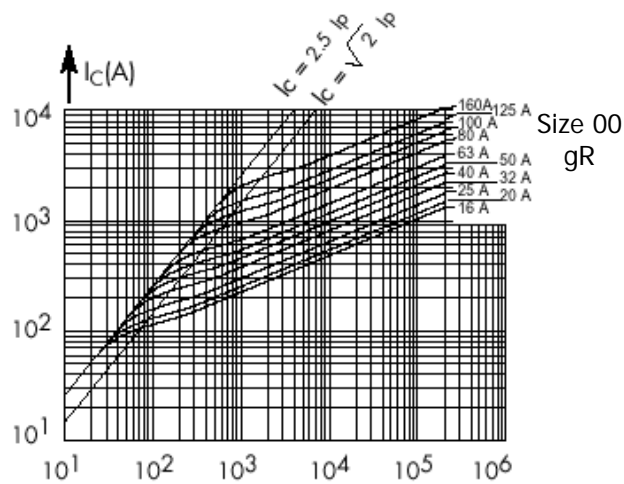

Curves show for each current rating value of peak let-through current  $I_c$  as a function of available fault current  $I_p$ .

**Corrective Factor:**

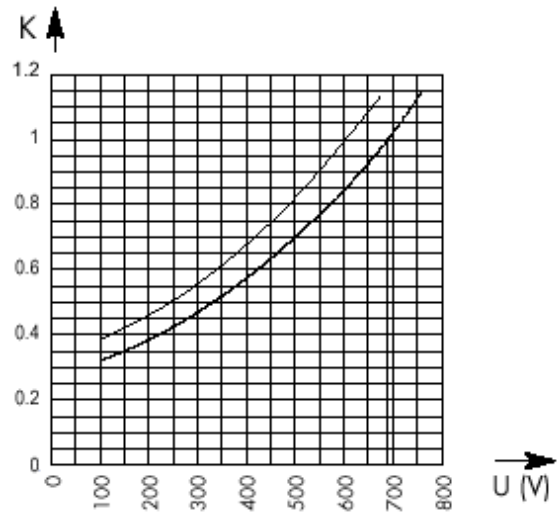

Mean curves show variation of total clearing time ( $I^2 t_1$ ) and total clearing duration  $T_1$  as a function of operating voltage  $U$ .

**Peak Arc Voltage:**

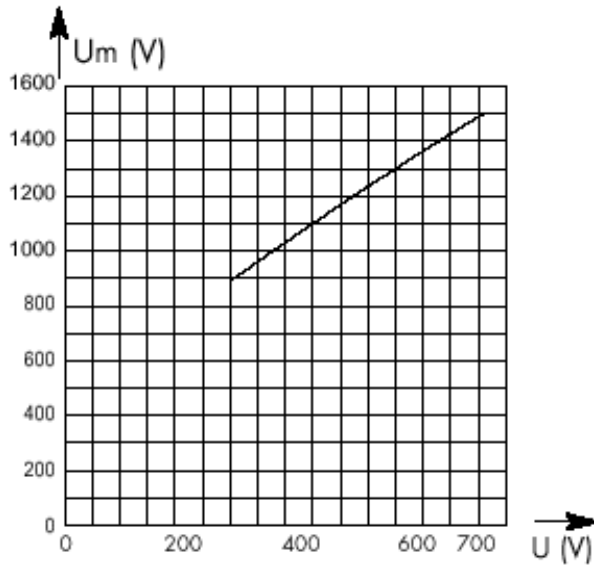

Curve shows peak value  $U_m$  of arc voltage which appears across fuse link as a function of the operating voltage  $U @ \cos \varphi = 0.15$

**Dissipated Power:**

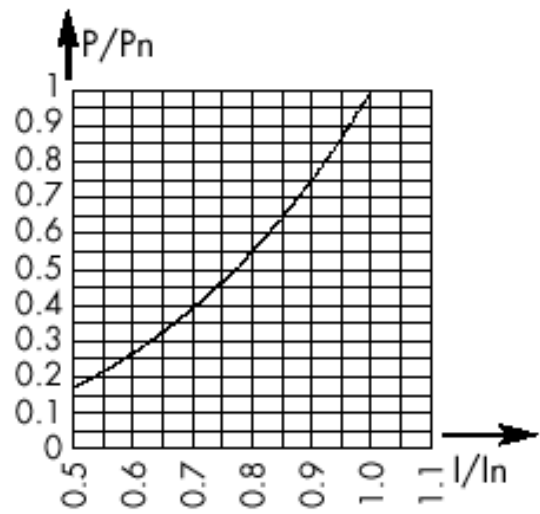

Curve enables computation of power losses  $P$  for a  $I_N$ -rated fuse as a function of RMS current  $I$  (as a multiple of  $I_N$  for steady state operation).



**Outline Drawing & Ordering Information:**

DIN 80 = GSDAxxxxN without trip indicator (140g)  
 GSDAxxxxF with trip indicator (190g)

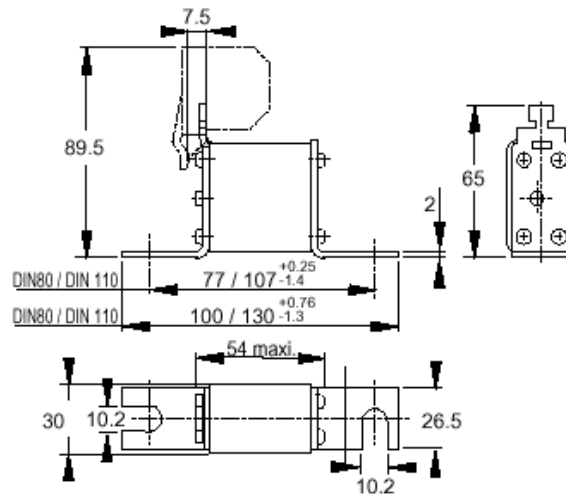

**ORDERING INFORMATION**

(Please quote code as below)

Voltage Rating (V)	Type	Size	Fixing	Current Rating (A)	Trip Indicator
690	GS	D	A	16 to 160	F

Order code: e.g. **690GSDA0063F** = 690V, German Standard Square Body, Size 00, 80mm, 63amp fuse with trip indicator switch

**IXYS Semiconductor GmbH**  
 Edisonstraße 15  
 D-68623 Lampertheim  
 Tel: +49 6206 503-0  
 Fax: +49 6206 503-627  
 E-mail: [marcom@ixys.de](mailto:marcom@ixys.de)

**WESTCODE**

An IXYS Company

**Westcode Semiconductors Ltd**  
 Langley Park Way Langley Park  
 Chippenham Wiltshire SN15 1GE  
 Tel: +44 (0)1249 444524  
 Fax: +44 (0)1249 659448  
 E-mail: [WSL.sales@westcode.com](mailto:WSL.sales@westcode.com)

**IXYS Corporation**  
 3540 Bassett Street  
 Santa Clara CA 95054 USA  
 Tel: +1 (408) 982 0700  
 Fax: +1 (408) 496 0670  
 E-mail: [sales@ixys.com](mailto:sales@ixys.com)

[www.westcode.com](http://www.westcode.com)

[www.ixys.com](http://www.ixys.com)

**Westcode Semiconductors Inc**  
 3270 Cherry Avenue  
 Long Beach CA 90807 USA  
 Tel: +1 (562) 595 6971  
 Fax: +1 (562) 595 8182  
 E-mail: [WSI.sales@westcode.com](mailto:WSI.sales@westcode.com)

The information contained herein is confidential and is protected by Copyright. The information may not be used or disclosed except with the written permission of and in the manner permitted by the proprietors Westcode Semiconductors Ltd.

© Westcode Semiconductors Ltd.

In the interest of product improvement, Westcode reserves the right to change specifications at any time without prior notice.

## Ultra Rapid Semiconductor Protection Fuse

European Square Body Fuses 690V

















German Standard DIN 80  
Voltage Rating - 690V  
Current Ratings from 16A to 450A  
aR Characteristics  
Size 00



### Key Features:

- ❖ Extremely high breaking capacity fuses for the protection of power semiconductors as per IEC Standard 60269.1 and 4.
- ❖ 690V voltage rating complying with IEC 33
- ❖ Non Magnetic construction
- ❖ gRB Characteristics with ratings from 16 to 125A in accordance with VDE 636-23
  - Clearing all overloads
  - Improving safety and protection
  - Enabling selective co-ordination with all fuses
- ❖ All models available with or without integrated trip indicator
- ❖ Microswitch MS 4L 2-5 B6
- ❖ Fuse holder SI 00 DIN80

**Main Characteristics:**

Size	Voltage U <sub>N</sub> (V)	Ref:	Micro Switch		Current rating I <sub>N</sub> (A)	Pre-arcing I <sup>2</sup> t @ 1 ms I <sup>2</sup> t <sub>p</sub> (A <sup>2</sup> s)	Total Clearing I <sup>2</sup> t @ U <sub>N</sub> (A <sup>2</sup> s)	Power Losses		Tested Interrupting rating
								0.8I <sub>N</sub>	I <sub>N</sub>	
00	690V	069GUDA0016F	Y		16	7	52	3.8	7	200kA @ 690V
		069GUDA0020F	Y		20	10	75	5	9	
		069GUDA0025F	Y		25	15	120	6	11	
		069GUDA0032F	Y		32	32	210	8.2	15	
		069GUDA0040F	Y		40	61	400	9.9	18	
		069GUDA0050F	Y		50	102	700	11.5	21	
		069GUDA0063F	Y		63	177	1200	12.6	23	
		069GUDA0080F	Y		80	390	2200	13.8	25	
		069GUDA0100F	Y		100	692	3900	15.4	28	
		069GUDA0125F	Y		125	1170	6600	18.1	33	
		069GUDA0160F	Y		160	2680	14000	19.8	36	
		069GUDA0200F	Y		200	4690	24000	23.1	42	
		069GUDA0250F	Y		250	8300	42500	27.5	50	
		069GUDA0315F	Y		315	17520	81000	31.9	58	
		069GUDA0350F	Y		350	25450	118000	33	60	
	069GUDA0400F	Y		400	33200	150000	38.5	70		
600V	060GUDA0450F	Y		450	19600	225000	40.7	74	200kA @ 600V	

Notes: Minimum operating voltage for integrated trip indicator = 20V

Micro switch reference : MS 4L 2-5 B6 

Electrical Characteristics:

**Times vs Current Characteristics:**

These curves indicate, for each rated current, the pre-arcing time vs. the RMS pre-arcing current. Tolerance for the mean pre-arcing current  $\pm 8\%$

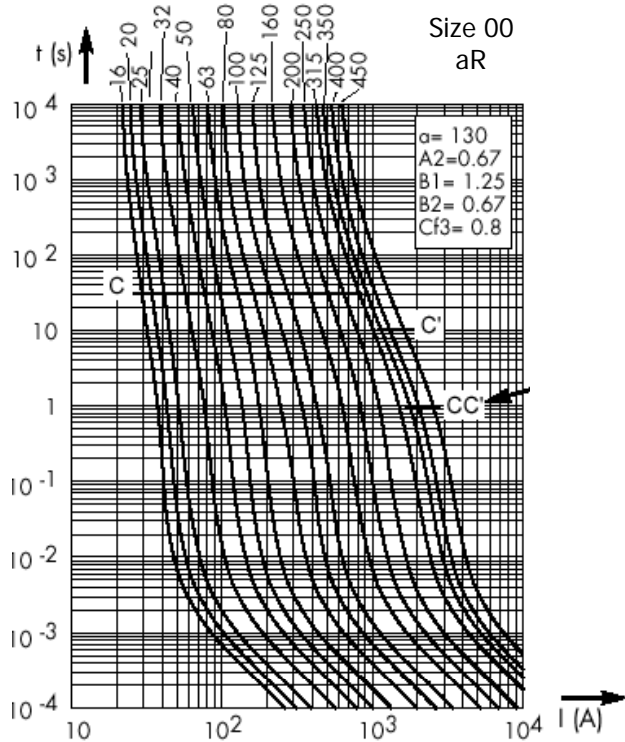

**Total Clearing  $I^2t$ :**

The horizontal curves show, for each rated current, values of total clearing  $I^2t (I^2t_t)$  as a function of prospective current  $I_p @ U_N$  with  $\cos\phi = 0.15$ . Oblique lines indicate total clearing duration  $Tt$ , with associated pre-arcing duration in brackets.

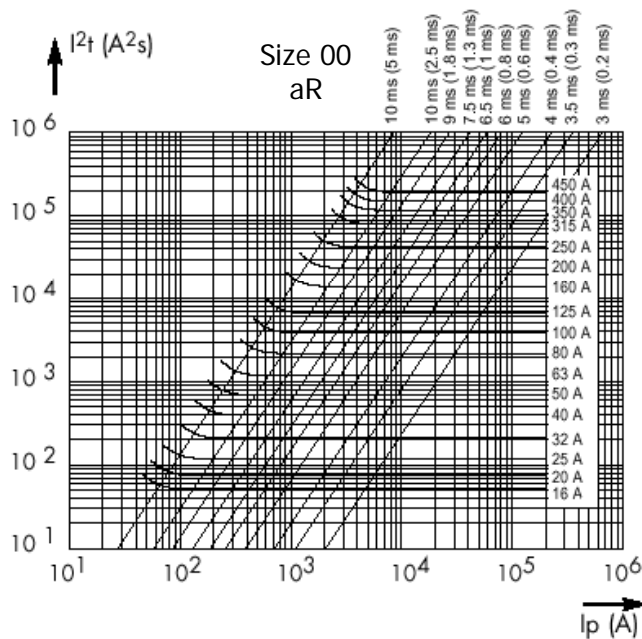

**Cut off Characteristics:**

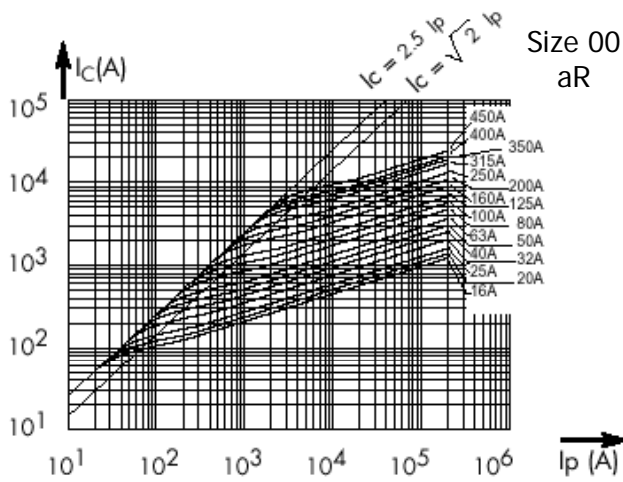

Curves show for each current rating value of peak let-through current  $I_c$  as a function of available fault current  $I_p$

**Corrective Factor:**

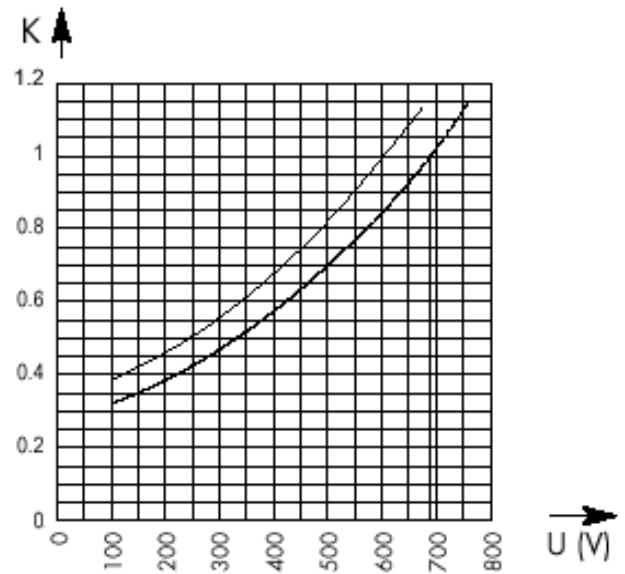

Mean curves show variation of total clearing time ( $I^2 t$ ) and total clearing duration  $T_t$  as a function of operating voltage  $U$ .

**Peak Arc Voltage:**

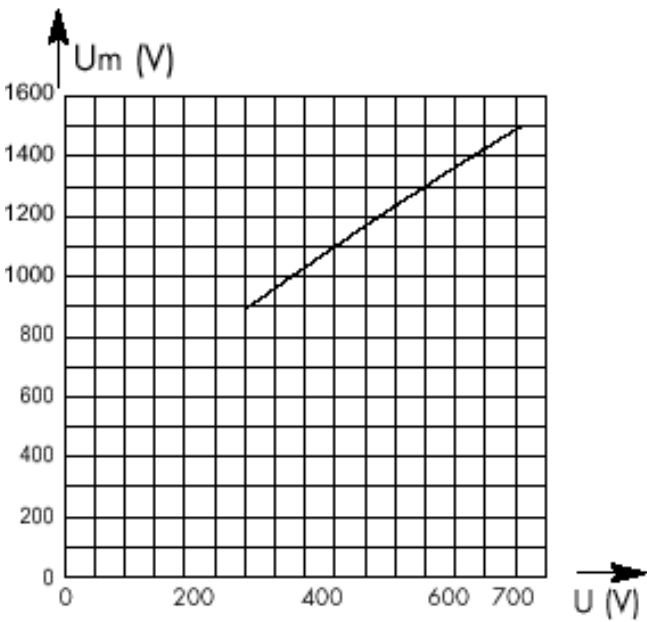

Curve shows peak value  $U_m$  of arc voltage which appears across fuse link as a function of the operating voltage  $U @ \cos \varphi = 0.15$

**Dissipated Power:**

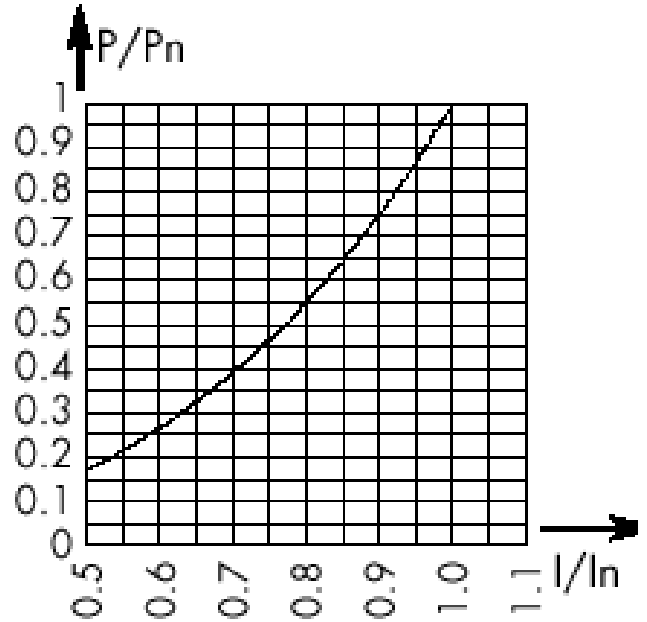

Curve enables computation of power losses  $P$  for a  $I_N$ -rated fuse as a function of RMS current  $I$  (as a multiple of  $I_N$  for steady state operation).

**Outline Drawing & Ordering Information:**

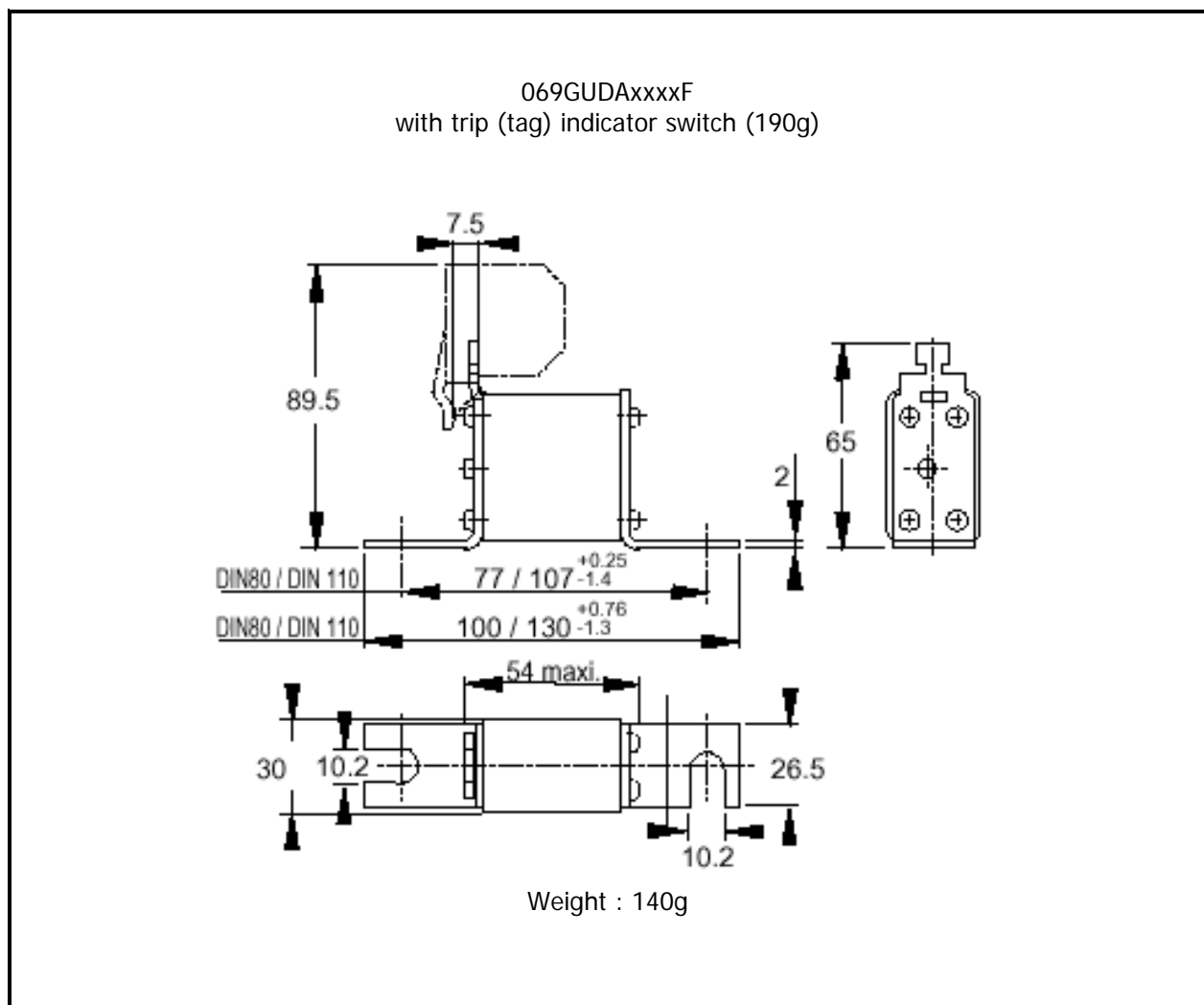

**ORDERING INFORMATION**

(Please quote code as below)

Voltage Rating (V)	Type	Size	Fixing	Current Rating (A)	Trip Indicator
690	GU	D	A	16 to 450	F

Order code: e.g. **069GUDA0050F** = 690V German Standard, Size 00, 80mm fixing, 50amp fuse with trip (tag) indicator switch

**IXYS Semiconductor GmbH**  
Edisonstraße 15  
D-68623 Lampertheim  
Tel: +49 6206 503-0  
Fax: +49 6206 503-627  
E-mail: [marcom@ixys.de](mailto:marcom@ixys.de)

WESTCODE

An IXYS Company

**Westcode Semiconductors Ltd**  
Langley Park Way Langley Park  
Chippenham Wiltshire SN15 1GE  
Tel: +44 (0)1249 444524  
Fax: +44 (0)1249 659448  
E-mail: [WSL.sales@westcode.com](mailto:WSL.sales@westcode.com)

**IXYS Corporation**  
3540 Bassett Street  
Santa Clara CA 95054 USA  
Tel: +1 (408) 982 0700  
Fax: +1 (408) 496 0670  
E-mail: [sales@ixys.com](mailto:sales@ixys.com)

[www.westcode.com](http://www.westcode.com)

[www.ixys.com](http://www.ixys.com)

**Westcode Semiconductors Inc**  
3270 Cherry Avenue  
Long Beach CA 90807 USA  
Tel: +1 (562) 595 6971  
Fax: +1 (562) 595 8182  
E-mail: [WSI.sales@westcode.com](mailto:WSI.sales@westcode.com)

The information contained herein is confidential and is protected by Copyright. The information may not be used or disclosed except with the written permission of and in the manner permitted by the proprietors Westcode Semiconductors Ltd.

© Westcode Semiconductors Ltd.

In the interest of product improvement, Westcode reserves the right to change specifications at any time without prior notice.

## Ultra Rapid Semiconductor Protection Fuse

European Square Body Type Fuses – 700V

**German Standard DIN 80  
Voltage Rating from 500V to 700V  
Current Rating from 80A to 400A  
aR Characteristics  
Size 000**



### **Key Features:**

- ❖ Extremely high interrupting rating fuses for the protection of power semiconductors according to 60269.1 and 4
- ❖ 690V voltage rating for currents ratings of 20A to 400A
- ❖ Non Magnetic construction
- ❖ aR Characteristics with ratings from 80 to 400A according to VDE 636-23 and IEC 60269.4
- ❖ All models comply with DIN80 standard with blown fuse indication, available with or without trip indicator.
- ❖ Microswitch system reference : MS 4L 2-5 B6+PRES

**Main Characteristics:**

**German Standard DIN 80, aR, Size 000 with indicator, silicated.**

Voltage Rating U <sub>N</sub> (V)	Ref:	Micro Switch		Current rating I <sub>N</sub> (A)	Pre-arcing I <sup>2</sup> t @ 1 ms I <sup>2</sup> t <sub>p</sub> (A <sup>2</sup> s)	Total Clearing I <sup>2</sup> t @ U <sub>N</sub> I <sup>2</sup> t <sub>t</sub> (A <sup>2</sup> s)	Power Losses		Tested Interrupting rating
							0.8I <sub>N</sub>	I <sub>N</sub>	
690V	070GQCA0080F	N		80	390	2500	11.6	21	200kA @ 690V
	070GQCA0100F	N		100	690	4200	12.7	23	
	070GQCA0125F	N		125	1300	8900	14.3	26	
	070GQCA0160F	N		160	2700	16000	17	31	
	070GQCA0200F	N		200	5250	31500	19.8	36	
	070GQCA0250F	N		250	9900	52000	24.8	45	
690V +6%	070GQCA0315F	N		315	15500	82000	31.9	58	
500V	050GQCA0350F	N		350	22400	110000	31.9	58	120Ka @ 500V
	050GQCA0400F	N		400	33200	160000	36.3	66	

Note: Minimum operating voltage for integrated trip indicator = 20V

**German Standard DIN 80, aR, Size 000 without indicator, silicated.**

Voltage Rating U <sub>N</sub> (V)	Ref:	MC		Current rating I <sub>N</sub> (A)	Pre-arcing I <sup>2</sup> t @ 1 ms I <sup>2</sup> t <sub>p</sub> (A <sup>2</sup> s)	Total Clearing I <sup>2</sup> t @ U <sub>N</sub> I <sup>2</sup> t <sub>t</sub> (A <sup>2</sup> s)	Power Losses		Tested Interrupting rating
							0.8I <sub>N</sub>	I <sub>N</sub>	
690V	070GQCA0080N	N		80	390	2500	11.6	21	200kA @ 690V
	070GQCA0100N	N		100	690	4200	12.7	23	
	070GQCA0125N	N		125	1300	8900	14.3	26	
	070GQCA0160N	N		160	2700	16000	17.0	31	
	070GQCA0200N	N		200	5250	31500	19.8	36	
	070GQCA0250N	N		250	9900	52000	24.8	45	
690V +6%	070GQCA0315N	N		315	15500	82000	31.9	58	
500V	050GQCA0350N	N		350	22400	110000	31.9	58	120Ka @ 500V
	050GQCA0400N	N		400	33200	160000	36.3	66	

**German Standard DIN 80, aR, Size 000 Trip (Tag) Indicator, micro switch capable, non-silicated.**

Voltage Rating U <sub>N</sub> (V)	Ref:	MC		Current rating I <sub>N</sub> (A)	Pre-arcing I <sup>2</sup> t @ 1 ms I <sup>2</sup> t <sub>p</sub> (A <sup>2</sup> s)	Total Clearing I <sup>2</sup> t @ U <sub>N</sub> I <sup>2</sup> t <sub>t</sub> (A <sup>2</sup> s)	Watt Losses		Tested Interrupting rating
							0.8I <sub>N</sub>	I <sub>N</sub>	
690V	070GTCA0080F	Y		80	390	2500	11.6	21	200kA @ 660V
	070GTCA0100F	Y		100	690	4200	12.7	23	
	070GTCA0125F	Y		125	1300	8900	14.3	26	
	070GTCA0160F	Y		160	2700	16000	17	31	
	070GTCA0200F	Y		200	5250	31500	19.8	36	
	070GTCA0250F	Y		250	9900	52000	24.8	45	
690V +6%	070GTCA0315F	Y		315	15500	82000	31.9	58	
500V	050GTCA0350F	Y		350	22400	110000	31.9	58	120Ka @ 500V
	050GTCA0400F	Y		400	33200	160000	36.3	66	

Notes: Minimum operating voltage for integrated trip indicator = 20V  
 DIN80 aR Size 000 - 070GTCAxxxxF with blow fuse trip indicator may be adapted to use Micro switch ref: MS 4L 2-5 B6



**Electrical Characteristics:**

**Times vs current characteristics:**

The curve below shows, for each rating, value of peak let-through current  $I_c$  as a function of available fault current  $I_p$ . Tolerance for mean pre-arcing current  $\pm 8\%$ .

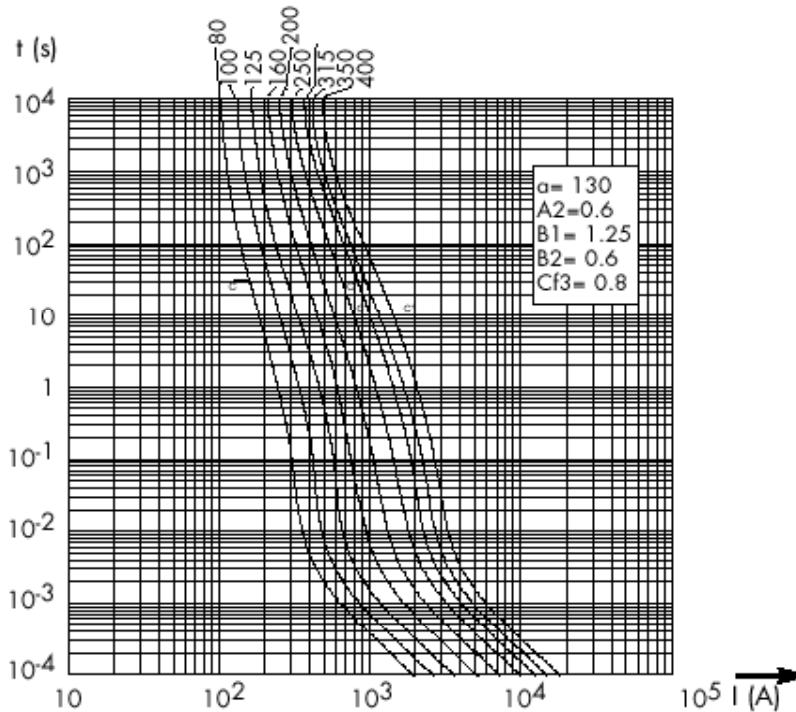

**Total Clearing  $I^2t$**

The horizontal curves show, for each rated current, values of total clearing  $I^2t(I^2t_c)$  as a function of prospective current  $I_p$  @  $U_N$  with  $\cos\phi = 0.15$ . Oblique lines indicate total clearing duration  $T_t$ , with associated pre-arcing duration in brackets.

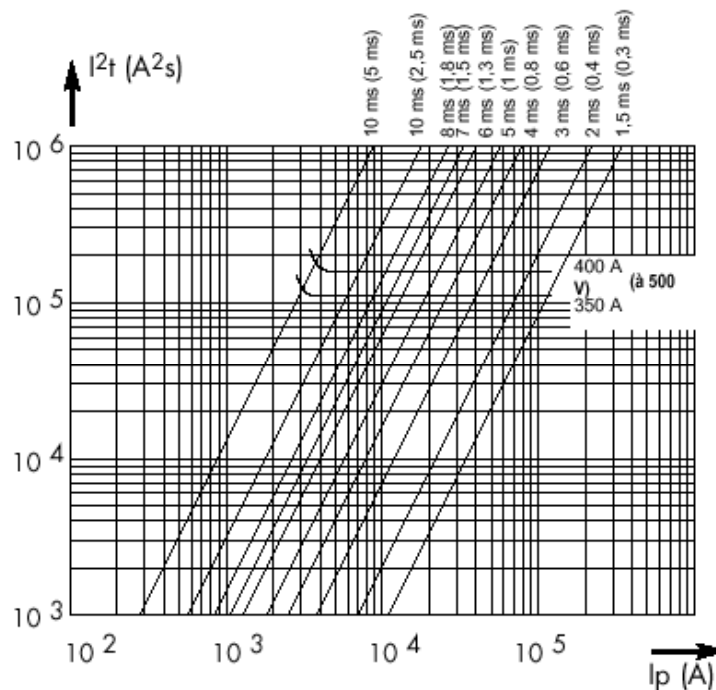

**Current Limitation Curve**

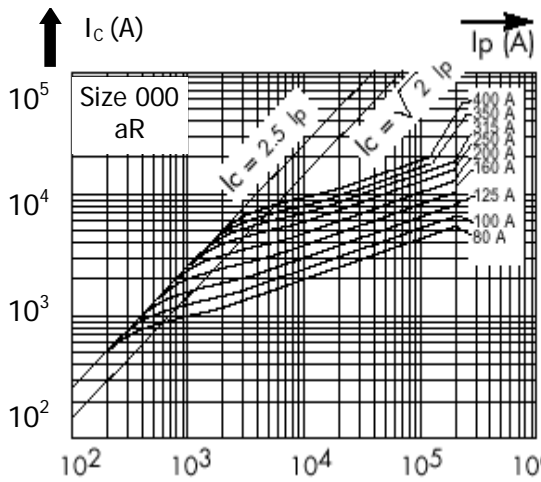

Curves show for each current rating value of peak let-through current  $I_c$  as a function of available fault current  $I_p$

**$I^2t$  Corrective Factor**

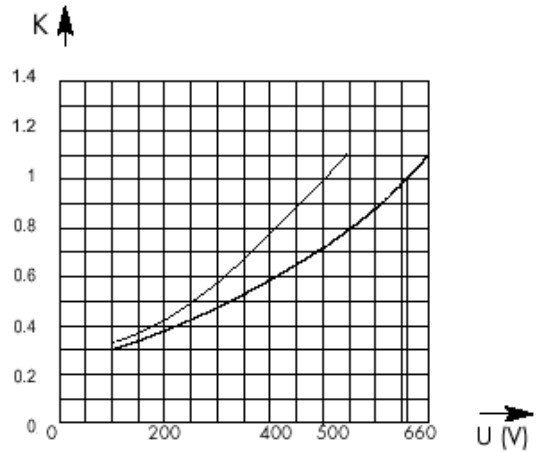

Mean curves show variation of total clearing time ( $I^2t_t$ ) and total clearing duration  $T_t$  as a function of operating voltage  $U$ .

**Peak Arc Voltage**

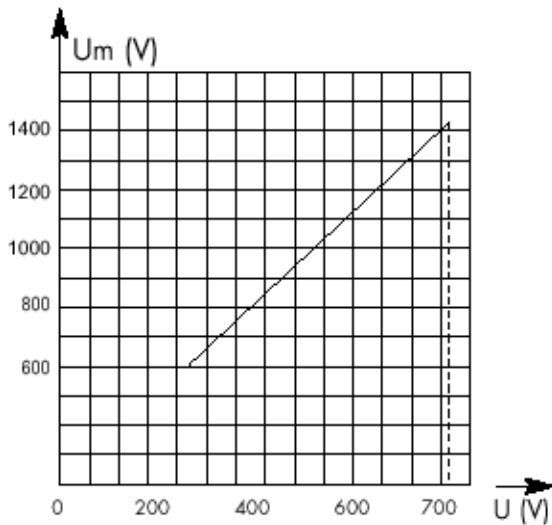

Curve shows peak value  $U_m$  of arc voltage which appears across fuse link as a function of the operating voltage  $U @ \cos \varphi = 0.15$

**Power Loss**

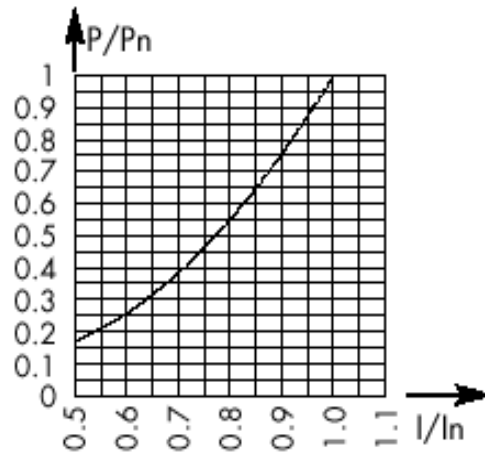

Curve enables computation of power losses  $P$  for a  $I_N$ -rated fuse as a function of RMS current  $I$  (as a multiple of  $I_N$  for steady state operation).

**Outline Drawing & Ordering Information:**

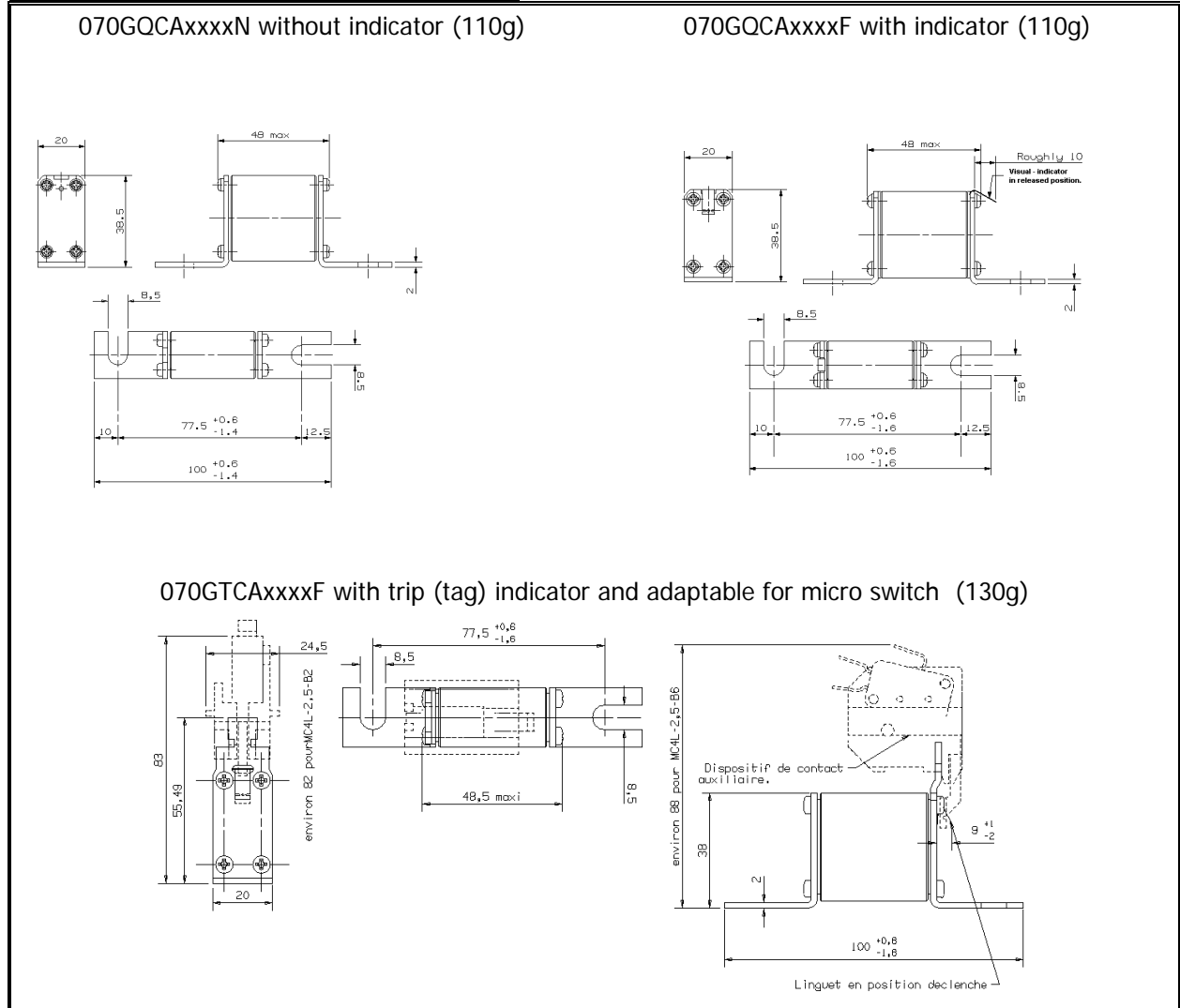

**ORDERING INFORMATION**

(Please quote code as below)

Voltage Rating (V)	Type	Size	80mm Fixing	Current Rating (A)	Indicator
500 – 700	GQ / GT	C	A	0080 - 0400	F / N

**Order code:** e.g. 070GTCA0080F = 700V, German Standard, DIN 80, 80A with trip (tag) indicator.

**IXYS Semiconductor GmbH**  
 Edisonstraße 15  
 D-68623 Lampertheim  
 Tel: +49 6206 503-0  
 Fax: +49 6206 503-627  
 E-mail: [marcom@ixys.de](mailto:marcom@ixys.de)



**Westcode Semiconductors Ltd**  
 Langley Park Way Langley Park  
 Chippenham Wiltshire SN15 1GE  
 Tel: +44 (0)1249 444524  
 Fax: +44 (0)1249 659448  
 E-mail: [WSL.sales@westcode.com](mailto:WSL.sales@westcode.com)

**IXYS Corporation**  
 3540 Bassett Street  
 Santa Clara CA 95054 USA  
 Tel: +1 (408) 982 0700  
 Fax: +1 (408) 496 0670  
 E-mail: [sales@ixys.com](mailto:sales@ixys.com)

[www.westcode.com](http://www.westcode.com)

[www.ixys.com](http://www.ixys.com)

**Westcode Semiconductors Inc**  
 3270 Cherry Avenue  
 Long Beach CA 90807 USA  
 Tel: +1 (562) 595 6971  
 Fax: +1 (562) 595 8182  
 E-mail: [WSI.sales@westcode.com](mailto:WSI.sales@westcode.com)

The information contained herein is confidential and is protected by Copyright. The information may not be used or disclosed except with the written permission of and in the manner permitted by the proprietors Westcode Semiconductors Ltd.

© Westcode Semiconductors Ltd.

In the interest of product improvement, Westcode reserves the right to change specifications at any time without prior notice.

# WESTCODE

An IXYS Company

Date:- 18 Mar, 2005

Data Sheet Issue:- 1

## Ultra Rapid Semiconductor Protection Fuse

European Square Body Type Fuses  
German Standard DIN 80 Knife Blade  
Voltage Ratings - 660 to 690V+6%  
Current Ratings from 80A to 400A  
gR / aR Characteristics  
Size 000



### Key Features:

- ❖ Extremely high interrupting rating fuses for the protection of power semiconductors according to 60269.1 and 4
- ❖ 500V – 690V voltage rating complying with IEC 33
- ❖ Non Magnetic construction
- ❖ gR Characteristics with current ratings from 20A to 125A according to VDE 636-23
  - clearing all overloads
  - improving safety and protection
  - enabling selective co-ordination with all fuses
- ❖ aR Characteristics with current ratings from 80A to 400A in accordance with VDE 636-23 and IEC 60269.4 standards
- ❖ All models comply with DIN80 standard with blown fuse indication, with trip indicator.
- ❖ Microswitch reference MS 4L 2-5 B6

**Main Characteristics:**

**German Standard DIN80, gR, Size 000 with indicator, silicated.**

Voltage Rating $U_N$ (V)	Ref:	Micro Switch		Current rating $I_N$ (A)	Pre-arcing $I^2t @ 1 \text{ ms}$ $I^2t_p$ (A <sup>2</sup> s)	Total Clearing $I^2t @ U_N$ $I^2t_t$ (A <sup>2</sup> s)	Power Losses		Tested Interrupting rating
							$0.8I_N$	$I_N$	
690V	070GGCA0020F	N		20	12	80	3.8	7	200kA @690V
	070GGCA0025F	N		25	20	150	5	9	
	070GGCA0032F	N		32	39	270	5.5	10	
	070GGCA0040F	N		40	70	460	6.6	12	
	070GGCA0050F	N		50	102	730	7.7	14	
	070GGCA0063F	N		63	210	1500	8.8	16	
	070GGCA0080F	N		80	475	2900	9.9	18	
	070GGCA0100F	N		100	970	6000	11	20	
070GGCA0125F	N		125	1900	11800	11.6	21		

Note: Minimum operating voltage for integrated trip indicator = 20V

**German Standard DIN80, gR, Size 000 without indicator, silicated.**

Voltage Rating $U_N$ (V)	Ref:	Micro Switch		Current rating $I_N$ (A)	Pre-arcing $I^2t @ 1 \text{ ms}$ $I^2t_p$ (A <sup>2</sup> s)	Total Clearing $I^2t @ U_N$ $I^2t_t$ (A <sup>2</sup> s)	Power Losses		Tested Interrupting rating
							$0.8I_N$	$I_N$	
690V	070GGCA0020N	N		20	12	80	3.8	7	200kA @ 690V
	070GGCA0025N	N		25	20	150	5	9	
	070GGCA0032N	N		32	39	270	5.5	10	
	070GGCA0040N	N		40	70	460	6.6	12	
	070GGCA0050N	N		50	102	730	7.7	14	
	070GGCA0063N	N		63	210	1500	8.8	16	
	070GGCA0080N	N		80	475	2900	9.9	18	
	070GGCA0100N	N		100	970	6000	11	20	
070GGCA0125N	N		125	1900	11800	11.6	21		

**German Standard DIN80, gR, Size 000 with trip (Tag) indicator, micro switch capable, non-silicated.**

Voltage Rating $U_N$ (V)	Ref:	Micro Switch		Current rating $I_N$ (A)	Pre-arcing $I^2t @ 1 \text{ ms}$ $I^2t_p$ (A <sup>2</sup> s)	Total Clearing $I^2t @ U_N$ $I^2t_t$ (A <sup>2</sup> s)	Power Losses		Tested Interrupting rating
							$0.8I_N$	$I_N$	
660V 690+6%	070GSCA0020F	Y		20	12	80	3.8	7	200kA @ 660V
	070GSCA0025F	Y		25	20	150	5.0	9	
	070GSCA0032F	Y		32	39	270	5.5	10	
	070GSCA0040F	Y		40	70	460	6.6	12	
	070GSCA0050F	Y		50	102	730	7.7	14	
	070GSCA0063F	Y		63	210	1500	8.8	16	
	070GSCA0080F	Y		80	475	2900	9.9	18	
	070GSCA0100F	Y		100	970	6000	11.0	20	
070GSCA0125F	Y		125	1900	11800	11.6	21		

Note: Minimum operating voltage for integrated trip indicator = 20V  
 070GSCAxxxxF: DIN80 gR Size 000 with blow fuse trip indicator may be adapted to use Microswitch ref: MS 4L 2-5 B6



**Electrical Characteristics:**

**Times vs Current Characteristics:**

The curve below shows, for each rating, value of peak let-through current  $I_c$  as a function of available fault current  $I_p$ . Tolerance for mean pre-arcing current  $\pm 8\%$ .

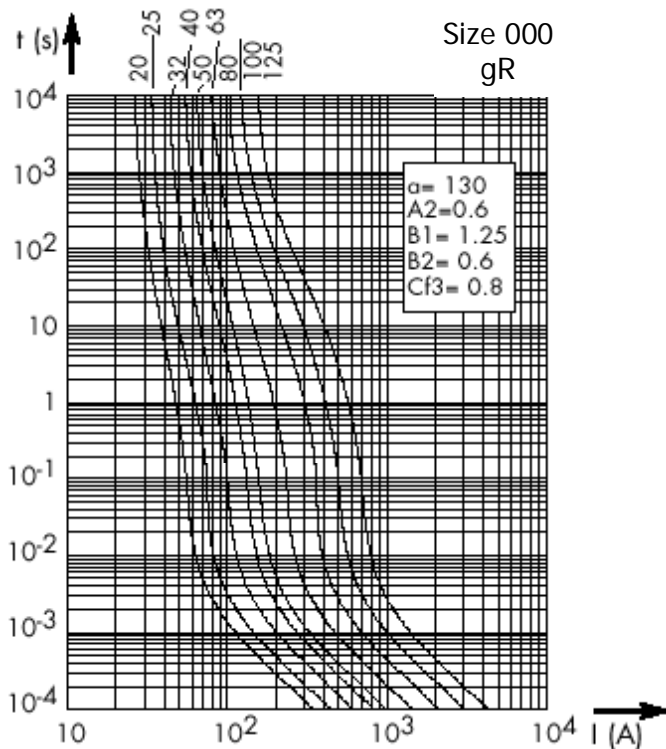

**Total clearing  $I^2t$ :** horizontal curves show, for each rated current, values of total clearing  $I^2t(I^2t_t)$  as a function of prospective current  $I_p @ U_N$  with  $\cos\phi = 0.15$ . Oblique lines indicate total clearing duration  $T_t$ , with associated pre-arcing duration in brackets.

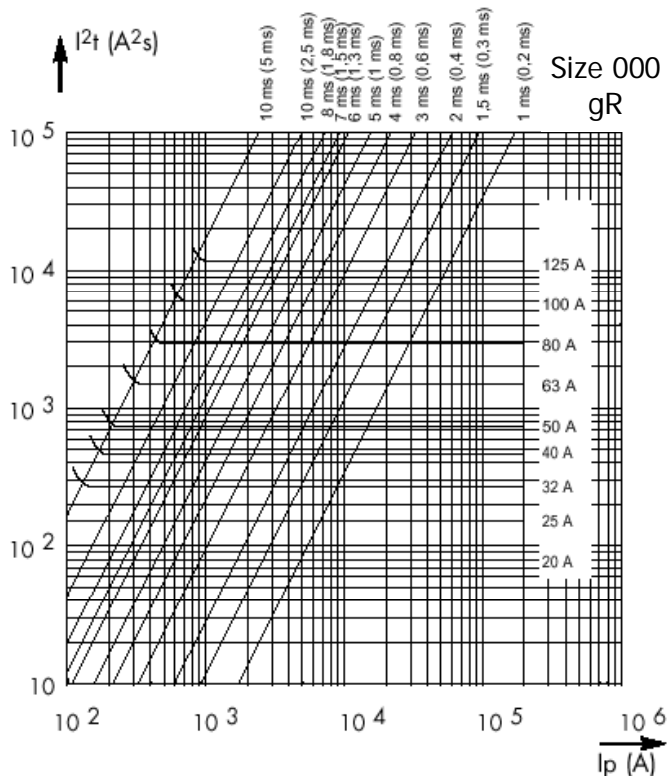

**Current Limitation Curves:**

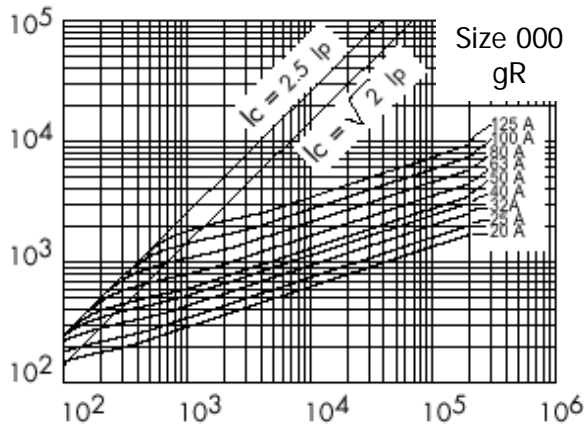

The curve below shows, for each rating, value of peak let-through current  $I_c$  as a function of available fault current  $I_p$ .

**$I^2t$  Corrective Factor:**

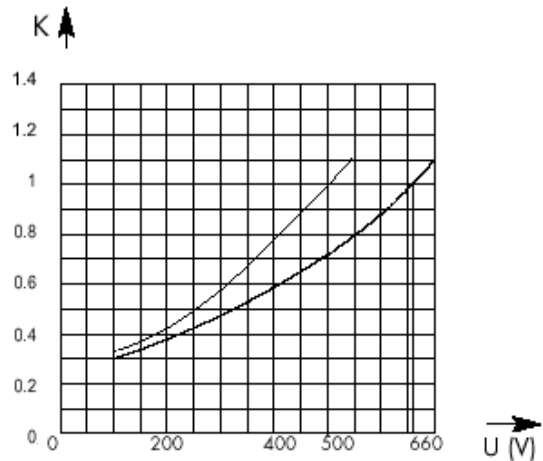

Mean curves show variation of total clearing time ( $I^2t_t$ ) and total clearing duration  $T_t$  as a function of operating voltage  $U$ .

**Peak Arc Voltage:**

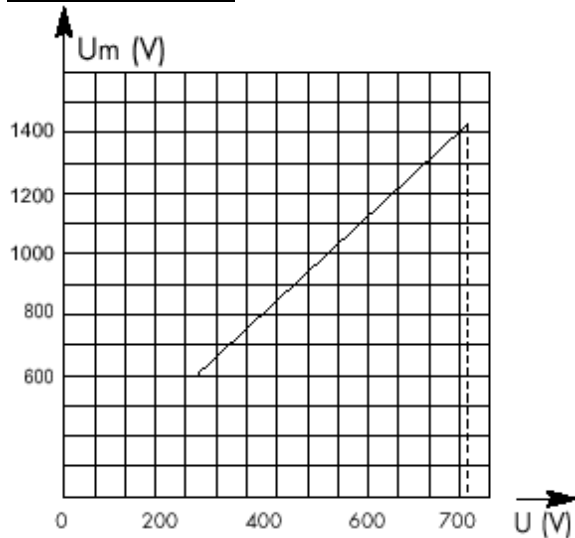

Curve shows peak value  $U_m$  of arc voltage which appears across fuse link as a function of the operating voltage  $U @ \cos \phi = 0.15$

**Power Loss:**

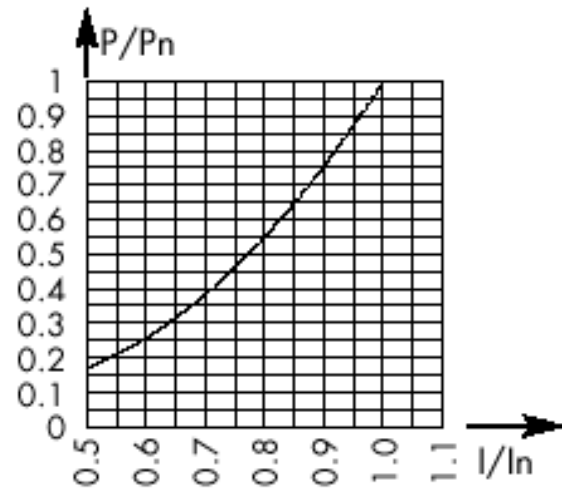

Curve enables computation of power losses  $P$  for a  $I_N$ -rated fuse as a function of RMS current  $I$  (as a multiple of  $I_N$  for steady state operation).

Outline Drawing & Ordering Information

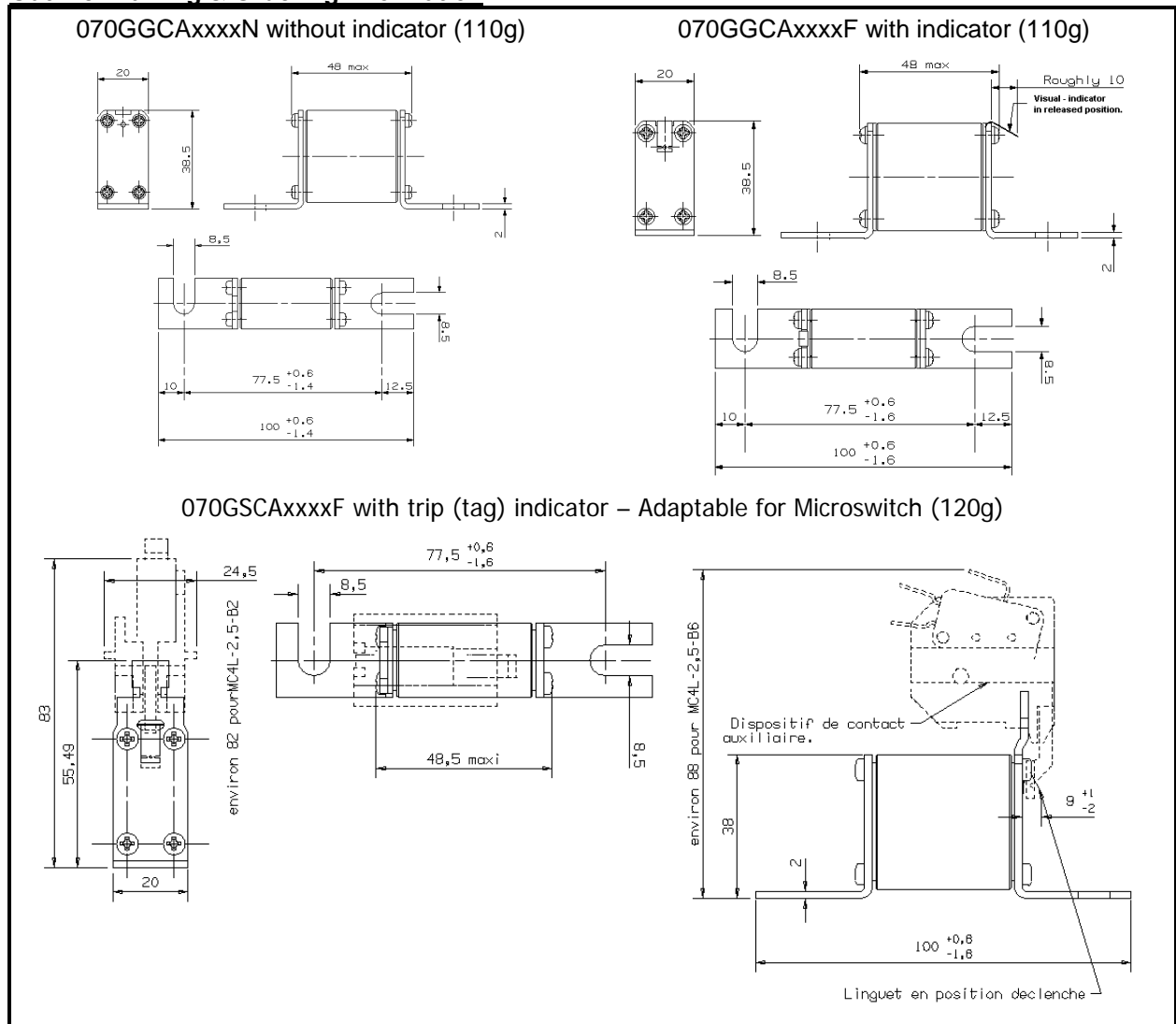

**ORDERING INFORMATION** (Please quote code as below)

Voltage Rating (V)	Type	Size 000	80mm Fixing	Current Rating (A)	Indicator
700	GG / GS	C	A	0020 - 0125	F / N

Order code: e.g. **070GSCA0020F** = 700V, German Standard, size 000, DIN 80, 20A knife blade fuse with trip (tag) indicator.

**IXYS Semiconductor GmbH**  
 Edisonstraße 15  
 D-68623 Lampertheim  
 Tel: +49 6206 503-0  
 Fax: +49 6206 503-627  
 E-mail: [marcom@ixys.de](mailto:marcom@ixys.de)



**Westcode Semiconductors Ltd**  
 Langley Park Way Langley Park  
 Chippenham Wiltshire Sn15 1GE  
 Tel: +44 (0)1249 444524  
 Fax: +44 (0)1249 659448  
 E-mail: [WSL.sales@westcode.com](mailto:WSL.sales@westcode.com)

**IXYS Corporation**  
 3540 Bassett Street  
 Santa Clara CA 95054 USA  
 Tel: +1 (408) 982 0700  
 Fax: +1 (408) 496 0670  
 E-mail: [sales@ixys.com](mailto:sales@ixys.com)

[www.westcode.com](http://www.westcode.com)

[www.ixys.com](http://www.ixys.com)

**Westcode Semiconductors Inc**  
 3270 Cherry Avenue  
 Long Beach CA 90807 USA  
 Tel: +1 (562) 595 6971  
 Fax: +1 (562) 595 8182  
 E-mail: [WSI.sales@westcode.com](mailto:WSI.sales@westcode.com)

The information contained herein is confidential and is protected by Copyright. The information may not be used or disclosed except with the written permission of and in the manner permitted by the proprietors Westcode Semiconductors Ltd.

© Westcode Semiconductors Ltd.

In the interest of product improvement, Westcode reserves the right to change specifications at any time without prior notice.



## Ultra Rapid Semiconductor Protection Fuse

European Square Body Fuses – 690V

**German Standard Knife Blade  
Voltage Ratings from 660 - 690V  
Current Ratings from 16A to 125A  
gRB characteristics  
Sizes; 000 and 00**













### **Key Features:**

- ❖ Extremely high breaking capacity fuses for the protection of power semiconductors as per IEC Standard 60269.1 and 4.
- ❖ 660 - 690V voltage rating complying with IEC 33
- ❖ Non Magnetic construction
- ❖ gR Characteristics with ratings from 16 to 125A in accordance with VDE 636-23
  - Clearing all overloads
  - Improving safety and protection
  - Enabling selective co-ordination with all fuses
- ❖ All models available with or without integrated trip indicator switch











**Main Characteristics:**

**Knife Blade gR Size 000 with indicator**

Size	Voltage Rating U <sub>N</sub> (V)	Ref:	Micro Switch		Current rating I <sub>N</sub> (A)	Pre-arcing I <sup>2</sup> t @ 1 ms I <sup>2</sup> t <sub>p</sub> (A <sup>2</sup> s)	Total Clearing I <sup>2</sup> t @ U <sub>N</sub> I <sup>2</sup> t <sub>t</sub> (A <sup>2</sup> s)	Power Losses		Tested Interrupting rating
								0.8I <sub>N</sub>	I <sub>N</sub>	
000	660V	066NRCK0016F	Y		16	8.2	60	-	5.6	200kA @690V
		066NRCK0020F	Y		20	12	80	3.8	7	
		066NRCK0025F	Y		25	20	150	5	9	
		066NRCK0032F	Y		32	39	270	5.5	10	
		066NRCK0040F	Y		40	70	460	6.6	12	
		066NRCK0050F	Y		50	102	730	7.7	14	
		066NRCK0063F	Y		63	210	1500	8.8	16	
		066NRCK0080F	Y		80	475	2900	9.9	18	
		066NRCK0100F	Y		100	970	6000	11	20	
		066NRCK0125F	Y		125	1900	11800	11.6	21	

Note: Minimum operating voltage for integrated trip indicator = 20V

**Knife Blade gR Size 00 with trip (tag) indicator**

Size	Voltage Rating U <sub>N</sub> (V)	Ref:	Micro Switch		Current rating I <sub>N</sub> (A)	Pre-arcing I <sup>2</sup> t @ 1 ms I <sup>2</sup> t <sub>p</sub> (A <sup>2</sup> s)	Total Clearing I <sup>2</sup> t @ U <sub>N</sub> I <sup>2</sup> t <sub>t</sub> (A <sup>2</sup> s)	Power Losses		Tested Interrupting rating
								0.8I <sub>N</sub>	I <sub>N</sub>	
00	690V	069NRDK0016F	Y		16	8	61	2.7	5	200kA @690V
		069NRDK0020F	Y		20	12	86	3.3	6	
		069NRDK0025F	Y		25	18	140	4.4	8	
		069NRDK0032F	Y		32	39	250	6.0	11	
		069NRDK0040F	Y		40	68	450	7.1	13	
		069NRDK0050F	Y		50	116	750	8.8	16	
		069NRDK0063F	Y		63	210	1400	9.9	18	
		069NRDK0080F	Y		80	525	3000	10.5	19	
		069NRDK0100F	Y		100	970	5400	10.7	19.5	
		069NRDK0125F	Y		125	1710	9600	13.2	24	
		069NRDK0160F	Y		160	4270	22400	13.7	25	

Note: Minimum operating voltage for integrated trip indicator = 20V

Note: 069NRDKxxxxF: DIN80 gR Size 00 with knife blade contact may be adapted for micro switch ref: MS 4L 2-5 B6 

**Electrical Characteristics:**

**Times vs current characteristics:**

The following curves indicate, for each rated current, pre-arcing time as a function of RMS value of pre-arcing current I.

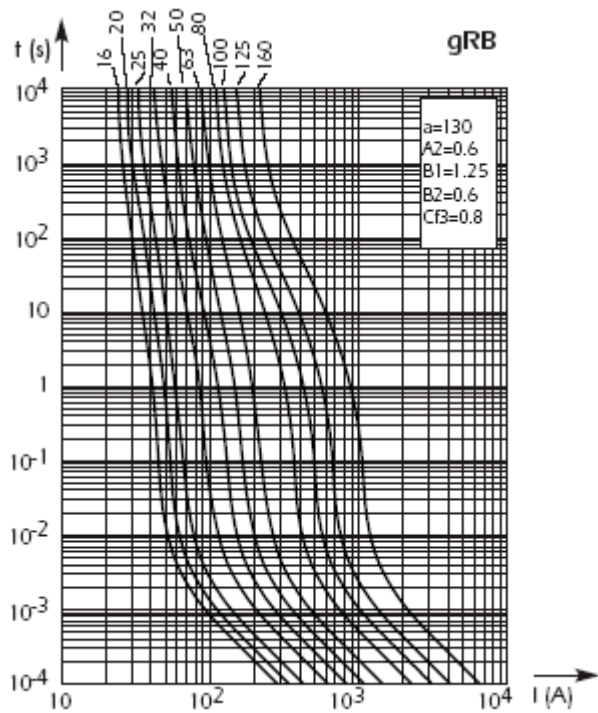

Tolerance for mean pre-arcing current  $\pm 8\%$

**Total clearing I<sup>2</sup>T:**

Horizontal curves show, for each rated current, values of total clearing  $I^2t$  ( $I^2t_i$ ) as a function of prospective current  $I_p @ U_N$  with  $\cos\phi = 0.15$ . Oblique lines indicate total clearing duration  $T_t$ , with associated pre-arcing duration in brackets.

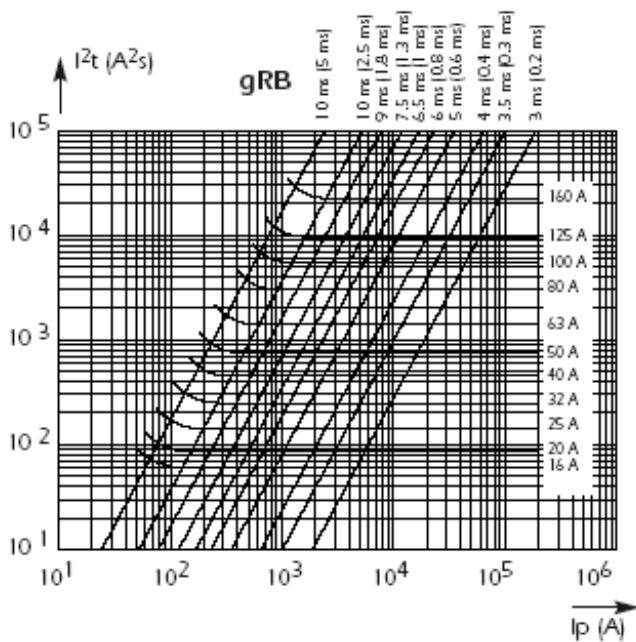

**Cut off Characteristics:**

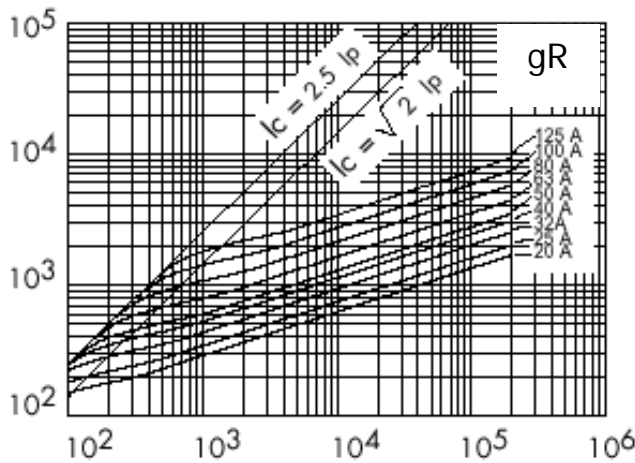

The curve above shows, for each rating, value of peak let-through current  $I_c$  as a function of the available fault current  $I_p$ .

**$I^2t$  Corrective Factor:**

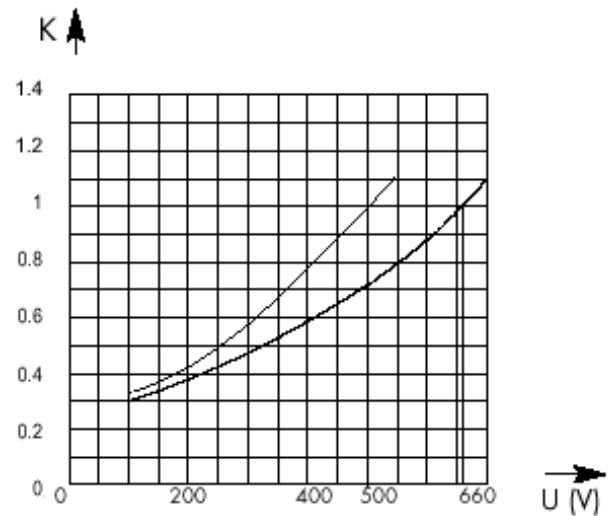

Mean curves showing variation of total clearing time ( $I^2t$ ) and total clearing duration  $Tt$  as a function of operating voltage  $U$ .

**Peak Arc Voltage:**

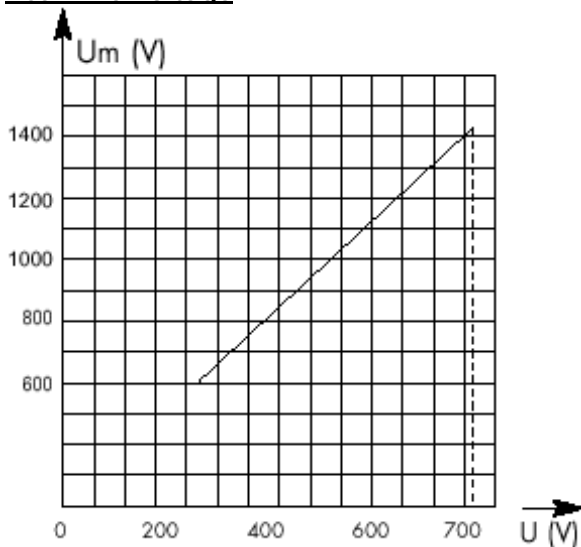

Curves showing peak value  $U_m$  of arc voltage which appears across fuse link as a function of operating voltage  $U$  @  $\cos\phi = 0.15$ .

**Dissipated Power:**

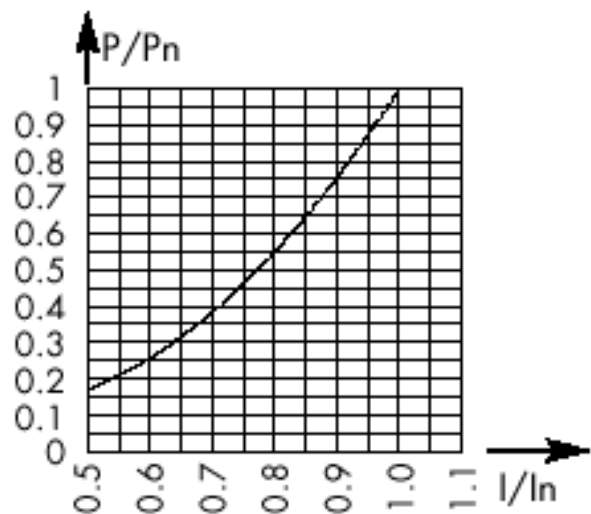

Curve enables computation of power losses  $P$  for a  $I_n$  rated fuse as a function of the RMS current  $I$  (as a multiple of  $I_n$  for steady state operation).

**Outline Drawing & Ordering Information:**

NRCKxxxxF – Size 000 – 150g

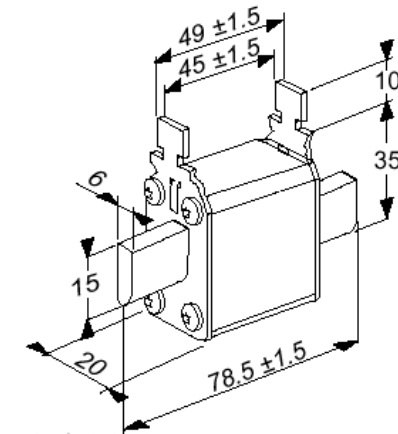

NRDKxxxxF – Size 00 – 210g

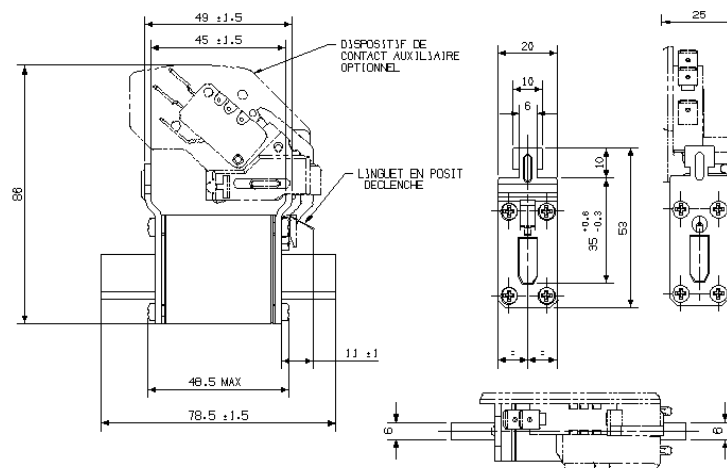

**ORDERING INFORMATION** (Please quote code as below)

Voltage Rating (V)	Type	Size	Fixing	Current Rating (A)	With Indicator
660 or 690	NR	C or D	K	16 - 160	F

**Order code:** e.g. **069NRDK0125F** = 690V German Standard gR , Size 00, Knife Blade, 125A fuse with trip (tag) indicator.

**IXYS Semiconductor GmbH**  
 Edisonstraße 15  
 D-68623 Lampertheim  
 Tel: +49 6206 503-0  
 Fax: +49 6206 503-627  
 E-mail: [marcom@ixys.de](mailto:marcom@ixys.de)



**Westcode Semiconductors Ltd**  
 Langley Park Way Langley Park  
 Chippenham Wiltshire SN15 1GE  
 Tel: +44 (0)1249 444524  
 Fax: +44 (0)1249 659448  
 E-mail: [WSL.sales@westcode.com](mailto:WSL.sales@westcode.com)

**IXYS Corporation**  
 3540 Bassett Street  
 Santa Clara CA 95054 USA  
 Tel: +1 (408) 982 0700  
 Fax: +1 (408) 496 0670  
 E-mail: [sales@ixys.com](mailto:sales@ixys.com)

[www.westcode.com](http://www.westcode.com)

[www.ixys.com](http://www.ixys.com)

**Westcode Semiconductors Inc**  
 3270 Cherry Avenue  
 Long Beach CA 90807 USA  
 Tel: +1 (562) 595 6971  
 Fax: +1 (562) 595 8182  
 E-mail: [WSI.sales@westcode.com](mailto:WSI.sales@westcode.com)

The information contained herein is confidential and is protected by Copyright. The information may not be used or disclosed except with the written permission of and in the manner permitted by the proprietors Westcode Semiconductors Ltd.

© Westcode Semiconductors Ltd.

In the interest of product improvement, Westcode reserves the right to change specifications at any time without prior notice.

## Ultra Rapid Semiconductor Protection Fuse

European Square Body Type

German Standard Knife Blade  
aR Characteristics  
Voltage Rating 690V  
Current Ratings from 16A to 1000A  
Sizes 000, 00, 0, 1, 2 & 3



### **Key Features:**

- ❖ Extremely high interrupting rating fuses for the protection of power semiconductors as per IEC Standard 60269.1 and 4
- ❖ 690V voltage rating complying with IEC 33
- ❖ Non Magnetic construction
- ❖ aR Characteristics (current ratings from 16A to 1000A) as per VDE 636-23 and IEC 269.4
- ❖ All models with double indication visual on the top and integrated trip-indicator
- ❖ Microswitch system reference MS 4L 2-5 B+PRES

**Main Characteristics:**

Size	Voltage $U_N$ (V)	Ref:	Micro Switch	Current rating $I_N$ (A)	Pre-arcing $I^2t @ 1 \text{ ms}$ $I^2t_p$ (A <sup>2</sup> s)	Total Clearing $I^2t @ U_N$ (A <sup>2</sup> s)	Power Losses @ 0.8 $I_N$	Tested Interrupting rating
000	690V	069NHCK0016F	Y	16	10	48	1	80kA @ 690V
		069NHCK0020F	Y	20	15	90	1.5	
		069NHCK0025F	Y	25	22	130	2	
		069NHCK0032F	Y	32	45	270	2.5	
		069NHCK0040F	Y	40	69	400	4	
		069NHCK0050F	Y	50	107	630	5	
		069NHCK0063F	Y	63	220	1300	6	
		069NHCK0080F	Y	80	350	2000	8	
		069NHCK0100F	Y	100	720	4300	9.5	
		069NHCK0125F	Y	125	1400	8200	10.5	
		069NHCK0160F		160	2100	12200	15	
		069NHCK0200F		200	3900	22700	18	
		069NHCK0250F		250	7600	44400	22	
		069NHCK0315F		315	15400	90700	30	

Notes: Minimum operating voltage for integrated trip indicator = 20V

Micro switch reference : MS 4L 2-5B6 

Size	Voltage $U_N$ (V)	Ref:	Micro Switch	Current rating $I_N$ (A)	Pre-arcing $I^2t @ 1 \text{ ms}$ $I^2t_p$ (A <sup>2</sup> s)	Total Clearing $I^2t @ U_N$ (A <sup>2</sup> s)	Power Losses @ 0.8 $I_N$	Tested Interrupting rating
00	690V	069NHDK0020F	Y	20	15	90	1.5	170kA @ 690V
		069NHDK0025F	Y	25	22	130	2	
		069NHDK0032F	Y	32	45	270	2.5	
		069NHDK0040F	Y	40	69	400	4	
		069NHDK0050F	Y	50	110	630	5	
		069NHDK0063F	Y	63	220	1300	6	
		069NHDK0080F	Y	80	350	2000	8	
		069NHDK0100F	Y	100	720	4300	8.5	
		069NHDK0125F	Y	125	1390	8200	10	
		069NHDK0160F	Y	160	2100	12200	14	
		069NHDK0200F	Y	200	3900	22700	17	
		069NHDK0250F	Y	250	7600	44400	20	
		069NHDK0315F	Y	315	15400	90700	29	

Notes: Minimum operating voltage for integrated trip indicator = 20V

Micro switch reference : MS 4L 2-5B6 

Size	Voltage $U_N$ (V)	Ref:	Micro Switch	Current rating $I_N$ (A)	Pre-arcing $I^2t @ 1 \text{ ms}$ $I^2t_p$ (A <sup>2</sup> s)	Total Clearing $I^2t @ U_N$ (A <sup>2</sup> s)	Power Losses @ 0.8 $I_N$	Tested Interrupting rating
0	690V	069NH0K0032F	Y	32	32	170	9.5	170kA @ 690V
		069NH0K0040F	Y	40	53	280	10	
		069NH0K0050F	Y	50	87	470	10.5	
		069NH0K0063F	Y	63	130	700	11.5	
		069NH0K0080F	Y	80	180	970	12.5	
		069NH0K0100F	Y	100	390	2080	15	
		069NH0K0125F	Y	125	720	3890	18	
		069NH0K0160F	Y	160	1550	8320	22	
		069NH0K0200F	Y	200	2950	15900	27	
		069NH0K0250F	Y	250	5560	29900	33	
		069NH0K0315F		315	11600	62300	40	

Notes: Minimum operating voltage for integrated trip indicator = 20V.

Micro switch reference : MS 4L 2-5B6 

Size	Voltage $U_N$ (V)	Ref:	Micro Switch	Current rating $I_N$ (A)	Pre-arcing $I^2t @ 1 \text{ ms}$ $I^2t_p$ (A <sup>2</sup> s)	Total Clearing $I^2t @ U_N$ (A <sup>2</sup> s)	Power Losses @ 0.8 $I_N$	Tested Interrupting rating
1	690V	069NH1K0063F	Y	63	130	700	18	170kA @ 690V
		069NH1K0080F	Y	80	220	1170	21,5	
		069NH1K0100F	Y	100	290	1570	23	
		069NH1K0125F	Y	125	620	3320	26	
		069NH1K0160F	Y	160	1170	6270	29	
		069NH1K0200F	Y	200	2470	13300	33	
		069NH1K0250F	Y	250	4670	25100	37	
		069NH1K0315F	Y	315	9570	51400	42	
		069NH1K0350F	Y	350	13400	72300	44	
		069NH1K0400F	Y	400	19500	105000	48	

Notes: Minimum operating voltage for integrated trip indicator = 20V.

Micro switch reference : MS 4L 2-5B6 



Size	Voltage U <sub>N</sub> (V)	Ref:	Micro Switch	Current rating I <sub>N</sub> (A)	Pre-arcing I <sup>2</sup> t @ 1 ms I <sup>2</sup> t <sub>p</sub> (A <sup>2</sup> s)	Total Clearing I <sup>2</sup> t @ U <sub>N</sub> (A <sup>2</sup> s)	Power Losses @ 0.8 I <sub>N</sub>	Tested Interrupting rating
2	690V	069NH2K0160F	Y	160	960	5180	38	170kA @ 690V
		069NH2K0200F	Y	200	1710	9220	42	
		069NH2K0250F	Y	250	3480	18700	46.5	
		069NH2K0315F	Y	315	6860	36900	54	
		069NH2K0350F	Y	350	9570	51400	58	
		069NH2K0400F	Y	400	13400	72300	62.5	
		069NH2K0450F	Y	450	21000	113000	69	
		069NH2K0500F	Y	500	27400	147000	73	
		069NH2K0550F	Y	560	38300	206000	78	
		069NH2K0630F	Y	630	58700	315000	85	
		069NH2K0700F		700	78100	420000	87	

Notes: Minimum operating voltage for integrated trip indicator = 20V.

Micro switch reference : MS 4L 2-5B6 

Size	Voltage U <sub>N</sub> (V)	Ref:	Micro Switch	Current rating I <sub>N</sub> (A)	Pre-arcing I <sup>2</sup> t @ 1 ms I <sup>2</sup> t <sub>p</sub> (A <sup>2</sup> s)	Total Clearing I <sup>2</sup> t @ U <sub>N</sub> (A <sup>2</sup> s)	Power Losses @ 0.8 I <sub>N</sub>	Tested Interrupting rating
3	690V	069NH3K0315F	Y	315	5251	28200	57	170kA @ 690V
		069NH3K0350F	Y	350	7562	40600	58	
		069NH3K0400F	Y	400	10500	56500	65.5	
		069NH3K0450F	Y	450	15700	84300	70	
		069NH3K0500F	Y	500	22200	119000	75	
		069NH3K0550F	Y	560	30200	163000	80	
		069NH3K0630F	Y	630	42000	226000	89	
		069NH3K0700F	Y	700	61700	332000	100	
		069NH3K0800F	Y	800	88900	478000	112	
		069NH3K0900F	Y	900	123900	666000	125	
		069NH3K1000F		1000	178400	959000	140	

Notes: Minimum operating voltage for integrated trip indicator = 20V.

Micro switch reference : MS 4L 2-5B6 

**Electrical Characteristics:**

**Times vs current characteristics**

The following curves and those on page 6 indicate, for each rated current, pre-arcing time as a function of RMS value of pre-arcing current I.

Tolerance for mean pre-arcing current:

±10% = ratings from (to be confirmed)

± 8% = ratings from (to be confirmed)

They do not show a minimum breaking capacity but limit currents of non-operation or operation in compliance with standard VDE 636/23.

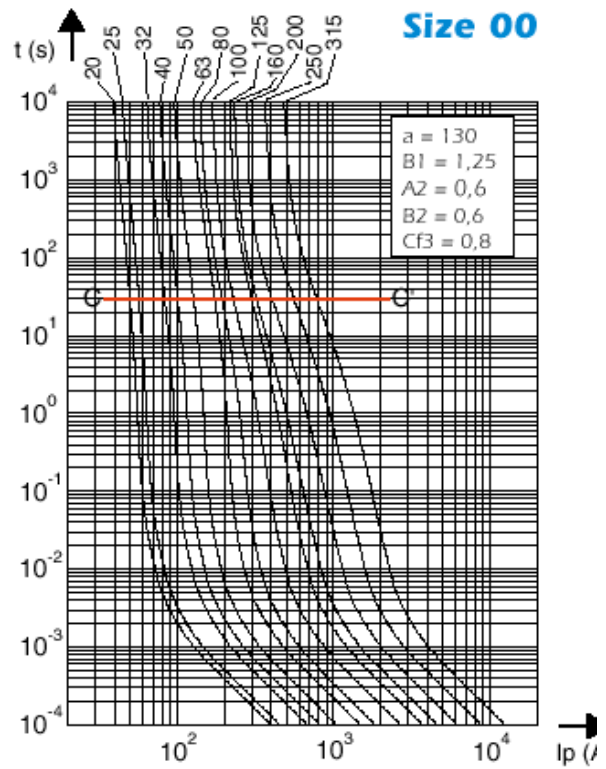
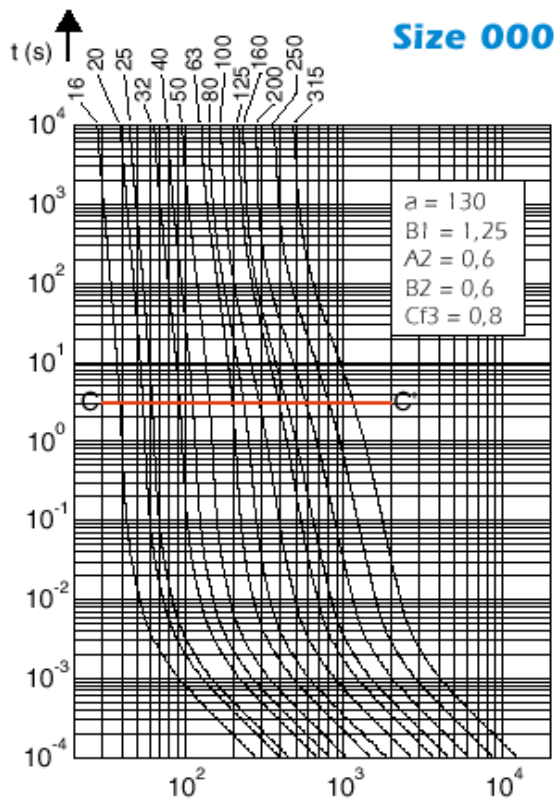

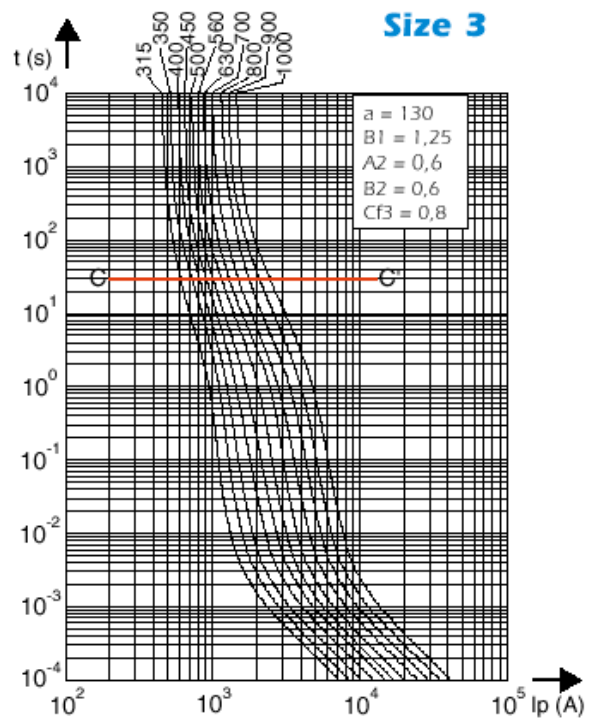
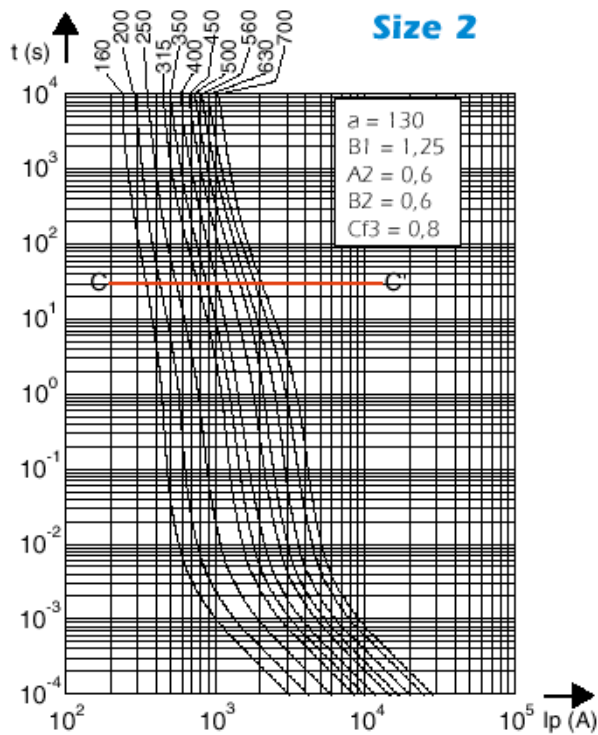
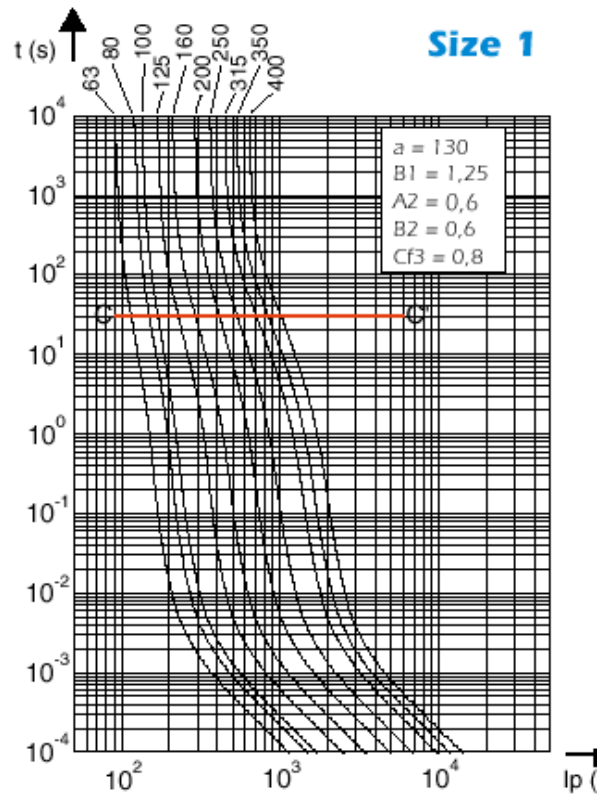
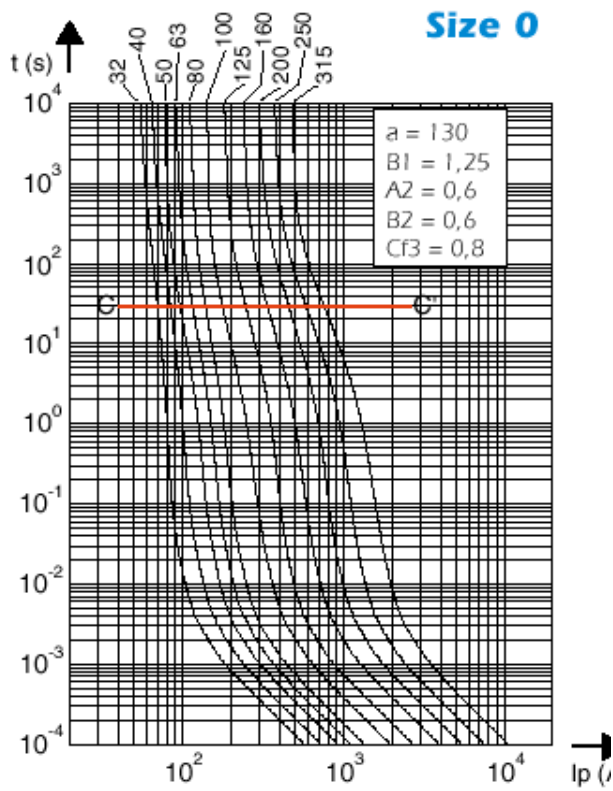

**Total clearing I<sup>2</sup>T:**

Horizontal curve shows maximum values of total clearing I<sup>2</sup>t (I<sup>2</sup>t<sub>t</sub>) for each rated current as a function of prospective current I<sub>p</sub> @ 690V cos φ = 0.15. Oblique lines indicate total clearing duration T<sub>t</sub>, with associated pre-arcing duration in brackets.

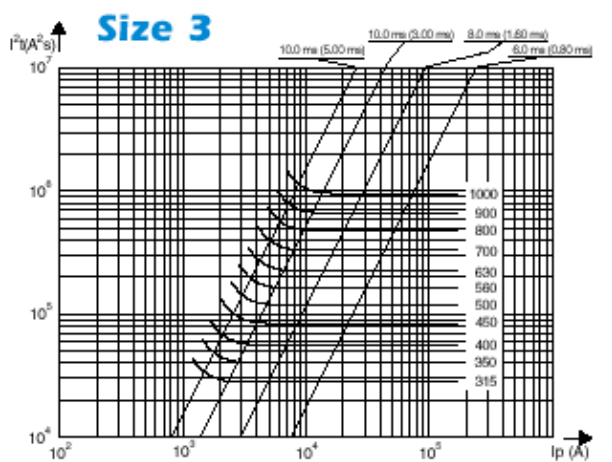
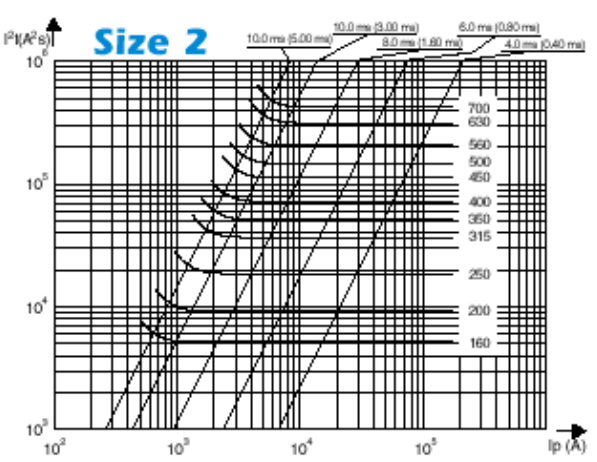
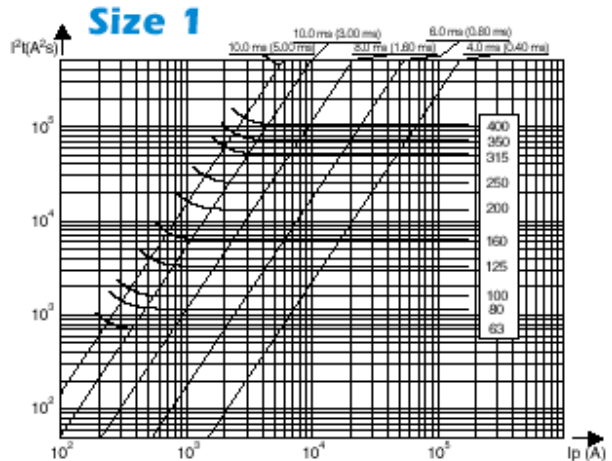
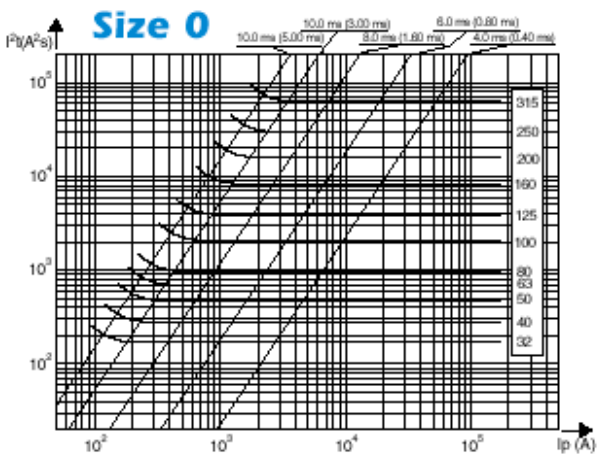
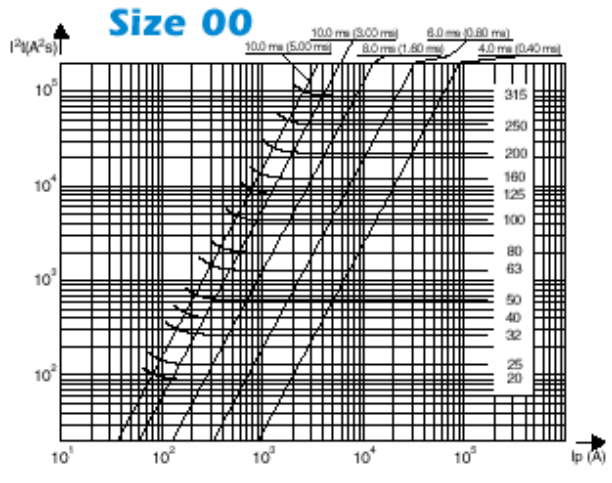
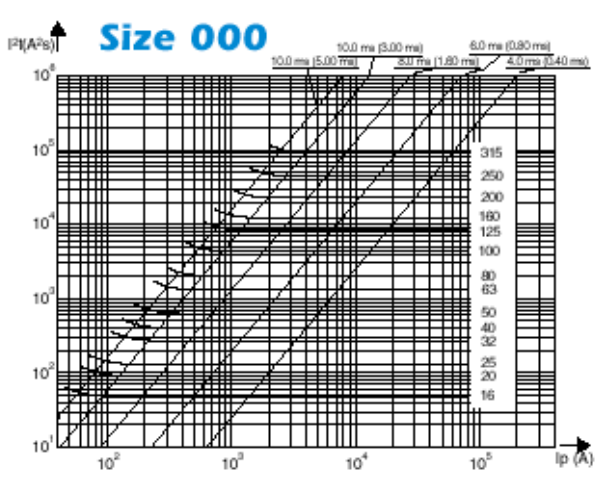

**Cut off Characteristics:**

The curve above shows, for each rating, value of peak let-through current  $I_C$  as a function of available fault current  $I_p$ .

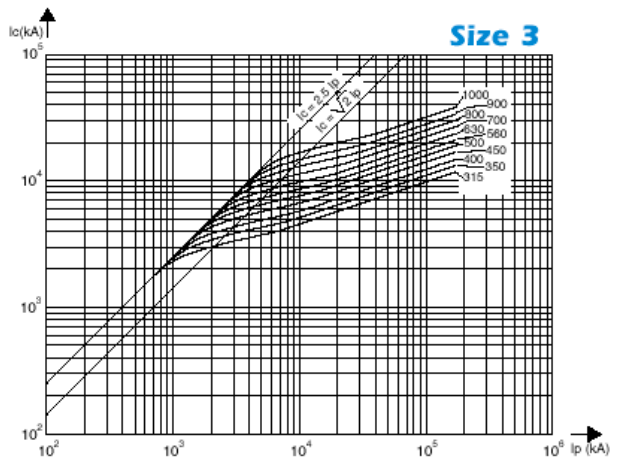
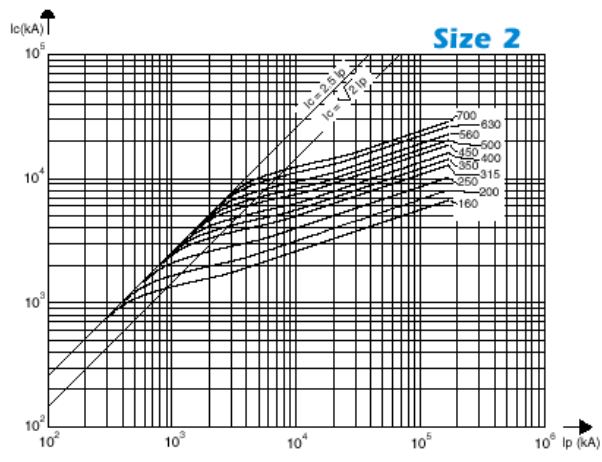
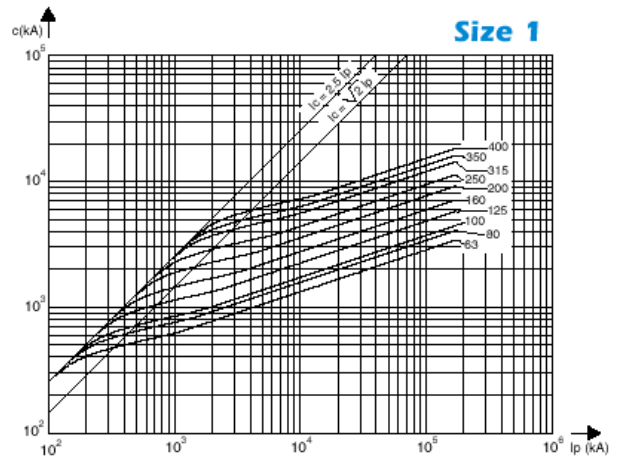
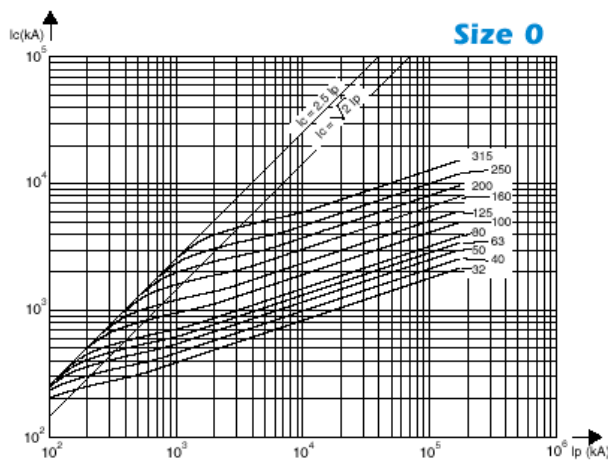
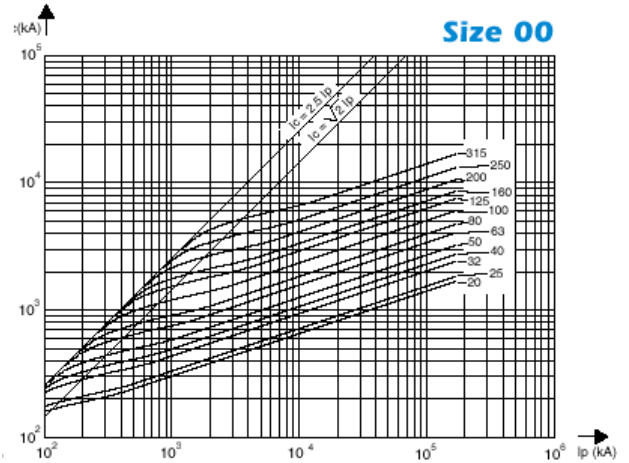
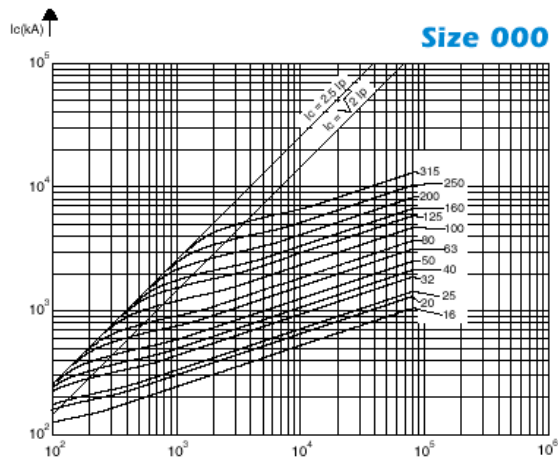

**I<sup>2</sup>t Multiplier Coefficient**

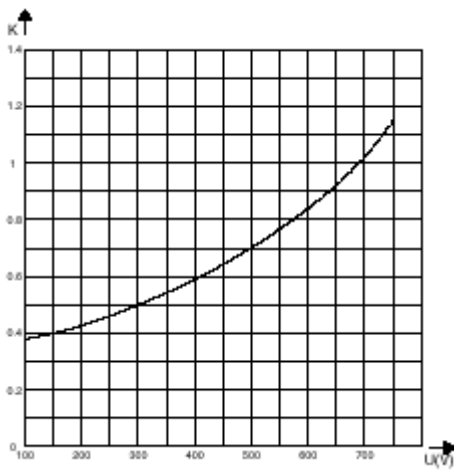

Mean curves showing variation of total clearing time ( $I^2t_t$ ) and total clearing duration  $T_t$  as a function of operating voltage  $U$ .

**Peak arc voltage**

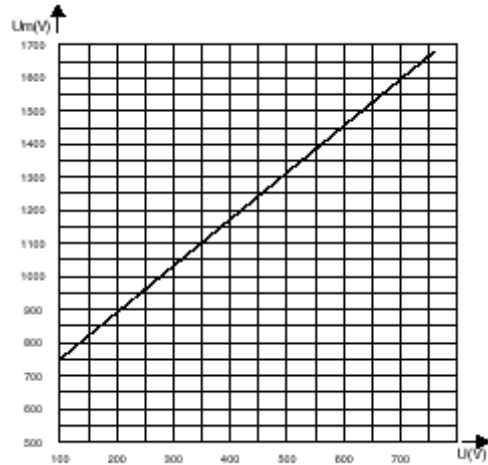

Curves showing peak value  $U_m$  of arc voltage which appears across fuse-link as a function of operating voltage  $U$  @  $\cos\phi = 0.15$

**Dissipated Power**

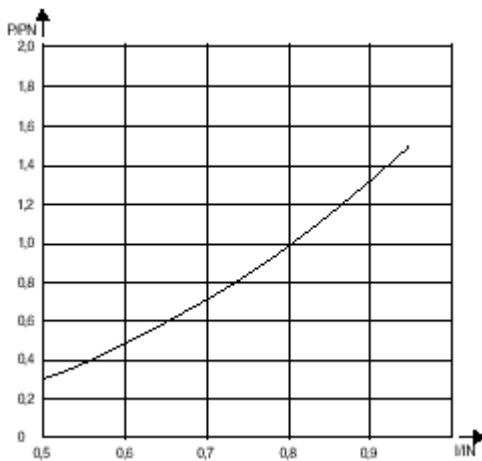

Curve enabling calculation of dissipated power  $P$  by a fuse rated  $I_N$ , as a function of the RMS current  $I$ , in multiples of  $I_N$  in a steady state.

**Outline Drawing & Ordering Information:**

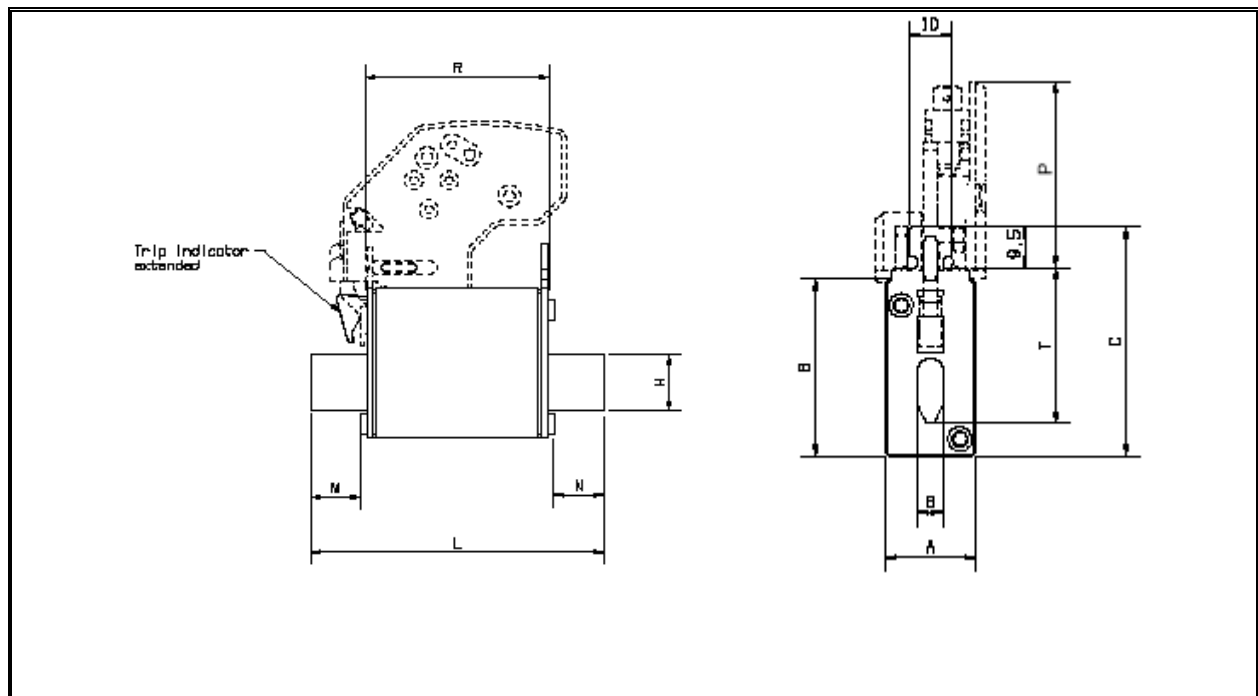

Size	A	B	C	H	L	M	N	P	R	T	Weight
000	20.8	40.5	52.5	15	79	13.5	13.5	43.4	49.5	35	135gm
00	29.5	47.5	59.5	15	79	13.1	13.1	43.4	50	35	200gm
0	29.5	47.5	59.5	15	125	29.1	29.1	43.4	66	35	250gm
1	39.5	52.5	64.5	20	135	32.1	32.1	43.4	68	40	430gm
2	51	60	72	26	150	38.85	38.85	43.4	68	48	600gm
3	70	74	86	33	150	38.85	38.85	43.4	68	60	750gm

**ORDERING INFORMATION**

(Please quote code as below)

Voltage Rating (V)	Type	Size	Fixing	Current Rating (A)	Trip (Tag) Indicator
690	NH	000 "C", 00 "D", 0, 1, 2, 3	K	0016 - 1000	F

Order code: e.g. **069NHCK0200F** = 690V European Square body, size 000, knife blade, 200Amps with flap type indicator.

**IXYS Semiconductor GmbH**  
 Edisonstraße 15  
 D-68623 Lampertheim  
 Tel: +49 6206 503-0  
 Fax: +49 6206 503-627  
 E-mail: [marcom@ixys.de](mailto:marcom@ixys.de)



An IXYS Company

**Westcode Semiconductors Ltd**  
 Langley Park Way Langley Park  
 Chippenham Wiltshire SN15 1GE  
 Tel: +44 (0)1249 444524  
 Fax: +44 (0)1249 659448  
 E-mail: [WSL.sales@westcode.com](mailto:WSL.sales@westcode.com)

**IXYS Corporation**  
 3540 Bassett Street  
 Santa Clara CA 95054 USA  
 Tel: +1 (408) 982 0700  
 Fax: +1 (408) 496 0670  
 E-mail: [sales@ixys.com](mailto:sales@ixys.com)

[www.westcode.com](http://www.westcode.com)

[www.ixys.com](http://www.ixys.com)

**Westcode Semiconductors Inc**  
 3270 Cherry Avenue  
 Long Beach CA 90807 USA  
 Tel: +1 (562) 595 6971  
 Fax: +1 (562) 595 8182  
 E-mail: [WSI.sales@westcode.com](mailto:WSI.sales@westcode.com)

The information contained herein is confidential and is protected by Copyright. The information may not be used or disclosed except with the written permission of and in the manner permitted by the proprietors Westcode Semiconductors Ltd.

© Westcode Semiconductors Ltd.

In the interest of product improvement, Westcode reserves the right to change specifications at any time without prior notice.

## Ultra Rapid Semiconductor Protection Fuse

### Microswitch Systems

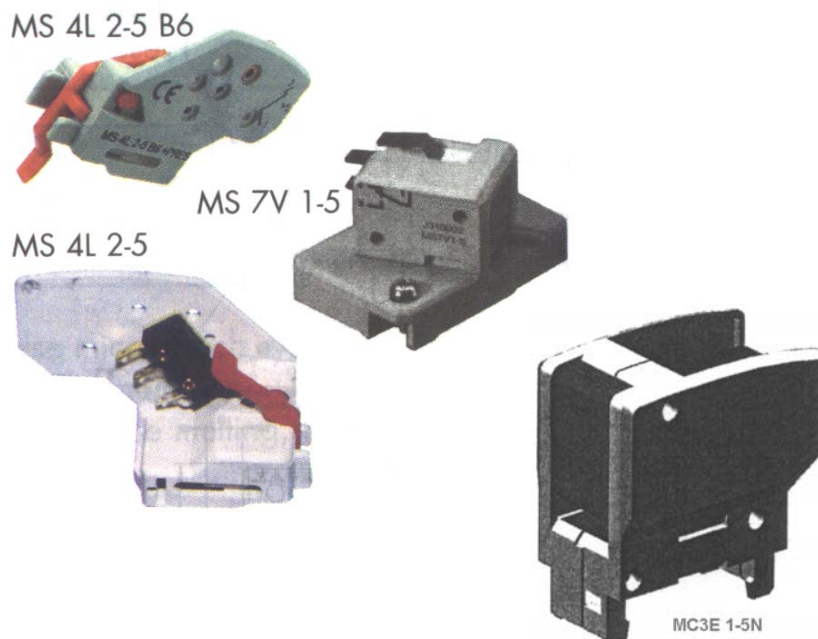

#### **Key Features:**

- ❖ Range of microswitch systems adapted for the following fuses:
  - American Square Body
  - European Square Body
  - BS88 Round Body
  - BS88 Square Body



**Microswitch System;**

**MS 3V 1-5**

**Features;**

Manual resetting, standard and low electrical level with different insulation levels, and BS type for use in corrosive atmospheres

**For square body fuse in sizes;**

0, 1, 2 and 3

**Indication Style;**

MS 3V 1-5 = Standard NO-NC

MS 3V 1-5 BS = Low Level NO-NC

MS 3V 1-5 ET = Low Level NO-NC IP 50 (9)

**Weight in grams;**

34gm

**Packaging Quantity;**

3 pieces

Ref:	AC Insulation Voltage rating (***)	Positive operating voltage / current	Current Rating	Interrupting rating						AC Voltage withstand test (*)	Impulse voltage test Uimp 1.2/50 µs (**)	Fire Class according to UL 94	
				Current	Non inductive circuit			Inductive circuit : L/R = 25ms					
					30V	110V	250V	30V	110V				250V
MS 3V 1-5	1000V	20V / 50mA	10A	50/60 Hz	10A	10A	10A	10A	10A	10A	8.5 kV	14 kV	H.B
				DC	8A	0.4A	0.2A	4A	0.2A	0.1A	12 kV	20 kV	
MS 3V 1-5 BS		10V / 10mA	3A	50/60 Hz	3A	3A	3A	2A	1A	1A	8.5 kV	14 kV	
				DC	3A	0.5A	0.25A	3A	0.2A	0.1A	12 kV	20 kV	
MS 3V 1-5 ET		10V / 10mA	3A	50/60 Hz	3A	3A	3A	2A	1A	1A	8.5 kV	14 kV	
				DC	3A	0.5A	-	2A	0.2A	-	12 kV	20 kV	

**Notes:**

\* Between power circuit and microswitch terminals as per IEC 60 and 694 and NFC 64010 (50/60 Hz 1 min duration in dry air)

\*\* Between power circuit and microswitch terminals Uimp : impulse voltage as per IEC 947-1

\*\*\* Between power circuit and microswitch terminals

Each microswitch weighs less than 100g, therefore no Fume & Smoke grade is required by NF F 16-102 Standard

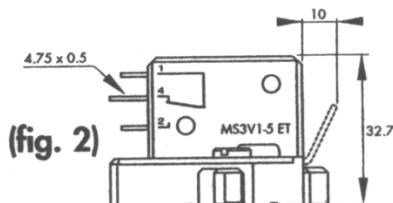
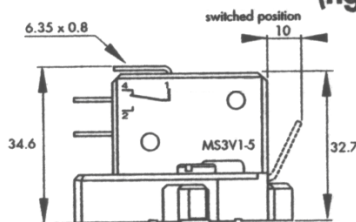
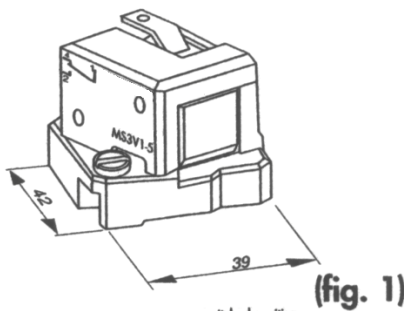

**Microswitch System;**

**MS 7V 1-5**

**Features;**

Manual resetting, standard and low electrical level with different insulation levels, and BS type for use in corrosive atmospheres

**For Square body fuse in sizes;**

0, 1, 2 and 3

**Indication Style;**

MS 7V 1-5 = Standard NO-NC

MS 7V 1-5 BS = Low Level NO-NC

MS 7V 1-5 ET = Low Level NO-NC IP 50 (9)

**Weight in grams;**

45gm, 55gm for MS 7V 1-5 ET

**Packaging Quantity;**

3 pieces

Ref:	AC Insulation Voltage rating (***)	Positive operating voltage / current	Current Rating	Interrupting rating						AC Voltage withstand test (*)	Impulse voltage test Uimp 1.2/50 µs (**)	Fire Class according to UL 94	
				Current	Non inductive circuit			Inductive circuit : L/R = 25ms					
					30V	110V	250V	30V	110V				250V
MS 7V 1-5	1500V	20V / 50mA	10A	50/60 Hz	10A	10A	10A	10A	10A	10A	8.5 kV	14 kV	H.B
				DC	8A	0.4A	0.2A	4A	0.2A	0.1A	12 kV	20 kV	
MS 7V 1-5 BS		10V / 10mA	3A	50/60 Hz	3A	3A	3A	2A	1A	1A	8.5 kV	14 kV	
				DC	3A	0.5A	0.25A	3A	0.2A	0.1A	12 kV	20 kV	
MS 7V 1-5 ET		10V / 10mA	3A	50/60 Hz	3A	3A	3A	2A	1A	1A	8.5 kV	14 kV	
				DC	3A	0.5A	-	2A	0.2A	-	12 kV	20 kV	

**Notes:**

\* Between power circuit and microswitch terminals as per IEC 60 and 694 and NFC 64010 (50/60 Hz 1 min duration in dry air)

\*\* Between power circuit and microswitch terminals Uimp : impulse voltage as per IEC 947-1

\*\*\* Between power circuit and microswitch terminals

Each microswitch weighs less than 100g, therefore no Fume & Smoke grade is required by NF F 16-102 Standard

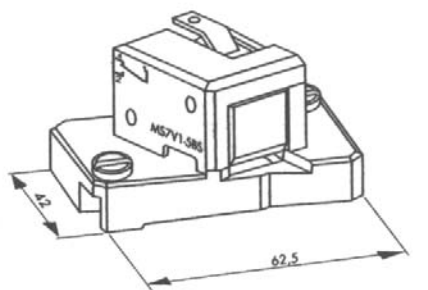

(fig. 5)

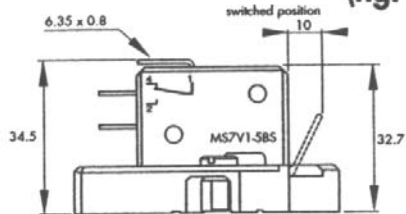

(fig. 6)

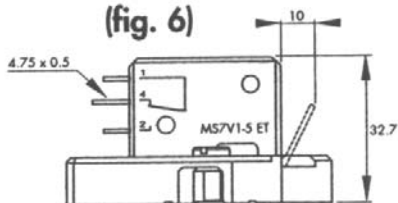



**Microswitch System; MC 6.3 GR 2-5 N**

**Features;** Adapted to meet BS88-4 fuse specifications. Automatically resettable, these microswitch systems indicate fuse presence (PRES) and proper mounting. In the case of improper mounting or fuse melting, this is indicated (terminal 1-4 closed)

**For BS88-4 fuses in sizes;** 0, 1, 2 and 3

**Indication Style;** For BS 88-4 separate blown fuse trip indicators

**Weight in grams;** 10gm

**Packaging Quantity;** 3 pieces

Ref:	AC Insulation Voltage rating (***)	Positive operating voltage / current	Current Rating	Interrupting rating						AC Voltage withstand test (*)	Impulse voltage test Uimp 1.2/50 µs (**)	Fire Class according to UL 94	
				Current	Non inductive circuit			Inductive circuit : L/R = 25ms					
					30V	110V	250V	30V	110V				250V
MC 6.3 GR 2-5 N	1000V	20V / 100mA	5A	50/60 Hz		5A	3A		0.3A	2A	3.5 kV		H.B
				DC	4A	0.4A		3A	0.4A				

**Notes:**

\* Between power circuit and microswitch terminals as per IEC 60 and 694 (50/60 Hz 1 min duration in dry air)

\*\* Between power circuit and microswitch terminals Uimp : impulse voltage as per IEC 947-1

\*\*\* Between power circuit and microswitch terminals

Each microswitch weighs less than 10g, therefore no Fume & Smoke grade is required by NF F 16-102 Standard

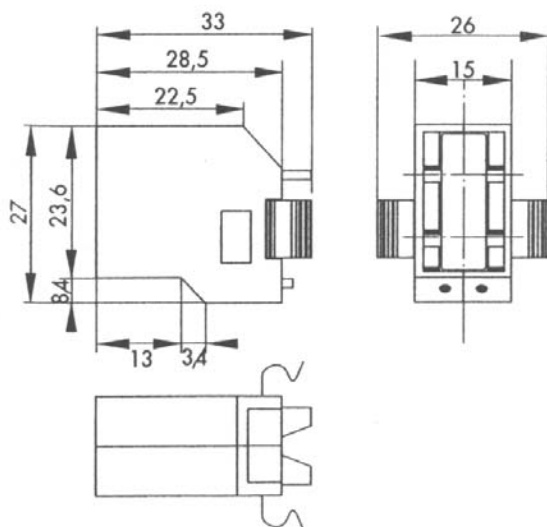
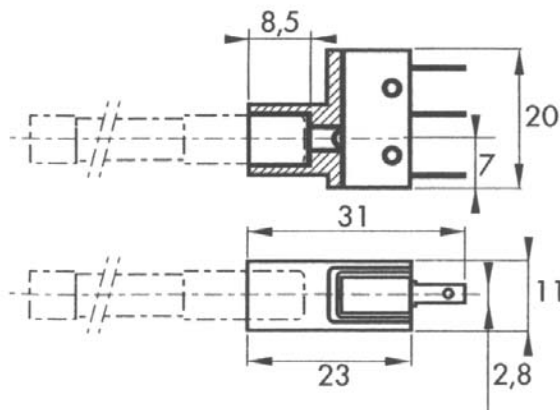

**Microswitch System;** MC3E 1-5N

**Features;** Remote signally system for fitting fuses equipped with microswitch support, with manual resetting, and standard electrical levels.

Also vapour and watertight models available – details upon request.

**For large rectifier fuse sizes;** 0, 1, 2 and 3

**Indication Style;** MC3E 1-5N is a single pole microswitch with permanent indication of fuse state; conductive, blown.

**Weight in grams;** 39.5gm

**Packaging Quantity;** 3 pieces

Ref:	AC Insulation Voltage rating (***)	Positive operating voltage / current	Current Rating	Interrupting rating						AC Voltage withstand test (*)	Impulse voltage test Uimp 1.2/50 µs (**)	Fire Class according to UL 94	
				Current	Non inductive circuit			Inductive circuit : L/R = 25ms					
					30V	110V	250V	30V	110V				250V
MC3E 1-5N	1250	20V / 50mA	5A	50/60 Hz	10A	10A	7A			6A	15 kV	20 kV	H.B
				DC	5A	0.5A			1.6A	0.3A			

**Notes:**

\* Between power circuit and microswitch terminals as per IEC 60 and 694 and NFC 64010 (50/60 Hz 1 min duration in dry air)

\*\* Between power circuit and microswitch terminals Uimp : impulse voltage as per IEC 947-1

\*\*\* Between power circuit and microswitch terminals

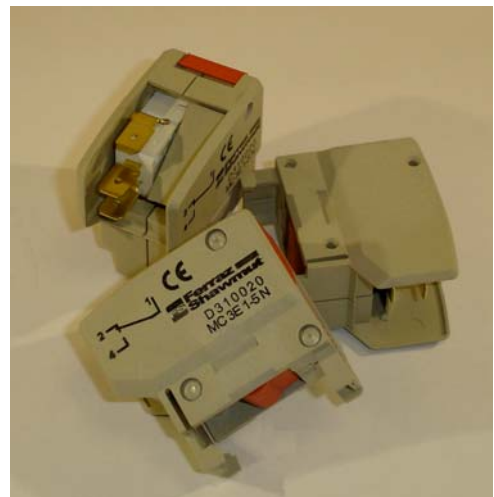
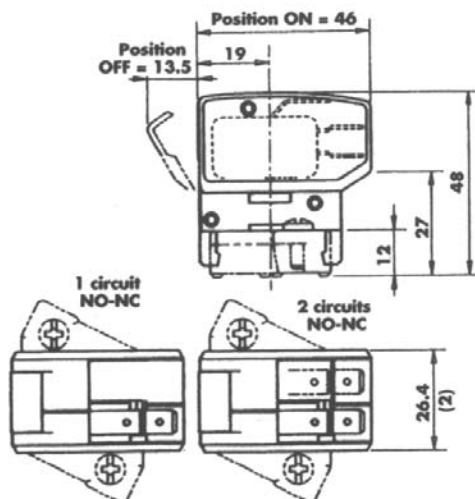

**IXYS Semiconductor GmbH**  
 Edisonstraße 15  
 D-68623 Lampertheim  
 Tel: +49 6206 503-0  
 Fax: +49 6206 503-627  
 E-mail: [marcom@ixys.de](mailto:marcom@ixys.de)

**WESTCODE**  
 An IXYS Company

**Westcode Semiconductors Ltd**  
 Langley Park Way, Chippenham  
 Wiltshire SN15 1GE UK  
 Tel: +44 (0)1249 444524  
 Fax: +44 (0)1249 659448  
 E-mail: [WSL.sales@westcode.com](mailto:WSL.sales@westcode.com)

**IXYS Corporation**  
 3540 Bassett Street  
 Santa Clara CA 95054 USA  
 Tel: +1 (408) 982 0700  
 Fax: +1 (408) 496 0670  
 E-mail: [sales@ixys.com](mailto:sales@ixys.com)

[www.westcode.com](http://www.westcode.com)

[www.ixys.com](http://www.ixys.com)

**Westcode Semiconductors Inc**  
 3270 Cherry Avenue  
 Long Beach CA 90807 USA  
 Tel: +1 (562) 595 6971  
 Fax: +1 (562) 595 8182  
 E-mail: [WSI.sales@westcode.com](mailto:WSI.sales@westcode.com)

The information contained herein is confidential and is protected by Copyright. The information may not be used or disclosed except with the written permission of and in the manner permitted by the proprietors Westcode Semiconductors Ltd.

© Westcode Semiconductors Ltd.

In the interest of product improvement, Westcode reserves the right to change specifications at any time without prior notice.

## Ultra Rapid Semiconductor Protection Fuse Square Body Fuse Bases Fuse holders



SI 000

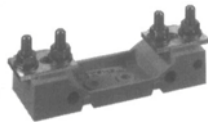

SI 00



SI DIN 80 and 110

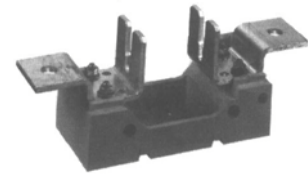

SI TT

### Key Features:

- ❖ Mounting in one pole fuse holder simplifies fuse replacement for installations connected with cables and bars
- ❖ For TTF stud type fuses
- ❖ For blade and bracket type fuses in accordance with DIN 43653 standard
  - Sizes 000 and 00 with 80mm between axes
  - Sizes 0, 1, 2, and 3 with 80mm or 110mm between axes
- ❖ For TTF versions, studs are delivered with the fuse holder
- ❖ Finger safe version also available upon request

**Main Characteristics:**

Part Number	Size	Insulation voltage $U_i$ (AC 50/60 Hz & DC) (V)	Current (A)	Maximum power* (W)	Dielectric Withstand Test		Fire and Fume Classifications
					RMS Voltage 1 mn 50/60 Hz	Impulse Voltage 1.2/50 $\mu$ s	
SI 000 DIN 80	000	700	400	24	7 kV	8 kV	UL 94 VO
SI 00 DIN 80	00	700	400	28	8 kV	12 kV	UL 94 VO : I <sub>3</sub> F <sub>3</sub> (NF 16102)
SI DIN 80 630A	80mm	1500	2500	95	10 kV	12 kV	UL 94 VO : I <sub>1</sub> F <sub>1</sub> (NF 16102)
SI DIN 80 1250A	80mm	1500	2500	110	10 kV	12 kV	
SI DIN110 630A	110mm	1500	2500	95	10 kV	12 kV	
SI DIN110 1250A	110mm	1500	2500	110	10 kV	12 kV	
SI TT 30/31	0/1	1500	1000	53-75	10 kV	12 kV	
SI TT 70/71	0/1	1500	1000	53-75	10 kV	12 kV	UL 94 VO : I <sub>1</sub> F <sub>1</sub> (NF 16102)
SI TT 32/33	2/3	1500	2500	100	10 kV	12 kV	
SI TT 72/73	2/3	1500	2500	100	10 kV	12 kV	

**Vibration Withstand:**

Tests with sine vibrations carried out at ambient with scanning each of the three axes of the holder.

- Spectrum: 1<sup>st</sup> segment (2 to 16Hz) constant trip  $x = 5$  mm peak.  
2<sup>nd</sup> segment (16 to 250Hz) constant acceleration  $\gamma = 5$  g peak.
- Exponential scanning speed: 1 octave per minute.
- Duration: 2 hours per axis

**Outline Drawings & Ordering Information:**

	a	e1	b	c	Size
	SI DIN 80 630	40	5	68	93.5 99.0 103.5 110.3
SI DIN 110 630	40	5	68	93.5 99.0 103.5 110.3	0 1 2 3
SI DIN 80 1250	45	10	73	98.5 104.0 108.5 115.3	0 1 2 3
SI DIN 110 1250	45	10	73	98.5 104.0 108.5 115.3	0 1 2 3

Partition mounting not possible.

