

TOSHIBA IGBT Module Silicon N Channel IGBT

MG200Q2YS65H

High Power & High Speed Switching Applications

Unit: mm

- High input impedance
- Enhancement-mode
- The electrodes are isolated from case.

Equivalent Circuit

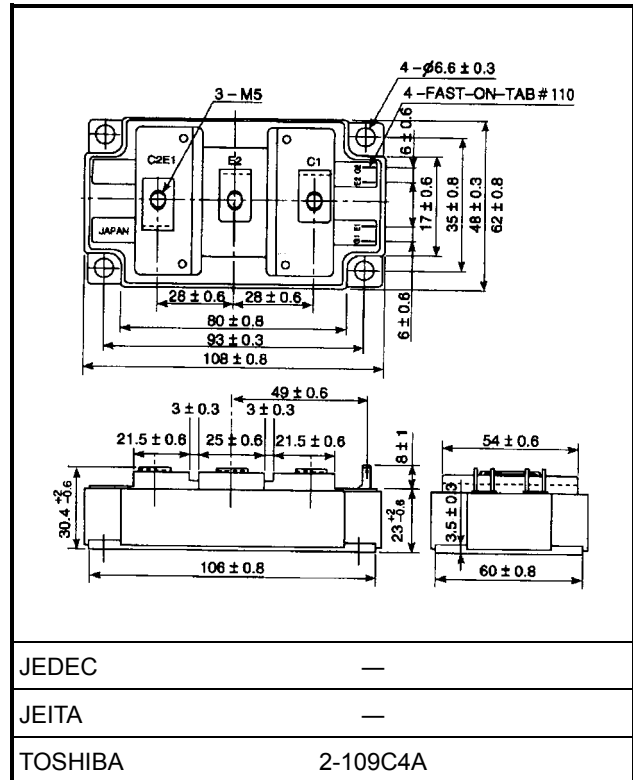
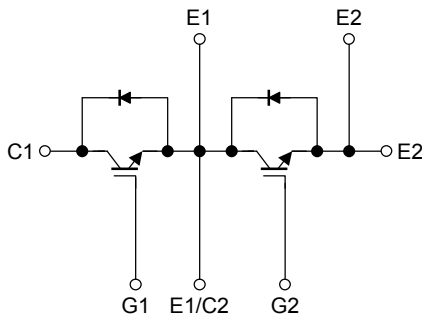

Weight: 430 g (typ.)

Maximum Ratings (Tc = 25°C)

Characteristics	Symbol	Rating	Unit
Collector-emitter voltage	V _{CES}	1200	V
Gate-emitter voltage	V _{GES}	±20	V
Collector current	DC	I _C	200
	1 ms	I _{CP}	400
Forward current	DC	I _F	200
	1 ms	I _{FM}	400
Collector power dissipation (T _c = 25°C)	P _C	1310	W
Junction temperature	T _j	150	°C
Storage temperature range	T _{stg}	-40 to 125	°C
Isolation voltage	V _{Isol}	2500 (AC 1 minute)	V
Screw torque	Terminal	—	3
	Mounting	—	3

Electrical Characteristics (Ta = 25°C)

Characteristics		Symbol	Test Condition	Min	Typ.	Max	Unit	
Gate leakage current		I_{GES}	$V_{GE} = \pm 20 \text{ V}, V_{CE} = 0$	—	—	± 500	nA	
Collector cut-off current		I_{CES}	$V_{CE} = 1200 \text{ V}, V_{GE} = 0$	—	—	2.0	mA	
Gate-emitter cut-off voltage		$V_{GE (off)}$	$I_C = 200 \text{ mA}, V_{CE} = 5 \text{ V}$	4.0	—	7.0	V	
Collector-emitter saturation voltage		$V_{CE (sat)}$	$I_C = 200 \text{ A}, V_{GE} = 15 \text{ V}$	$T_C = 25^\circ\text{C}$	—	3.0	4.0	V
				$T_C = 125^\circ\text{C}$	—	3.6	—	
Input capacitance		C_{ies}	$V_{CE} = 10 \text{ V}, V_{GE} = 0, f = 1 \text{ MHz}$	—	17000	—	pF	
Switching time	Turn-on delay time	$t_{d (on)}$	Inductive load $V_{CC} = 600 \text{ V}, I_C = 200 \text{ A}$ $V_{GE} = \pm 15 \text{ V}, R_G = 4.7 \Omega$	—	0.05	—	μs	
	Rise time	t_r		—	0.05	—		
	Turn-on time	t_{on}		—	0.10	—		
	Turn-off delay time	$t_{d (off)}$		—	0.55	—		
	Fall time	t_f		—	0.05	0.15		
	Turn-off time	t_{off}		—	0.60	—		
Forward voltage		V_F	$I_F = 200 \text{ A}, V_{GE} = 0$	—	2.4	3.5	V	
Reverse recovery time		t_{rr}	$I_F = 200 \text{ A}, V_{GE} = -10 \text{ V}, di/dt = 700 \text{ A}/\mu\text{s}$	—	0.1	—	μs	
Thermal resistance		$R_{th (j-c)}$	Transistor stage	—	—	0.095	$^\circ\text{C}/\text{W}$	
			Diode stage	—	—	0.21		
Switching loss	Turn-on	E_{on}	Inductive load $V_{CC} = 600 \text{ V}, I_C = 200 \text{ A}$ $V_{GE} = \pm 15 \text{ V}, R_G = 4.7 \Omega$ $T_C = 125^\circ\text{C}$	—	20	—	mJ	
	Turn-off	E_{off}		—	17	—		

Note: Switching time measurement circuit and input/output waveforms

