

Protistor® Square-body Fuses PSC aR sizes 3x - 450V to 700 VAC Main characteristics

450 TO 700VAC / 63 TO 2800A

 Recognized

- Exceptionally low I^2t , Watt losses.
- Non-magnetic construction,
- Highly reliable low voltage
- Trip-indicator system, conformity to UL, IEC, DIN and VDE standards.
- Increased technical performance
 - Higher ratings
 - Reduction in volume and weight



This fuse preselection table indicates, for each size:

- rated current (or rating) I_n
- pre-arcing I^2t (I^2t_p) at 1 ms
- total operating I^2t (I^2t_t) at 660 V, $f=50\text{Hz}$ $\cos \varphi=0.15$, and for a total operating time from 8 to 10 ms
- dissipated power P_n at the rated current I_n , and at $0.8 I_n$, in steady state
- breaking capacity at various voltages, checked by tests made in accordance with IEC and American standards.

Semiconductor (AC) fuses



Protistor® Square-body Fuses PSC aR sizes 3x - 450V to 700 VAC Main characteristics

Estimated breaking capacity: 300kA

Size	Nominal Voltage (VAC)		Ampere Rating (A)	Pre-arcing I ² t @ 1ms (kA ² s)	Total I ² t @ 660V (*) @ Un (kA ² s)	Power Pn (W)		Tested Breaking capacity (kA)	
	IEC	USA				End contact	Blades	IEC @ 690V (*) @ Un	USA @ 700V (*) @ Un
30	690	700	50	0,116	0,62	9	9	200	200
			63	0,2	1,1	14	14		
			80	0,33	1,8	19	19		
			100	0,47	2,5	26	26		
			125	0,85	4,5	30	30		
			160	1,6	8,5	37	37		
			200	3	15,5	42	43		
			250	5,8	30	48	50		
			315	12	62	53	55		
			350	15,5	80	57	60		
			400	23	120	60	65		
			450	26	150	80	88		
			500	41	240	80	88		
			550	52	300	80	90		
31	690	700	630	84	450(*)	85	95	200	200
			160	1,3	7	35	35		
			200	2,6	13,5	45	45		
			250	4,7	25	52	52		
			315	7,5	40	65	65		
			350	10,5	55	67	67		
			400	19	100	68	68		
			450	26,5	140	70	70		
			500	37	195	70	72		
			550	52	280	70	75		
			630	75	390	75	85		
			700	95	490	85	95		
			800	140	800	105	120		
			315	5,2	28,9	71	71		
350	8,9	48,8	71	74					
400	15	80	72	75					
450	22	115	77	80					
500	28	145	85	90					
550	37	195	90	95					
630	54	280	95	105					
700	76	400	100	110					
800	115	600	110	120					
900	170	900	110	125					
1000	240	1250	115	135					
1100	270	1450(*)	140	165					
1250	410	1950(*)	150	180					
1400	555	2300(*)	160	200					
1600	870	3600(*)	165	205					
1800	1050	3700(*)	195	230					
32	690	700	450	13,45	74,1	84	88	200	200
			500	19	100	105	105		
			550	27	140	105	110		
			630	40	210	110	120		
			700	55	300	115	125		
			800	95	490	120	130		
			900	135	700	120	135		
			1000	170	900	135	155		
			1100	240	1260	135	160		
			1250	350	1850	150	180		
			1400	480	2500	160	200		
			1500	500	2500(*)	210	240		
			1600	555	2900(*)	210	240		
			1800	720	3870(*)	225	260		
2000	950	4500(*)	250	290					
2250	1250	5160(*)	280	320					
2500	1870	6540(*)	280	330					
33	690	700	800	60	320	144	144	200	200
			1000	110	590	165	165		
			1250	220	1100	190	190		
			1400	300	1600	200	200		
			1600	450	2400	220	220		
			1800	700	3500	225	225		
			2000	950	5000	235	235		
			2200	1100	5250(*)	280	280		
			1000	76	395	220	220		
			1250	160	850	230	230		
			1400	225	1200	240	240		
			1600	375	1900	250	250		
			1800	530	2800	250	250		
			2000	700	3100(*)	280	280		
2200	950	4400(*)	280	280					
2500	1400	6600(*)	310	310					
2800	1900	8800(*)	330	330					
2X32	690	700	800	60	320	144	144	200	200
			1000	110	590	165	165		
			1250	220	1100	190	190		
			1400	300	1600	200	200		
			1600	450	2400	220	220		
			1800	700	3500	225	225		
2x33	690	700	2000	950	5000	235	235	170	170
			2200	1100	5250(*)	280	280		
			1000	76	395	220	220		
			1250	160	850	230	230		
			1400	225	1200	240	240		
			1600	375	1900	250	250		
2x33	600	650	2000	700	3100(*)	280	280	160(*)	160(*)
			2200	950	4400(*)	280	280		
			2500	1400	6600(*)	310	310		
			2800	1900	8800(*)	330	330		

For others Ampere ratings consult us
12/04

Protistor® Square-body Fuses PSC aR sizes 3x - 450V to 700 VAC American Terminals - 30 - 33 End contacts



Size	Designation			Reference Number	Weight (g)	Packaging	Catalog Number
30	A070 URD	30	TTI 0050	V302744	245	3	A070UD30TTI 50
	A070 URD	30	TTI 0063	A301967			A070UD30TTI 63
	A070 URD	30	TTI 0080	V301962			A070UD30TTI 80
	A070 URD	30	TTI 0100	W300744			A070UD30TTI100
	A070 URD	30	TTI 0125	G300708			A070UD30TTI125
	A070 URD	30	TTI 0160	N300576			A070UD30TTI160
	A070 URD	30	TTI 0200	P300577			A070UD30TTI200
	A070 URD	30	TTI 0250	Q300578			A070UD30TTI250
	A070 URD	30	TTI 0315	R300579			A070UD30TTI315
	A070 URD	30	TTI 0350	S300580			A070UD30TTI350
	A070 URD	30	TTI 0400	T300581			A070UD30TTI400
	A070 URD	30	TTI 0450	V300582			A070UD30TTI450
	A070 URD	30	TTI 0500	W300583			A070UD30TTI500
	A070 URD	30	TTI 0550	X300584			A070UD30TTI550
	A065 URD	30	TTI 0630	A302703			A065UD30TTI630
31	A070 URD	31	TTI 0160	-	370	3	A070UD31TTI200
	A070 URD	31	TTI 0200	A300472			A070UD31TTI250
	A070 URD	31	TTI 0250	B300473			A070UD31TTI315
	A070 URD	31	TTI 0315	C300474			A070UD31TTI350
	A070 URD	31	TTI 0350	D300475			A070UD31TTI400
	A070 URD	31	TTI 0400	E300476			A070UD31TTI450
	A070 URD	31	TTI 0450	F300477			A070UD31TTI500
	A070 URD	31	TTI 0500	G300478			A070UD31TTI550
	A070 URD	31	TTI 0550	H300479			A070UD31TTI630
	A070 URD	31	TTI 0630	J300480			A070UD31TTI700
	A070 URD	31	TTI 0700	K300481			A070UD31TTI800
A070 URD	31	TTI 0800	L300482				
32	A070 URD	32	TTI 0315	-	510	3	A070UD32TTI400
	A070 URD	32	TTI 0350	-			A070UD32TTI450
	A070 URD	32	TTI 0400	Q300463			A070UD32TTI500
	A070 URD	32	TTI 0450	N300461			A070UD32TTI550
	A070 URD	32	TTI 0500	P300462			A070UD32TTI630
	A070 URD	32	TTI 0550	R300464			A070UD32TTI700
	A070 URD	32	TTI 0630	S300465			A070UD32TTI800
	A070 URD	32	TTI 0700	T300466			A070UD32TTI900
	A070 URD	32	TTI 0800	V300467			A070UD32TTI1000
	A070 URD	32	TTI 0900**	W300468			A065UD32TTI100
	A070 URD	32	TTI 1000**	X300469			A060UD32TTI1250
	A065 URD	32	TTI 1100**	M301081			A055UD32TTI1400
	A060 URD	32	TTI 1250**	N301082			A055UD32TTI1600
	A055 URD	32	TTI 1400**	P301083			A050UD32TTI1800
A055 URD	32	TTI 1600**	Q301084				
A050 URD	32	TTI 1800**	R301085				
33	A070 URD	33	TTI 0450	X302171	790	3	A070UD33TTI450
	A070 URD	33	TTI 0500	X300446			A070UD33TTI500
	A070 URD	33	TTI 0550	Y300447			A070UD33TTI550
	A070 URD	33	TTI 0630	Z300448			A070UD33TTI630
	A070 URD	33	TTI 0700	A300449			A070UD33TTI700
	A070 URD	33	TTI 0800	T300443			A070UD33TTI800
	A070 URD	33	TTI 0900	B300450			A070UD33TTI900
	A070 URD	33	TTI 1000	C300451			A070UD33TTI1000
	A070 URD	33	TTI 1100	D300452			A070UD33TTI1100
	A070 URD	33	TTI 1250**	E300453			A070UD33TTI1250
	A070 URD	33	TTI 1400**	F300454			A070UD33TTI1400
	A065 URD	33	TTI 1500**	F302064			A065UD33TTI1500
	A065 URD	33	TTI 1600**	S301086			A065UD33TTI1600
	A065 URD	33	TTI 1800**	T301087			A065UD33TTI1800
	A060 URD	33	TTI 2000**	V301088			A060UD33TTI2000
	A055 URD	33	TTI 2250**	W301089			A055UD33TTI2250
	A050 URD	33	TTI 2500**	Y300838			A050UD33TTI2500

Rated Voltage as per American standard



Protistor® Square-body Fuses PSC aR sizes 3x - 450V to 700 VAC American Terminals - 30 - 33 End contacts

Size	A	B	C	D	E ^{±1}	d	G ^{±0.1}	P ^{±0.1}
30	40 1-19/32"	46.5 1-27/32"	82 3-7/32"	26 1"	50.6 2"	5/16"-18	9 23/64"	6 15/64"
31	51 2"	56.5 2-7/32"	91 3-37/64"	30 1-3/16"	50.6 2"	5/16"-18	9 23/64"	9 23/64"
32	60 2-3/8"	65.5 2-37/64"	100 3-15/16"	38 ; (42 **) 1-1/2" ; (1-21/32" **)	50.6 2"	3/8"-16	15 19/32"	9 23/64"
33	74.5 2-15/16"	79.5 3-1/8"	114 4-1/2"	46 ; (52 **) 1-13/16" ; (2-1/16" **)	50.6 2"	1/2"-13	15 19/32"	9 23/64"

Note:
dimensions in mm
dimensions in inches

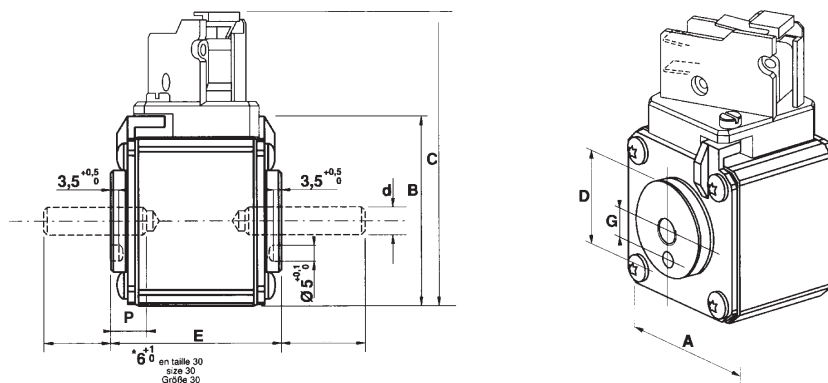

Microswitches are supplied separately see microswitches PSC 3x & 7x section

Protistor® Square-body Fuses PSC aR sizes 3x - 450V to 700 VAC Curves set

Sizes 30 - 31 - 32 - 33

I²t Multiplier coefficient

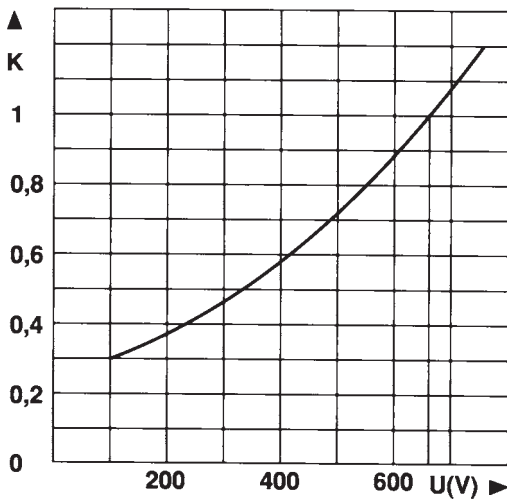

Mean curve indicating variation of total I²t (I²t_t) and total operating time T_t in accordance with working voltage U.

Example:

Fuse 350 A in size 30.
I_p = 10 000 A U = 500 V

At 660 V
I²t_t = 80 000 A²s T_t = 6 ms

At 500 V
I²t_t = 80 000 × 0.72 = 57 600 A²s
T_t = 6 × 0.72 = 4.3 ms

Dissipated power

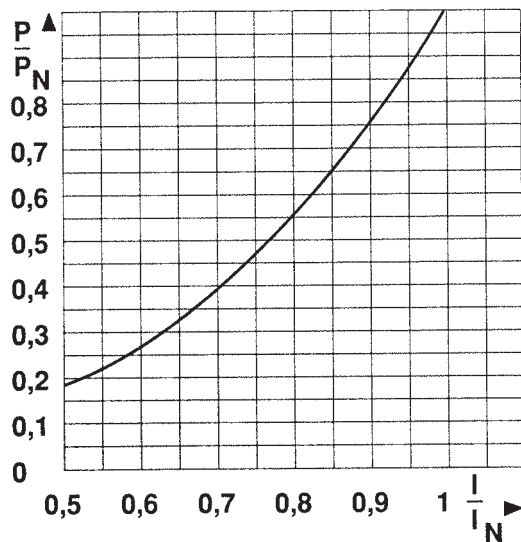

Curve enabling calculation of dissipated power P by a fuse rated I_N, as a function of the RMS current I, in multiples of I_N, in a steady state.

Arc voltage

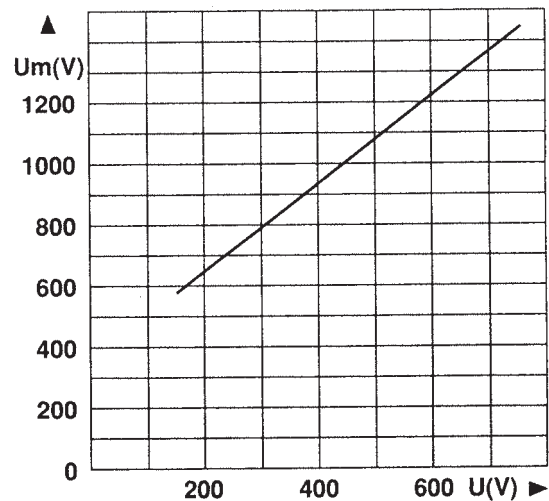

Curve indicating peak arc voltage U_m which may appear across fuse terminals as function of working voltage U at cos φ = 0.15



Protistor® Square-body Fuses PSC aR sizes 3x - 450V to 700 VAC Curves set

Size 30

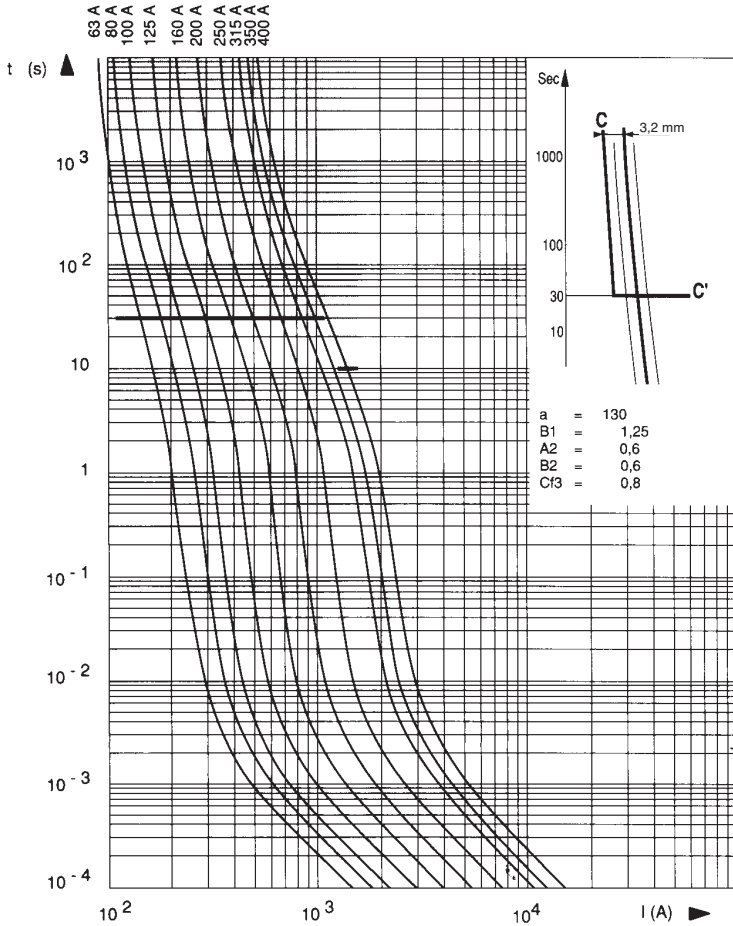

↓ Cut-off characteristics

Below, right: Curves indicating for each rated-current the peak value I_C that the current may reach as a function of the prospective fault current I_p .

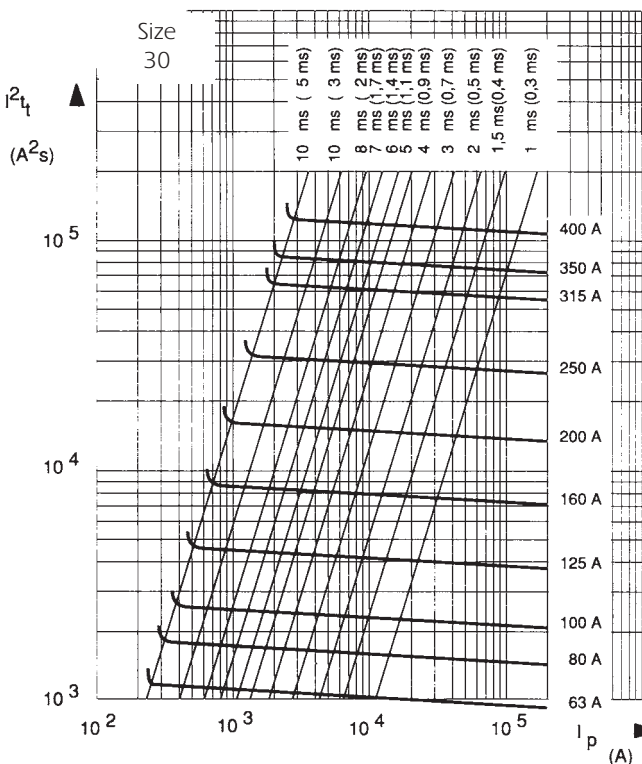
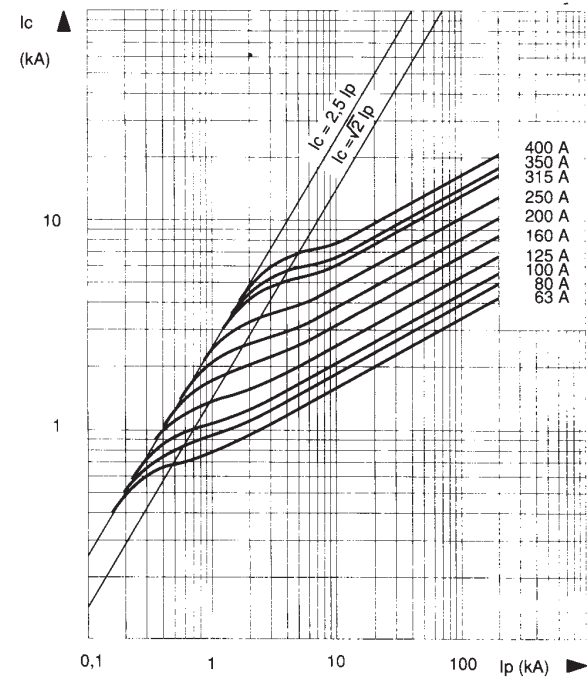

↑ Time-current characteristics

Above, left: Curves indicating pre-arcing time for each rated current as a function of RMS value of pre-arcing current I .

- Tolerances on this current $\pm 8\%$.
- Beyond 30 sec or 10 sec, small overloads must be eliminated by another device.
- Curve CC' represents the maximum times taken by the associated device to clear small overloads; only its horizontal line is represented. Its oblique line must be plotted according to sketch, top right corner.
- The intersection of the fuse and CC' curves indicates the minimum breaking current I_{pm} of the fuse.

← Maximum values of total operating I^2t and total operating times

Left: Horizontal curves indicating the maximum values of total operating I^2t (I^2t_t) as function of the prospective current I_p at 660 V, $\cos \varphi = 0.15$. The oblique lines indicate the corresponding total operating time T_T , with pre-arcing time in brackets.

Protistor® Square-body Fuses PSC aR sizes 3x - 450V to 700 VAC Curves set

Size 31

↓ Cut-off characteristics

Below, right: Curves indicating for each rated current the peak value I_C that the current may reach as a function of the prospective fault current I_P .

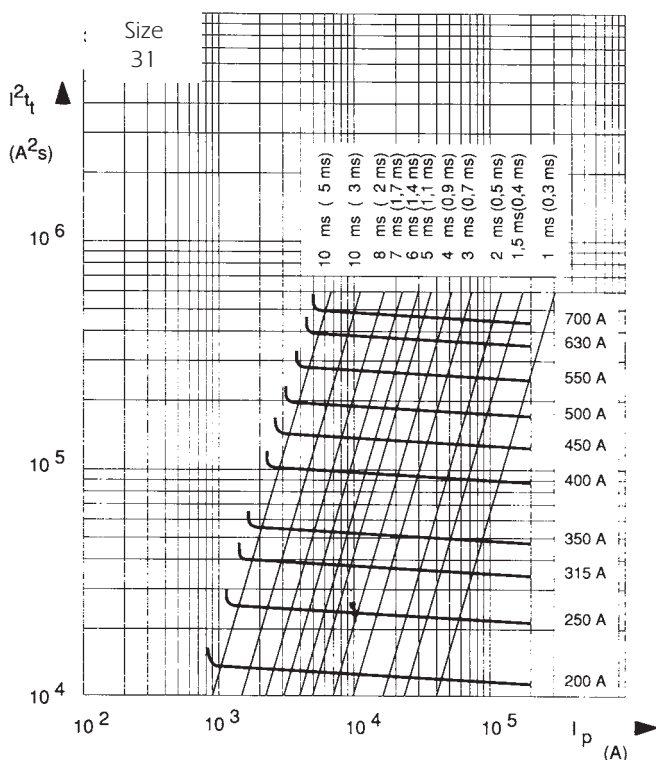
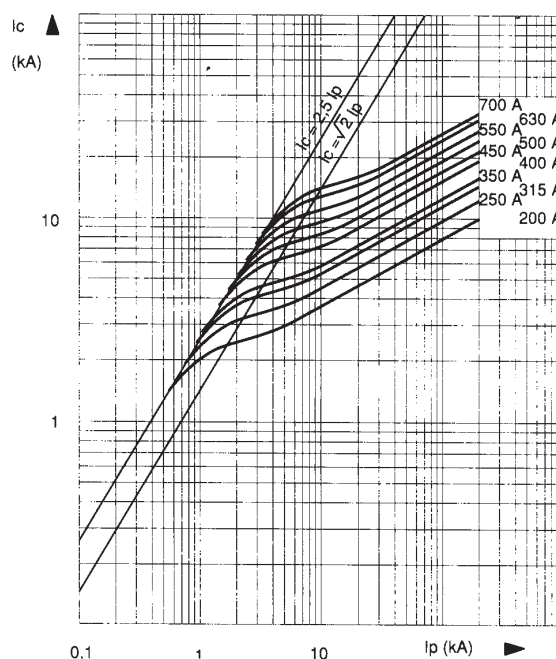
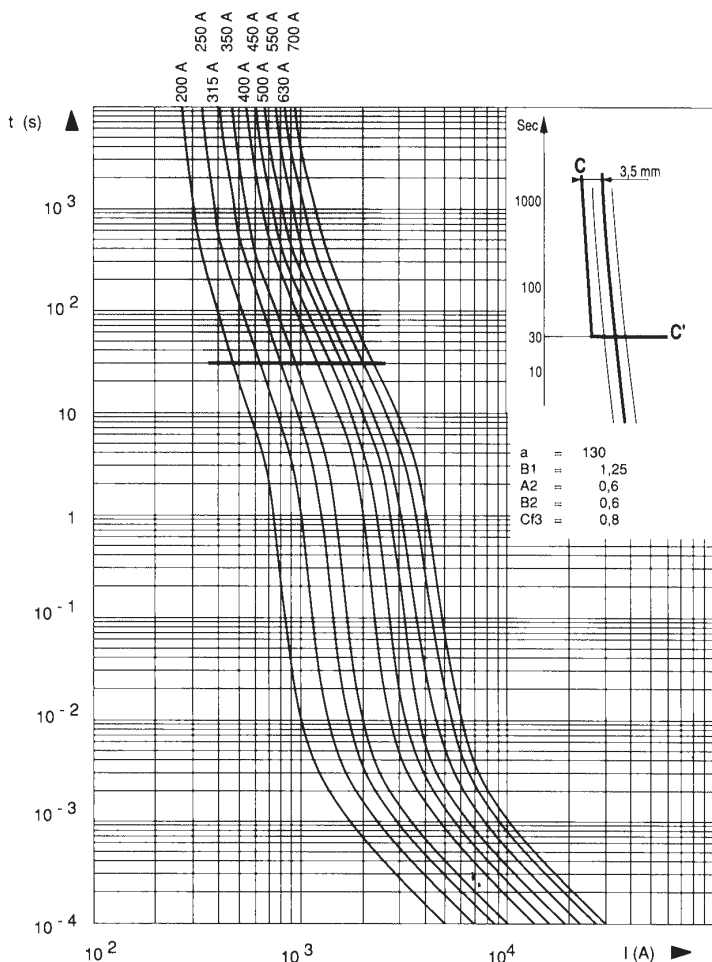

↑ Time-current characteristics

Above, left: Curves indicating pre-arcing time for each rated current as a function of RMS value of pre-arcing current I .

- Tolerances on this current $\pm 8\%$.
- Beyond 30 sec or 10 sec, small overloads must be eliminated by another device.
- Curve CC' represents the maximum times taken by the associated device to clear small overloads; only its horizontal line is represented. Its oblique line must be plotted according to sketch, top right corner.
- The intersection of the fuse and CC' curves indicates the minimum breaking current I_{pm} of the fuse.

← Maximum values of total operating I^2t and total operating times

Left: Horizontal curves indicating the maximum values of total operating I^2t (I^2t_t) as function of the prospective current I_P at 660 V, $\cos \varphi = 0.15$. The oblique lines indicate the corresponding total operating time T_T , with pre-arcing time in brackets.



Protistor® Square-body Fuses PSC aR sizes 3x - 450V to 700 VAC Curves set

Size 32

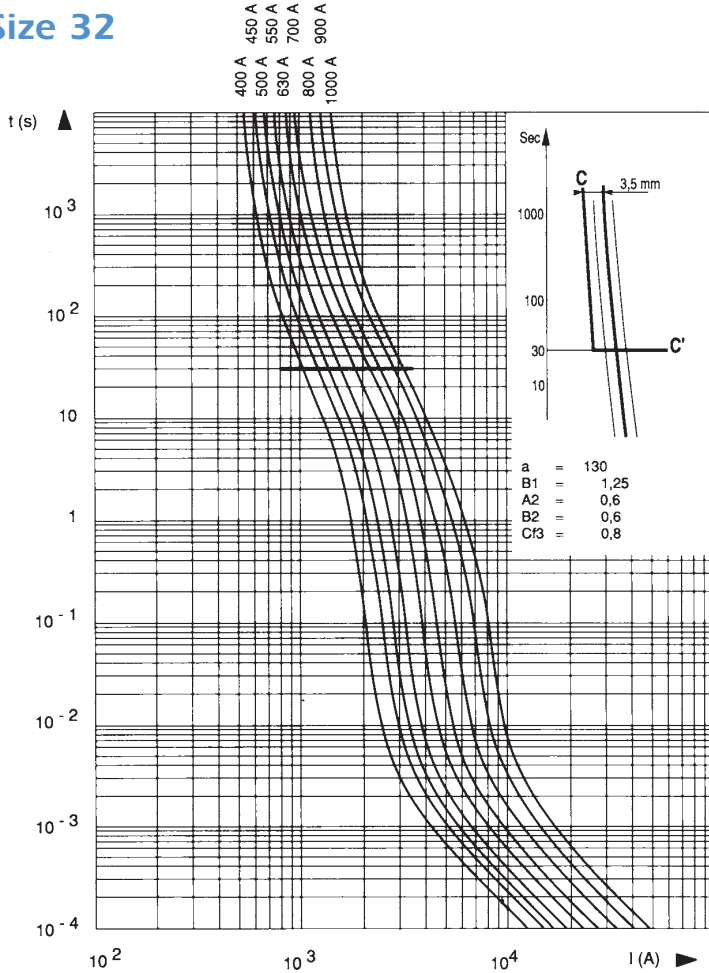

↓ Cut-off characteristics

Below, right: Curves indicating for each rated-current the peak value I_C that the current may reach as a function of the prospective fault current I_p .

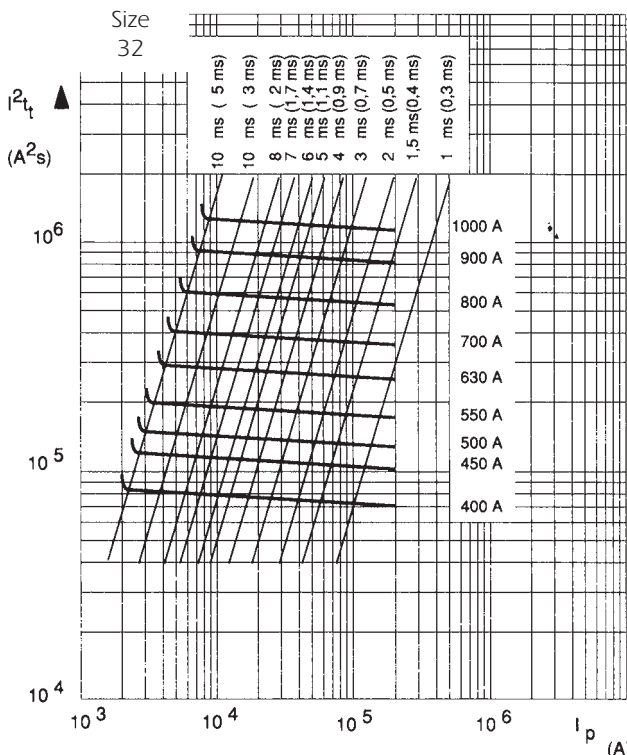
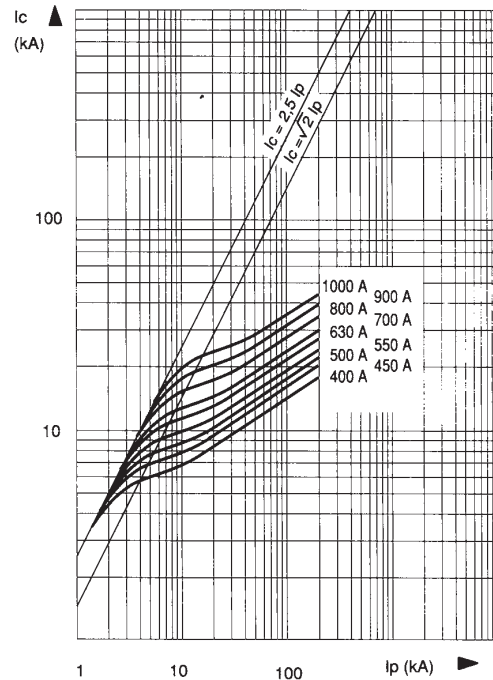

↑ Time-current characteristics

Above, left: Curves indicating pre-arcing time for each rated current as a function of RMS value of pre-arcing current I .

- Tolerances on this current $\pm 8\%$.
- Beyond 30 sec or 10 sec, small overloads must be eliminated by another device.
- Curve CC' represents the maximum times taken by the associated device to clear small overloads; only its horizontal line is represented. Its oblique line must be plotted according to sketch, top right corner.
- The intersection of the fuse and CC' curves indicates the minimum breaking current I_{pm} of the fuse.

← Maximum values of total operating I^2t and total operating times

Left: Horizontal curves indicating the maximum values of total operating I^2t (I^2t_t) as function of the prospective current I_p at 660 V, $\cos \varphi = 0.15$. The oblique lines indicate the corresponding total operating time T_t , with pre-arcing time in brackets.

Protistor® Square-body Fuses PSC aR sizes 3x - 450V to 700 VAC Curves set

Size 33

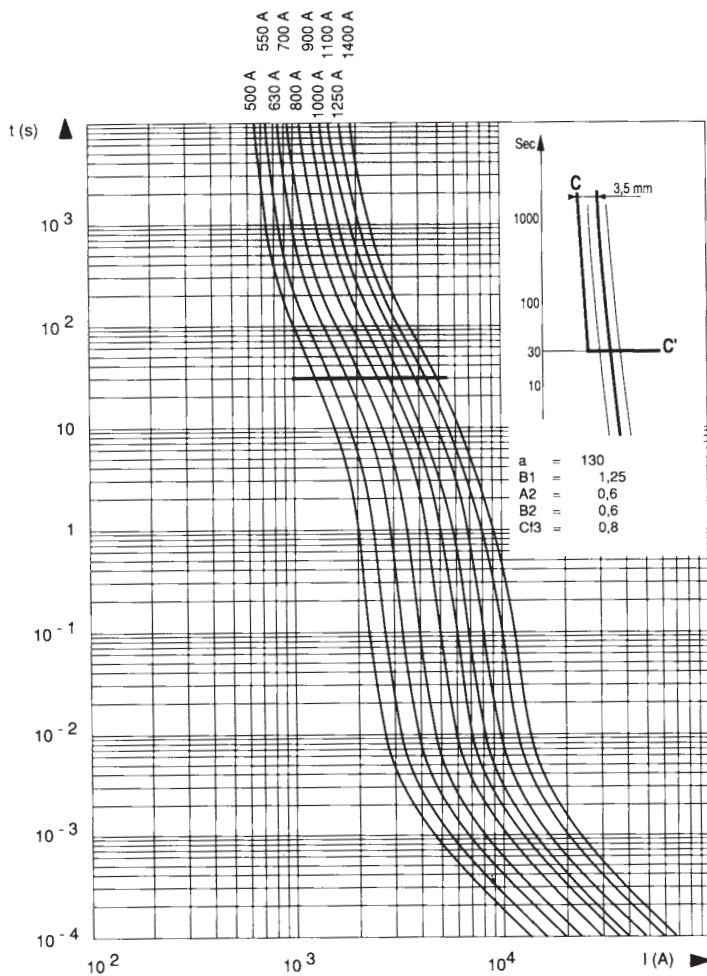

↓ Cut-off characteristics

Below, right: Curves indicating for each rated current the peak value I_C that the current may reach as a function of the prospective fault current I_p .

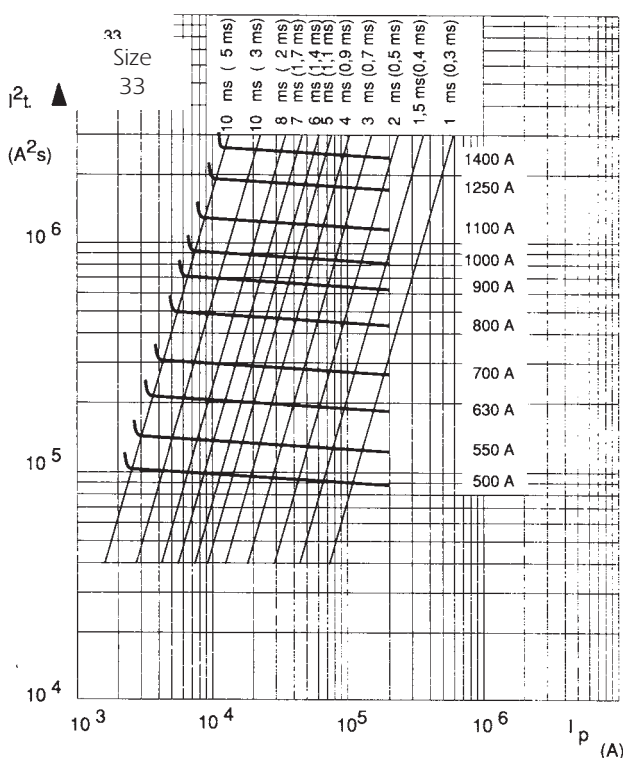
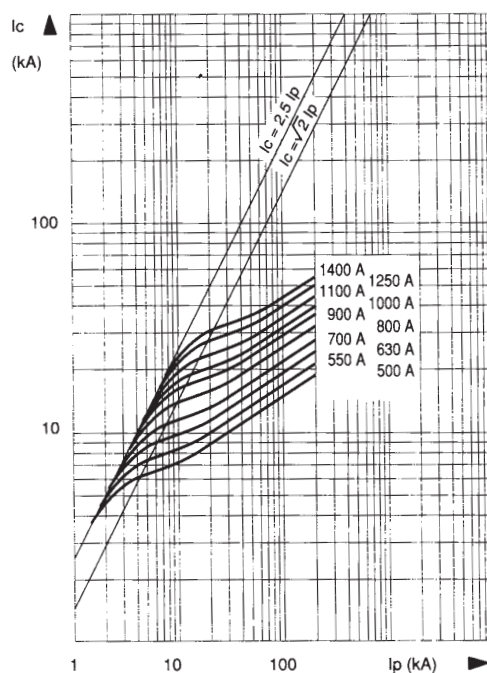

↑ Time-current characteristics

Above, left: Curves indicating pre-arcing time for each rated current as a function of RMS value of pre-arcing current I .

- Tolerances on this current $\pm 8\%$.
- Beyond 30 sec or 10 sec, small overloads must be eliminated by another device.
- Curve CC' represents the maximum times taken by the associated device to clear small overloads; only its horizontal line is represented. Its oblique line must be plotted according to sketch, top right corner.
- The intersection of the fuse and CC' curves indicates the minimum breaking current I_{pm} of the fuse.

← Maximum values of total operating I^2t and total operating times

Left: Horizontal curves indicating the maximum values of total operating I^2t (I^2t_t) as function of the prospective current I_p at 660 V, $\cos \varphi = 0.15$. The oblique lines indicate the corresponding total operating time T_t , with pre-arcing time in brackets.



Protistor® Square-body Fuses PSC aR sizes 3x - 450V to 700 VAC Curves set

Sizes 2x32

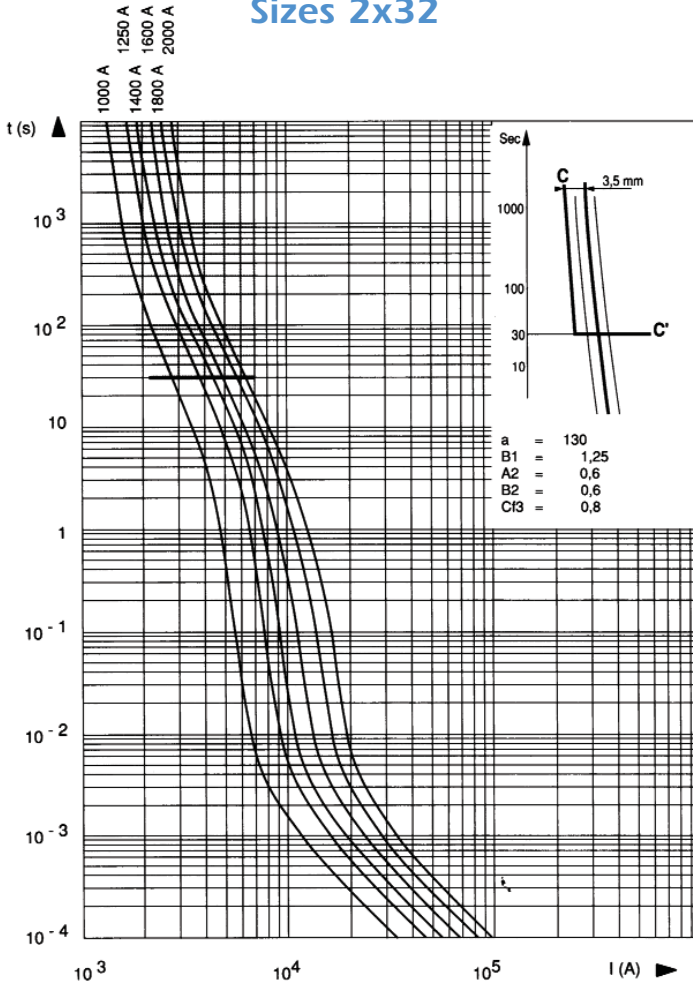

↓ Cut-off characteristics

Below, right: Curves indicating for each rated-current the peak value I_C that the current may reach as a function of the prospective fault current I_p .

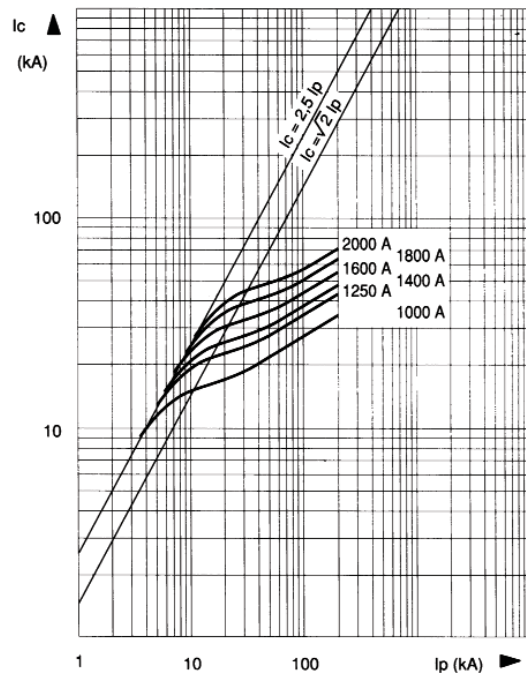

↑ Time-current characteristics

Above, left: Curves indicating pre-arcing time for each rated current as a function of RMS value of pre-arcing current I .

- Tolerances on this current $\pm 8\%$.
- Beyond 30 sec or 10 sec, small overloads must be eliminated by another device.
- Curve CC' represents the maximum times taken by the associated device to clear small overloads; only its horizontal line is represented. Its oblique line must be plotted according to sketch, top right corner.
- The intersection of the fuse and CC' curves indicates the minimum breaking current I_{pm} of the fuse.

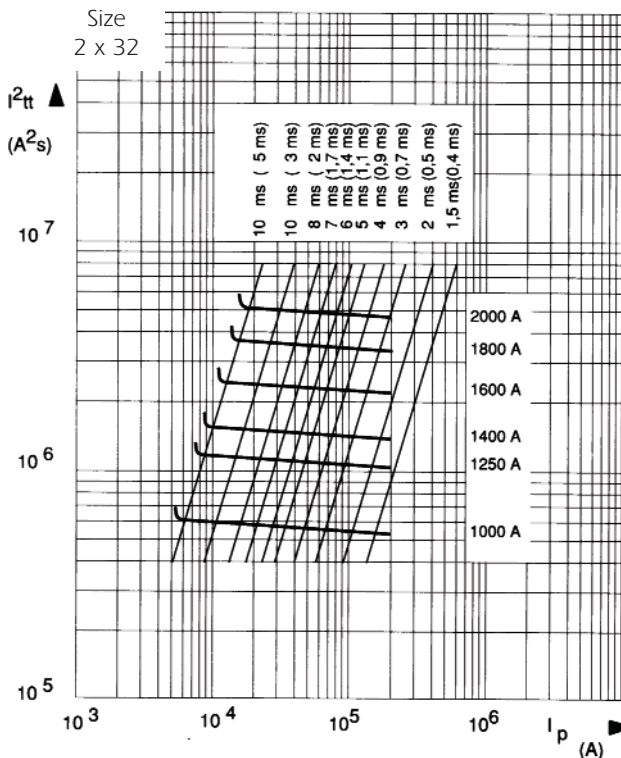

← Maximum values of total operating I^2t and total operating times

Left: Horizontal curves indicating the maximum values of total operating I^2t (I^2t_t) as function of the prospective current I_p at 660 V, $\cos \varphi = 0.15$. The oblique lines indicate the corresponding total operating time T_t , with pre-arcing time in brackets.

Protistor® Square-body Fuses PSC aR sizes 3x - 450V to 700 VAC Curves set

Size 2x33

↓ Cut-off characteristics

Below, right: Curves indicating for each rated current the peak value I_C that the current may reach as a function of the prospective fault current I_p .

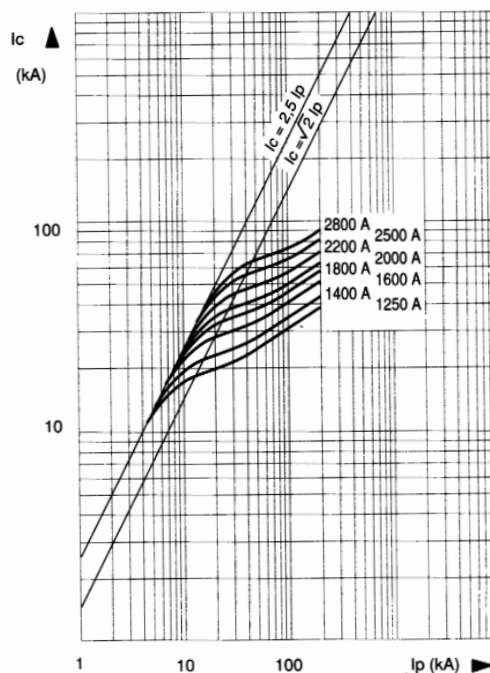
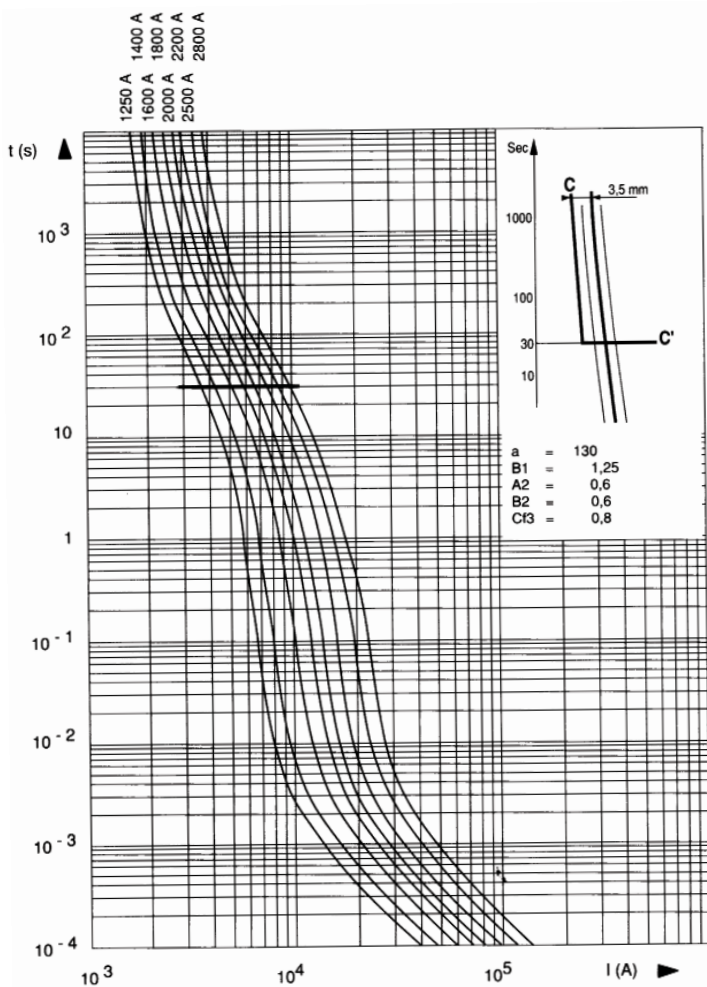

↑ Time-current characteristics

Above, left: Curves indicating pre-arcing time for each rated current as a function of RMS value of pre-arcing current I .

- Tolerances on this current $\pm 8\%$.
- Beyond 30 sec or 10 sec, small overloads must be eliminated by another device.
- Curve CC' represents the maximum times taken by the associated device to clear small overloads; only its horizontal line is represented. Its oblique line must be plotted according to sketch, top right corner.
- The intersection of the fuse and CC' curves indicates the minimum breaking current I_{pm} of the fuse.

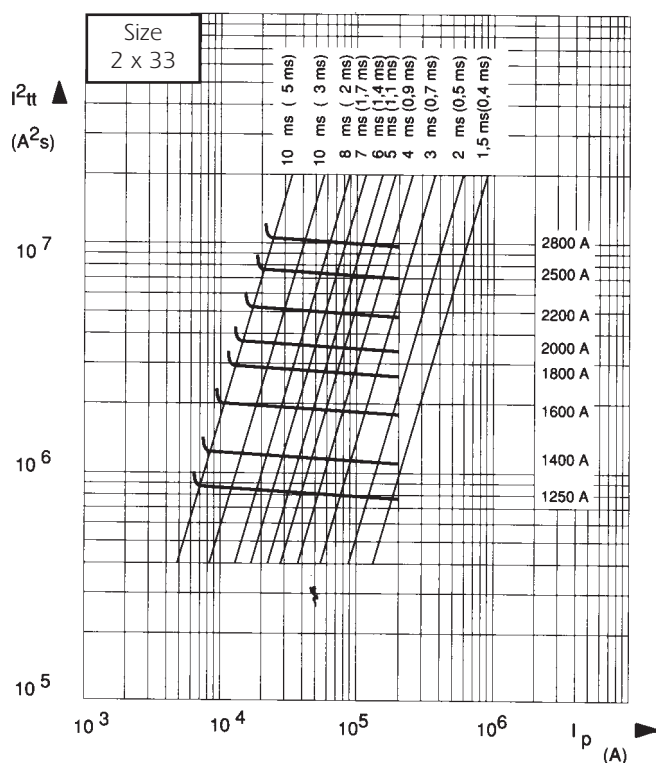

← Maximum values of total operating I^2t and total operating times

Left: Horizontal curves indicating the maximum values of total operating I^2t (I^2t_t) as function of the prospective current I_p at 660 V, $\cos \varphi = 0.15$. The oblique lines indicate the corresponding total operating time T_t , with pre-arcing time in brackets.



Protistor® Square-body Fuses PSC aR sizes 3x - 450V to 700 VAC Curves set

Sizes 30 - 31 - 32 - 33

DC working voltage possibilities

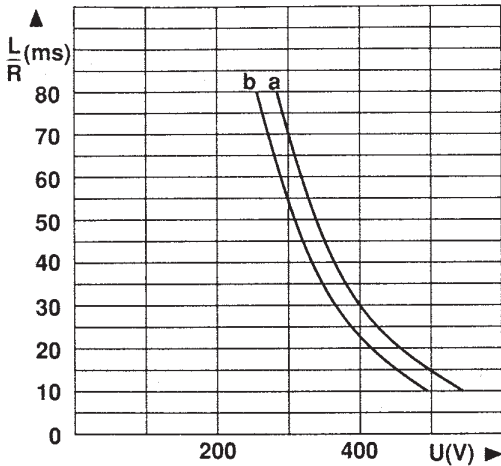

Rated current In (A)	Curves (*) and Ipm (†) corresponding to the rating					
	30 * Ipm (A)	31 * Ipm (A)	32 * Ipm (A)	33 * Ipm (A)	2 x 32 * Ipm (A)	2 x 33 * Ipm (A)
63	a 230					
80	a 300					
100	a 360					
125	a 460					
160	a 650					
200	a 880	a 850				
250	a 1300	a 1150				
315	a 1700	a 1450				
350	a 1900	a 1600				
400	a 2300	a 2200	a 2000			
450		a 2500	a 2300			
500		a 3000	a 2600	a 2300		
550		a 3400	a 3150	a 2500		
630		a 5000	a 3700	a 3250		
700		a 5600	a 4300	a 3900		
800			a 5300	a 4800		
900			a 7800	a 5600		
1000			b 9000	a 6600	a 5200	
1100				a 7700		
1250				b 11000	a 7400	a 6500
1400				b 12500	a 8600	a 7800
1600					a 10600	a 9600
1800					a 15600	a 11200
2000					b 18000	a 13200
2200						a 15400
2500						b 22000
2800						b 25000

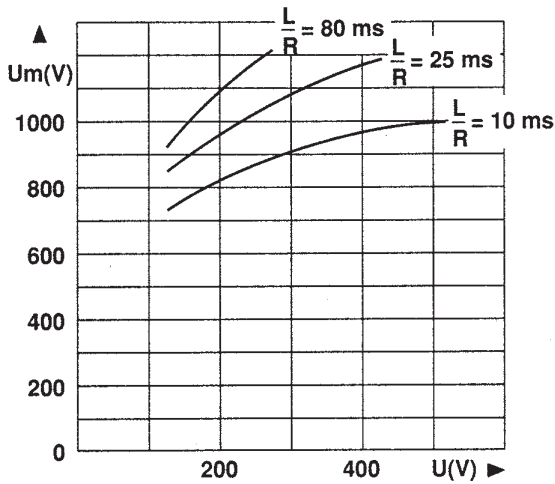

Top: Curves indicating the maximum time constant L/R of the fault path as a function of the DC voltage U for the rated currents in the sizes indicated in the table.

I_{pm} (†) values indicate the minimum breaking current in Amperes (A).

Remark:

When the fault current di/dt is very large, this condition can be exceeded. This is the case for faults occurring in voltage commutated inverters.

Below: Curves indicating peak arc voltage U_m which may appear across fuse terminals as a function of the DC working voltage U , for various time constant L/R of fault path.

Protistor® Square-body Fuses PSC aR sizes 3x - 450V to 700 VAC Microswitches PSC 3x & 7x

- MICROSWITCH SYSTEMS ADAPTED TO THE FOLLOWING FERRAZ SHAWMUT FUSES ONLY:
- PSC sizes 30, 31, 32, 33, 2x32, 2x33 / 70, 71, 72, 73, 272, 273 except plain blades
- PSC LR sizes 33, 233, 73, 273
- PERMANENT INDICATION OF FUSE STATE: CONDUCTIVE
BLOWN
- MANUAL RESETTING
- STANDARD AND LOW ELECTRICAL LEVEL WITH DIFFERENT INSULATION LEVELS
- BS TYPE FOR USE IN CORROSIVE ATMOSPHERE
- MS 3V 1-5 UR AND MS 7V 1-5 UR TYPE UL ARE RECOGNIZED



MS 7V 1-5

Main Characteristics

Code	AC Insulation voltage rating (***)	Positive operating voltage/current	Current rating	Current	Breaking Capacity						AC voltage withstand test (*)	Impulse voltage test Uimp1.2/50 µs (**)	Fire class according to UL 94
					Non inductive circuit			Inductive circuit : L/R = 25ms					
					30V	110V	250V	30V	110V	250V			
MS 3V 1-5	1000 V	20 V 50 mA	10 A	50/60 Hz	10 A	10 A	10 A	10 A	10 A	10 A	8,5 kV	14 kV	H.B
MS 3V 1-5 UR				DC	8 A	0,4 A	0,2 A	4 A	0,2 A	0,1 A			
MS 7V 1-5	1500V	10 V 10 mA	3 A	50/60 Hz	3 A	3 A	3 A	2 A	1 A	1 A	8,5 kV	14 kV	
MS 7V 1-5 UR				DC	3 A	0,5 A	0,25 A	3 A	0,2 A	0,1 A			
MS 3V 1-5 BS	1000 V	10 V 10 mA	3 A	50/60 Hz	3 A	3 A	3 A	2 A	1 A	1 A	8,5 kV	14 kV	
MS 3V 1-9 BS				DC	3 A	0,5 A	0,25 A	3 A	0,2 A	0,1 A			
MS 7V 1-5 BS	1500V	10 V 10 mA	3 A	50/60 Hz	3 A	3 A	3 A	2 A	1 A	1 A	8,5 kV	14 kV	
MS 7V 1-9 BS				DC	3 A	0,5 A	-	2 A	0,2 A	-			
MS 3V 1-5 ET	1000V	10 V	3 A	50/60 Hz	3 A	3 A	3 A	2 A	1 A	1 A	8,5 kV	14 kV	
MS 7V 1-5 ET	1500V	10 mA	3 A	DC	3 A	0,5 A	-	2 A	0,2 A	-	12 kV	20 kV	

* Between power circuit and microswitch terminals as per IEC 60 and 694 and NFC 64010 (50/60 Hz 1 min duration in dry air)

** Between power circuit and microswitch terminals Uimp: impulse voltage as per IEC 60947-1

*** Between power circuit and microswitch terminals

Warning: microswitch systems exclusively designed for FERRAZ SHAWMUT.
PSC Fuses fitted a patented trip-indicator, saving use of EDV



Protistor® Square-body Fuses PSC aR sizes 3x - 450V to 700 VAC Microswitches for PSC 3x & 7x

Indication systems for PSC Fuse sizes 30 to 73 MS 3V...

These patented indication systems are exclusively hand resettable.

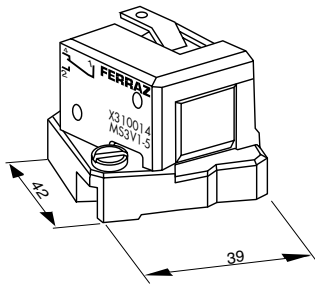

(fig. 1)

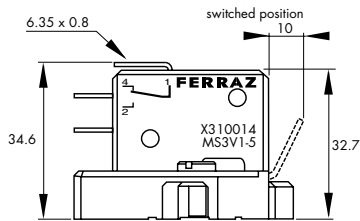

Fuse size	Designation	Ref. Number	Indication style	Weight (g)	Pack.	Catalog Number
30, 31 32, 33	MS 3V 1-5 (fig.1)	X310014	Standard NO-NC	34	3 pieces	MS3 V1-5
	MS 3V 1-5 UR	Y310038				MS3 V1-5UR
	MS 3V 1-5 BS (3)	K310013	Low level NO-NC	34	3 pieces	MS3-V1-5BS
	MS 3V 1-9 BS (4)	P310011	Double pole Low level	44	3 pieces	MS3V1-9BS
	MS 3V 1-5 ET (fig.2)	S310009	Low level NO-NC IP 50 (9)	34	3 pieces	MS3V1-5 ETANCHE

(3) Same as fig.1

(4) Same dimensions as figure 1 but with 2 microswitches side by side

(9) Watertightness class

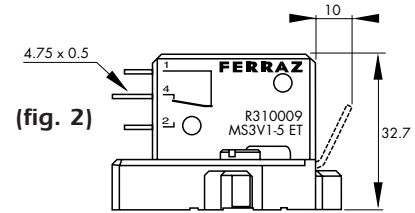

(fig. 2)

MS 7V...

Fuse size	Designation	Ref. Number	Indication style	Weight (g)	Pack.	Catalog Number
70, 71 72, 73	MS 7V 1-5 (fig.5)	J310002	Standard NO-NC	45	3 pieces	MS7 V1-5
	MS 7V 1-5 UR	Z310039				MS7 V1-5UR
	MS 7V 1-5 BS (3)	K310003	Low level NO-NC	45	3 pieces	MS7-V1-5BS
	MS 7V 1-9 BS (4)	P310007	Double pole Low level	55	3 pieces	MS7V1-9BS
	MS 7V 1-5 ET (fig.6)	S310010	Low level NO-NC IP 50 (9)	55	3 pieces	MS7V1-5 ETANCHE

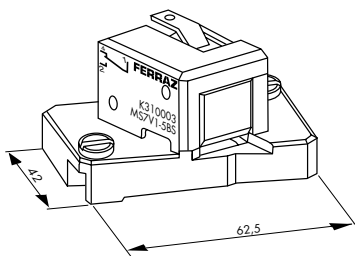

(fig. 5)

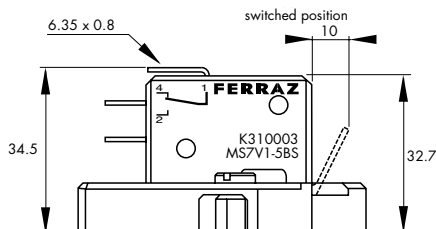

(7) Same as fig. 5

(8) Same dimensions as figure 5 but with 2 microswitches side by side

(9) Watertightness class

Warning: Microswitch systems exclusively designed for FERRAZ SHAWMUT PSC fuses fitted with a patented trip-indicator, saving use of EDV.

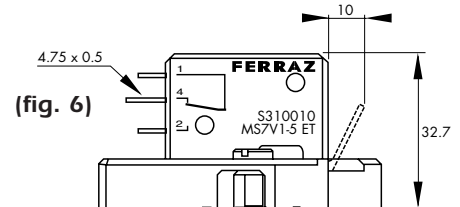

(fig. 6)